



## South Australia Class 3 23m Truck and Dog Trailer Mass and Dimension Exemption Notice 2020 (No.1)

### 1 Purpose

The purpose of this Notice is to exempt Class 3 heavy vehicle 23m long truck and dog trailer combinations from stated mass and dimension limits in Schedule 1 and 6 of the *Heavy Vehicle (Mass, Dimension and Loading) National Regulation (the Regulation)*.

This Notice revokes and replaces the *South Australia Class 3 Heavy Vehicle 23m Truck and Dog Trailer Mass and Dimension Exemption Notice 2017*.

*Note- This Notice replaces Schedule 3 of the South Australia Consolidated National Heavy Vehicle Mass and Dimension Notice 2014. It includes new provisions for three axle truck and four axle dog trailer combinations that were not available in the original notice.*

*This Notice removes the maintenance conditions, and incorporates all amendments to prior versions. No other exemptions or conditions of this Notice are changed.*

### 2 Authorising Provision

This Notice is made under section 117 of the Heavy Vehicle National Law (HVNL).

### 3 Title

This Notice may be cited as the *South Australia Class 3 Heavy Vehicle 23m Truck and Dog Trailer Mass and Dimension Exemption Notice 2020*.

### 4 Commencement

This Notice commences on 1 August 2020.

### 5 Expiry

This Notice expires on 4 September 2022.

### 6 Definitions

In this Notice—

**23m Truck and Dog Trailer** means a combination consisting of a truck with 3 axles towing a dog trailer with 3, 4 or 5 axles.

## **7 Application**

- (1) This Notice applies to 23m Truck and Dog Trailers operating in South Australia.
- (2) This Notice applies to a 23m Truck and Dog Trailer combination where:-
  - a) the truck has a single steer axle and a dual-drive tandem axle group; and,
  - b) the three axle dog trailer has a single axle at the front and a tandem axle group at the rear; and
  - c) the four axle dog has a tandem group at the front and a tandem group at the rear; and
  - d) the five axle dog trailer has a tandem axle group at the front and a tri-axle group at the rear.

## **8 Exemption from prescribed mass and dimension requirements**

- (1) This Notice exempts 23m Truck and Dog Trailer combinations from the—
  - a) dimension limit specified in Section 3(1)(a) of Schedule 6 of Regulation; and the
  - b) mass limits specified in Section 2(1)(a)(iv) and 2(4) of Schedule 1 of the Regulation.
- (2) The exemptions in this section only apply to the extent of the conditional mass and dimension limits set out in section 9 of this Notice, and when other relevant conditions in the Notice are met.

## **9 Conditions**

- (1) The mass of the 23m Truck and Dog Trailer operating under the general mass limits must not be more than—
  - a) in the case of a combination consisting of a truck towing a 3 axle dog trailer – 48t;
  - b) in the case of a combination consisting of a truck towing a 4 axle dog trailer- 55.5t;
  - c) in the case of a combination consisting of a truck towing a 5 axle dog trailer– 59t.
- (2) The mass of the 23m Truck and Dog Trailer operating under the general mass limits and with a complying steer axle must not be more than;
  - a) In the case of a combination consisting of a truck towing a 3 axle dog trailer– 48.5t;
  - b) In the case of a combination consisting of a truck towing a 4 axle dog trailer- 56t;
  - c) In the case of a combination consisting of a truck towing a 5 axle dog trailer– 59.5t.
- (3) The 23m Truck and Dog Trailer combination must not be longer than 23m.

(4) The 23m Truck and Dog Trailer combination must comply with the minimum axle spacing requirements as per the configurations for each combination illustrated in the figures below:

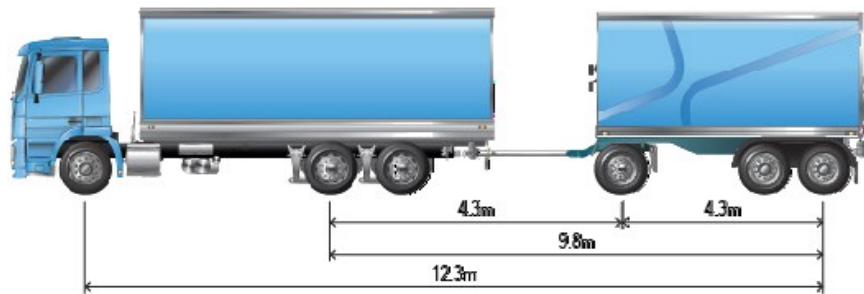

**Figure 1 - Truck and three axle dog trailer minimum axle spacing**

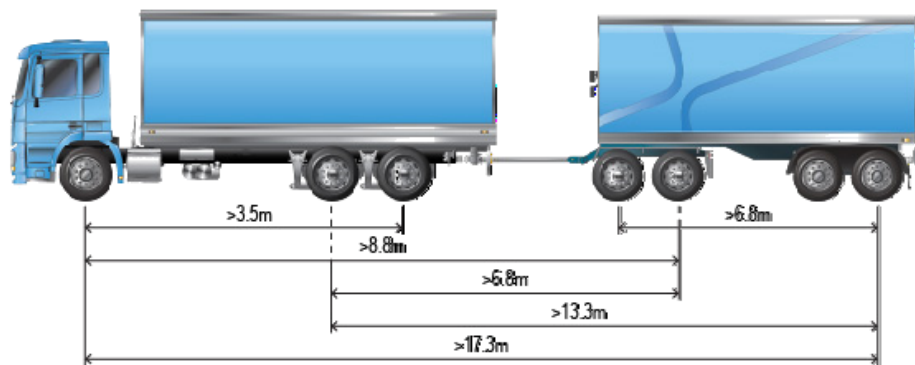

**Figure 2 - Truck and four axle dog trailer minimum axle spacing**

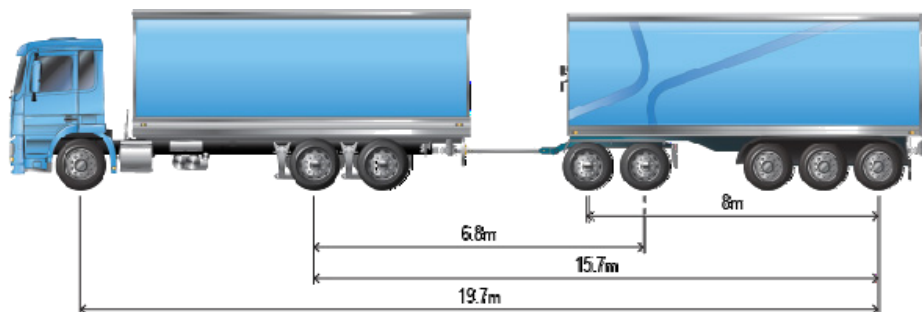

**Figure 3 - Truck and five axle dog trailer minimum axle spacing**

- (5) The 23m Truck and Dog Trailer combination must not exceed a speed of 80km/h or any posted speed limit whichever is the lesser.
- (6) A 23m Truck and Dog Trailer operating under this Notice is not permitted to operate under the Concessional Mass Limits or Higher Mass Limits.
- (7) If the 23m Truck and Dog trailer combination exceeds a length of 22m, a Long Vehicle sign must be displayed at the rear of the vehicle in accordance with clauses 5(3) and 6 of the Heavy Vehicle (Vehicle Standards) National Regulation.

## 10 Condition - Stated Areas and Routes

(1) 23m Truck and Dog Trailer combinations operating under this notice may use the following stated routes:

- a) Routes set out in the '23m Truck and Dog Network' published by the South Australia Department of Planning Transport and Infrastructure (DPTI); and
- b) Routes set out in the South Australia B-Double Commodity routes Network' published by DPTI when:
  - i. a 23m Truck and Dog Trailer combination is carrying a commodity listed on the DPTI RAVNet B-double commodity routes; in
  - ii. a Local Government Road Manager area listed in the South Australia 23m Truck and Dog Trailer Commodity Network List.

*Note: Commodity routes on the DPTI RAVnet are normally limited to B-doubles or Road Trains. However, this notice grants access to the B-double Commodity Networks for 23m Truck and Dog Trailers when carrying the specified commodity (eg: a 23m Truck and Dog Trailer carrying grain may use the B-double Grain Commodity Route).*

*Note: RAVnet Network maps are available at the DPTI website*

Peter Caprioli  
*Executive Director Access*  
**National Heavy Vehicle Regulator**