



Vehicle Standard (Australian Design Rule 4/03 – Seatbelts) 2005

I, JAMES ERIC LLOYD, Minister for Local Government, Territories and Roads, determine this vehicle standard under subsection 7 (1) of the *Motor Vehicle Standards Act 1989*.

Dated 21st November 2005

[SIGNED]

James Eric Lloyd
Minister for Local Government, Territories and Roads

CONTENTS

1.	LEGISLATIVE PROVISIONS	3
1.1.	NAME OF STANDARD.....	3
1.2.	COMMENCEMENT	3
1.3.	REPEAL	3
2.	SCOPE	3
3.	APPLICABILITY AND IMPLIMENTATION.....	3
4.	DEFINITIONS	5
5.	REQUIREMENTS.....	5
6.	ADJUSTMENT REQUIREMENTS.....	8
7.	BUCKLE REQUIREMENTS	9
8.	GENERAL REQUIREMENTS FOR SEATBELT COMPONENTS	11
9.	RETRACTORS (OTHER THAN 'TYPE 4N RETRACTORS')	13
10.	DYNAMIC TEST REQUIREMENTS	15
11.	RETRACTOR DURABILITY TEST	16
12.	DYNAMIC TESTING PROCEDURE.....	16
13.	TEST DUMMY REQUIREMENTS	16
14.	DUMMY CALIBRATION	17
15.	TEST RIG CALIBRATION	17
16.	COMPONENT BOUNDARY LOCATION.....	17
17.	DETAILED REQUIREMENTS FOR VEHICLE CATEGORIES MD3, MD4, ME, NB2 AND NC ONLY	18
18.	CORROSION CONDITIONING PROCEDURE FOR SEATBELT ASSEMBLIES FITTED IN ACCORDANCE WITH CLAUSE 17	19
19.	ADJUSTMENT REQUIREMENTS FOR VEHICLE CATEGORIES MD3, MD4, ME, NB2 AND NC ONLY	19
20.	ALTERNATIVE STANDARDS	19
	APPENDIX A.....	24

1. LEGISLATIVE PROVISIONS

1.1. NAME OF STANDARD

- 1.1.1. This Standard is the Vehicle Standard (Australian Design Rule 4/03 – Seatbelts) 2005.
- 1.1.2. This Standard may also be cited as Australian Design Rule 4/03 — Seatbelts.

1.2. COMMENCEMENT

- 1.2.1. This Standard commences on the day after it is registered.

1.3. REPEAL

- 1.3.1. This Standard repeals each vehicle standard with the name Australian Design Rule 4/03 — Seatbelts that is:
 - (a) made under section 7 of the Motor Vehicles Standard Act 1989; and
 - (b) in force at the commencement of this Standard.
- 1.3.2. This Standard also repeals each instrument made under section 7 of the Motor Vehicles Standard Act 1989 that creates a vehicle standard with the name Australian Design Rule 4/03 — Seatbelts, if there are no other vehicle standards created by that instrument, or amendments to vehicle standards made by that instrument, that are still in force at the commencement of this Standard.

2. SCOPE

The function of this Australian Design Rule is to specify requirements for seatbelts to restrain vehicle occupants under impact conditions, to facilitate fastening and correct adjustment, to assist the driver to remain in the driver's 'Seat' and thus maintain control of the vehicle in an emergency situation, and to provide protection against ejection in an accident situation.

3. APPLICABILITY AND IMPLEMENTATION

- 3.1. Applicability Summary
 - 3.1.1. Subject to clause 3.1.2, this ADR applies to the design and construction of vehicles as set out in the table below.
 - 3.1.2. Where ECE 16/04 was used as the Alternative Standard, vehicles meeting the requirements of any of the Acceptable Prior Rules shown below in the Applicability Table for a particular category are deemed to comply with this rule.
 - 3.1.3. For omnibuses complying with ADR 68/.. only the driver's seatbelt is required to comply with clauses 17 to 19 of this rule.

3.2. Applicability Table

Vehicle Category	ADR Category Code	UNECE Category Code	Manufactured on or After	Acceptable Prior Rules
Moped 2 wheels	LA	L1		
Moped 3 wheels	LB	L2	N/A	
Motor cycle	LC	L3	N/A	
Motor cycle and sidecar	LD	L4	N/A	
Motor tricycle	LE	L5		
	LEM		N/A	
	LEP		1 Jan 2000	/01, /02
	LEG		1 Jan 2000	/01, /02
Passenger car	MA	M1	1 Jan 2000	/00, /01, /02
Forward-control passenger vehicle	MB	M1	1 Jan 2000	/00, /01, /02
Off-road passenger vehicle	MC	M1	1 Jan 2000	/02
Light omnibus	MD	M2		
up to 3.5 tonnes 'GVM' and up to 12 seats	MD1		1 Jan 2000	/00, /01, /02
up to 3.5 tonnes 'GVM' and more than 12 seats	MD2		1 Jan 2000	Nil
over 3.5 tonnes and up to 4.5 tonnes 'GVM'	MD3		1 Jan 2000	/01, /02
over 4.5 tonnes and up to 5 tonnes 'GVM'	MD4		1 Jan 2000	/01, /02
Heavy omnibus	ME	M3	1 Jan 2000	/01, /02
Light goods vehicle	NA	N1	1 Jan 2000	/02
Medium goods vehicle	NB	N2		
over 3.5 tonnes up to 4.5 tonnes 'GVM'	NB1		1 Jan 2000	/00, /01, /02
over 4.5 tonnes up to 12 tonnes 'GVM'	NB2		1 Jan 2000	/01, /02
Heavy goods vehicle	NC	N3	1 Jan 2000	/01, /02
Very light trailer	TA	O1	N/A	
Light trailer	TB	O2	N/A	
Medium trailer	TC	O3	N/A	
Heavy trailer	TD	O4	N/A	

4. DEFINITIONS

- 4.1. Refer to Vehicle Standard (Australian Design Rule Definitions and Vehicle Categories) 2005.

5. REQUIREMENTS

5.1. General

- 5.1.1. Vehicle categories LEP, MA, MB, MC, NA, MD1 and MD2 must comply with clauses 5.2 to 16.
- 5.1.2. Vehicle categories LEG and NB1 must comply with either:
- 5.1.2.1. clauses 5.2, 5.3.1 (excluding 5.3.1.3 and 5.3.1.4) and 5.4 to 16 (excluding 10.2 and 10.3, for omnibuses); or
- 5.1.2.2. clause 5.1.1.
- 5.1.3. Vehicles categories MD3, MD4, ME, NB2 and NC must comply with either:
- 5.1.3.1. clauses 5.2, 5.3.1 (excluding 5.3.1.3 and 5.3.1.4), 5.3.2, 5.3.3 and 17 to 19; or
- 5.1.3.2. clause 5.1.1.; or
- 5.1.3.3. clause 5.1.2 (except that cl. 5.3.2 and 5.3.3 must be complied with).
- 5.2. 'Seatbelts Assemblies' of a type determined by the 'Anchorage' system must be fitted to each seating position for which seatbelt 'Anchorages' are required in accordance with ADR 5/... .
- 5.2.1. Threaded steel bolts of 7/16 inch - 20 UNF - 2A are recommended for attachment to the vehicle.
- 5.3. Type of 'Seatbelt Assembly'
- 5.3.1. A 'Lap-Sash Belt' or 'Harness Belt' must:
- 5.3.1.1. when fitted to the driver's seating position incorporate an 'Emergency Locking Retractor'.
- 5.3.1.1.1. Where the driver's 'Seat' is a 'Suspension Seat' and not all the 'Anchorages' are mounted on the moving part of the 'Seat', the retractor must be a 'Type 4N Retractor'.
- 5.3.1.2. when fitted to the other front 'Outboard Seating Position', incorporate an 'Emergency Locking Retractor' or an 'Automatic Length Adjusting and Locking Retractor';
- 5.3.1.3. when fitted to any 'Outboard Seating Position' of a 'Second Row Seat' incorporate an 'Emergency Locking Retractor' or an 'Automatic Length Adjusting and Locking Retractor'; and
- 5.3.1.4. when fitted to any 'Outboard Seating Position' other than the driver's seating position in a forward-control passenger vehicle (MB); or an omnibus (MD1 and MD2) incorporate an 'Emergency Locking Retractor' or an 'Automatic Length Adjusting and Locking Retractor'.

- 5.3.2. For an ME or NC vehicle, a *'Lap Belt'* must incorporate an *'Emergency Locking Retractor'* when fitted to the driver's seating position.
- 5.3.3. For an ME or NC vehicle, a *'Lap Belt'* must, incorporate either an *'Emergency Locking Retractor'* or an *'Automatic Length Adjusting and Locking Retractor'* when fitted to the other front *'Outboard Seating Position'*.
- 5.4. Removal of the *'Seatbelt Assembly'* from the vehicle or separation of any *'Functional Components'* must not be possible without the use of tools except in the case of:
- 5.4.1. the unlatching of the *'Buckle Components'*;
- 5.4.2. a *'Sash Guide'* device which is both:
- 5.4.2.1. designed to separate from its supporting structure or fail to retain the strap upon application of the *'Anchorage'* test loads ADR 5/... ; and
- 5.4.2.2. for which more than one point of attachment to the vehicle is available to provide the occupant with a choice of sash *'Strap'* positions relative to his shoulder; or
- 5.4.3. the torso *'Strap'* of a *'Lap-Sash Belt'* *'Seatbelt Assembly'* fitted to an *'Outboard Seating Position'* where the seat is designed to provide adjustment for conversion of occupant space to luggage or goods space and such seating position is not the driver's or front *'Seat'* passenger's seating position or the seating position immediately to the rear thereof.
- 5.4.4. The provisions of clause 5.4.3 above must apply notwithstanding the requirements of clause 5 of AS 2596-1983 "Seat Belt Assemblies for Motor Vehicles".
- 5.5. In the case where a *'Lap-Sash Belt'* *'Seatbelt Assembly'* is provided with a torso *'Strap'* designed to be removed or separated from the *'Seatbelt Assembly'* in accordance with the provisions of clause 5.4 the requirements of this rule must apply to the *'Seatbelt Assembly'* as:
- 5.5.1. a *'Lap-Sash Belt'* with the torso *'Strap'* operative; or
- 5.5.2. a *'Lap Belt'* with the sash *'Strap'* so removed or separated.
- 5.6. Any single component of the *'Seatbelt Assembly'* having a mass in excess of 75 g other than a *'Strap'*, *'Anchor Fitting'* or *'Sash Guide'* device must be located in areas other than that area forward of the *'Torso Reference Line'* and between Line A and Line B when the assembly is correctly fitted for a *'95th Percentile Adult Male'* and *'50th Percentile 6 Years Old Child'* independently.
- 5.7. Each *'Seatbelt Assembly'* must be permanently and legibly marked with at least the manufacturer's name or trade mark, date of manufacture by month and year, and identification code. The identification code must be a number and/or symbol which

- uniquely identifies the ‘*Seatbelt Assembly*’ or sub-assembly design.
- 5.7.1. The same identification code may be used on two or more assembly or sub-assembly designs which are identical except for variations in ‘*Strap*’ length which do not exceed:
- 5.7.1.1. 25 mm in the case of a ‘*Strap*’ which has a length critical to the correct location of the ‘*Lap-Sash Point*’; or
- 5.7.1.2. 100 mm in the case of other ‘*Straps*’.
- 5.7.2. Furthermore, where a manufacturer, for “in-service” replacement purposes, provides for replacement of parts of a ‘*Seatbelt Assembly*’ rather than the assembly as a whole, each of the 2 sub-assemblies of the ‘*Seatbelt Assembly*’ which can be separated from each other by the normal unlatching process must be permanently and legibly marked in accordance with the requirements of this clause.
- 5.8. ‘*Seatbelt Assemblies*’ must comply with either:
- 5.8.1. The AS 2596 referred to in clause 5.4.4 of this rule but excluding clauses 1,2,4,15,16,17,18 and AS 2597.13 - 1983: “Determination of Dynamic Performance”;
- 5.8.1.1. the maximum dummy displacement limit in AS 2596-1983 section 14.1 (c), does not apply to ‘*Seatbelt Assemblies*’ required to comply with ADR 69/...
- 5.8.1.2. ‘*Seatbelt Assemblies*’ required to comply with ADR 69/... need not comply with the elongation and Hysteresis requirements specified in section 6.5 of AS 1753 - 1990; or
- 5.8.2. any other ‘*Approved*’ standard accepted as equivalent.
- 5.9. Instructions for use of ‘*Seatbelt Assemblies*’ must be included in the vehicle handbook, or otherwise supplied with the vehicle. The instructions must include the following text:
- 5.9.1. “WARNING: Seatbelts are designed to bear upon the bony structure of the body, and should be worn low across the front of the pelvis or the pelvis, chest and shoulders, as applicable; wearing the lap section of the belt across the abdominal area must be avoided.
- “Seatbelts should be adjusted as firmly as possible, consistent with comfort, to provide the protection for which they have been designed. A slack belt will greatly reduce the protection afforded to the wearer.
- “Care should be taken to avoid contamination of the webbing with polishes, oils and chemicals, and particularly battery acid. Cleaning may safely be carried out using mild soap and water. The belt should be replaced if webbing becomes frayed, contaminated or damaged.

“It is essential to replace the entire assembly after it has been worn in a severe impact even if damage to the assembly is not obvious.

“Belts should not be worn with straps twisted.

“Each belt assembly must only be used by one occupant; it is dangerous to put a belt around a child being carried on the occupant’s lap.”

- 5.9.2. In the case where a ‘Seatbelt Assembly’ incorporates an ‘Automatic Length Adjusting and Locking Retractor’ or an ‘Emergency Locking Retractor’:
- 5.9.2.1. “WARNING: No modifications or additions should be made by the user which will either prevent the seat belt adjusting devices from operating to remove slack, or prevent the seat belt assembly from being adjusted to remove slack.”; plus
- 5.9.2.2. a description of the adjustments necessary to ensure that the lap and sash portions of the ‘*Seatbelt Assembly*’ fit as firmly as possible consistent with comfort; and
- 5.9.2.3. instructions on the correct use of any device or devices included in the ‘*Seatbelt Assembly*’ which, upon manual or automatic operation, prevent the belt from being retracted.
- 5.10. When installed the ‘*Seatbelt Assembly*’ webbing must not contact any sharp edges which could abrade or cut the webbing during normal use or in an accident. If necessary, the webbing must be protected.

6. ADJUSTMENT REQUIREMENTS

- 6.1. Each ‘*Seatbelt Assembly*’ must be so designed that, with the adjustment provided, it must be capable of being ‘*Correctly Fitted*’ for:
- 6.1.1. in the case of the driver’s seating position, a ‘*5th Percentile Adult Female*’ with the seat in the rearmost driving position and a ‘*95th Percentile Adult Male*’ with the ‘*Seat*’ in the foremost driving position; and
- 6.1.2. if installed at any other seating position, a ‘*50th Percentile 6 Years Old Child*’ with the ‘*Seat*’ in the rearmost riding position and a ‘*95th Percentile Adult Male*’ with the ‘*Seat*’ in the foremost riding position.
- 6.1.3. Furthermore, in the case of the fittings to the ‘*95th Percentile Adult Male*’ in 6.1.1 and 6.1.2 above, the design must provide for at least 75 mm of additional ‘*Strap*’ in a ‘*Lap Belt*’ and at least 75 mm of additional ‘*Strap*’ in both the lap ‘*Strap*’ and upper torso ‘*Strap*’ of a ‘*Lap-Sash Belt*’ or ‘*Harness Belt*’. The purpose of this clause is to accommodate a stouter person than represented by the 95th percentile anthropometric dimensions.

- 6.2. In the case of a *'Seatbelt Assembly'* incorporating a manual adjusting device, the following requirements must be met when the assembly is correctly fitted for a *'95th Percentile Adult Male'* and a *'50th Percentile 6 Years Old Child'* independently, when the *'Seat'* is in the foremost riding or driving position (Figure 2 refers):
- 6.2.1. for tightening, the adjustment must be by a single action at an *'Accessible'* point which lies between Line C and Line E and *'Forward'* of Line FOS; and
- 6.2.2. for loosening, the entire adjusting device must lie between Line C and Line D and *'Forward'* to Line KPS and there must be one point on the device which is *'Accessible'*.
- 6.2.3. For the purpose of determining whether the point is *'Accessible'*, the dummy or occupant may be removed.
- 6.3. Any free end of a *'Strap'* must:
- 6.3.1. be designed so as to prevent it from passing through the adjuster under normal adjustment operations, and with the strap fully extended the *'Strap'*/adjuster combination must be capable of withstanding, for not less than 30 seconds a static tensile load of 9 kN applied to the load bearing end of *'Strap'* with the adjuster restrained as in the vehicle; and
- 6.3.2. be restrained by a positive design feature to adopt a position against another *'Strap'*. The free end of a *'Strap'* on any seat belt for a centre seating position or for an *'Outboard Seating Position'* not adjacent to a vehicle door need not meet this requirement.
- 6.3.3. Further, with the *'Strap'* fully extended, there must be not less than 25 mm of material extending from the device to provide a grip for adjustment purposes. The material may either be attached to or form part of the free end of the *'Strap'*.

7. BUCKLE REQUIREMENTS

- 7.1. It must not be possible to adjust a *'Lap-Sash Belt'* so that when correctly fitted for a *'5th Percentile Adult Female'*, the *'Lap Sash Point'* is less than 125 mm in the case of *'Seats'* with *'Forward'* and *'Rearward'* adjustment, or 175 mm in the case of fixed *'Seats'*, from the *'Seating Reference Plane'* when measured along the centreline of the pelvic restraint section of the belt. This requirement must be met with the *'Seat'* in its foremost and rearmost driving or riding position and with the *'Seat'* back at the design *'Seat Back Angle'*.
- 7.2. In cases where the *'Buckle Component'* of a *'Lap-Sash Belt'* *'Strap'* can be latched with part of an assembly intended for an adjacent seating position, the design must be such that the requirements of clause 7.1 are met irrespective of the combination used.

- 7.3. In cases where the *'Buckle Component'* of a *'Seatbelt Assembly'* can be engaged either wholly or partially with the *'Buckle Component'* of a *'Seatbelt Assembly'* intended for an adjacent seating position, the design must be such that the *'Seatbelt Assembly'* so formed must comply with the requirements of clause 14 of the AS 2596 - 1983 "Seat Belt Assemblies for Motor Vehicles".
- 7.3.1. This requirement must apply irrespective of whether the wholly or partially engaged components will separate without operation of the unlatching device.
- 7.3.2. This requirement must not apply in cases where *'Seatbelt Assemblies'* fitted to adjacent seating positions are from the same manufacturer and have the same buckle design.
- 7.4. In the case of a *'Lap-Sash Belt'* incorporating a retractor, the design must be such that in the fully retracted position, the *'Buckle Component'* associated with the retracting *'Strap'* must adopt a position that is either:
- 7.4.1. *'Accessible'*; and
- 7.4.2. within 300 mm of both foremost and rearmost points on the *'Seating Reference Locus'* when viewed in side elevation or within 300 mm of Point 0 and Point N when viewed in side elevation; and
- 7.4.3. within 400 mm of the *'Seating Reference Plane'* when viewed in plan; or
- 7.4.4. can be moved to a position which meets the requirements of clauses 7.4.1 to 7.4.3 above by a manual operation applied to the assembly at points which meet the requirements of clauses 7.4.1 to 7.4.3.
- 7.4.5. This requirement must not apply to a seating position adjacent to an access door, where the *'Seat'* must hinge or fold to permit access to another seating position.
- 7.5. In the case of a vehicle with one front seating position only, or with 2 front *'Seats'* each providing for one seating position only, the *'Buckle Component'* on that part of a *'Lap-Sash Belt'* which does not include the retracting *'Strap'* must be supported by a rigid member which may pivot, or in such a manner that after being correctly fitted for a *'95th Percentile Adult Male'* with the *'Seat'* in the foremost driving or riding position, unlatching of the buckle assembly and removal of the occupant from the seating position does not result in any point on the component moving downwards such that the vertical component of movement is more than 50 mm.
- 7.5.1. When unlatched after the assembly has been correctly fitted for a *'95th Percentile Adult Male'* with the *'Seat'* in the foremost driving or riding position and a *'5th Percentile Adult Female'* with the *'Seat'* in the rearmost driving or riding position, independently, there must be a point on the component which is:

- 7.5.1.1. 'Accessible';
- 7.5.1.2. within 300 mm of both the foremost and rearmost points on the '*Seating Reference Locus*' when viewed in side elevation; and
- 7.5.1.3. within 150 mm to 400 mm of the '*Seating Reference Plane*' when viewed in plan.
- 7.5.2. For the purpose of determining whether the point is '*Accessible*', the dummy or occupant may be removed.
- 7.6. In the case of outboard seating positions not provided for in clause 7.5 the part of the assembly which does not include the '*Strap*' designed to pass over the torso of the occupant must be so restrained by a positive design feature that one point at least cannot pass '*Rearward*' of the line of contact of the '*Seat*' cushion with the '*Seat*' back.
- 7.6.1. The line of contact of the '*Seat*' cushion with the '*Seat*' back is the front boundary of the area of contact across the '*Seat*' width of the '*Seat*' cushion with the '*Seat*' back when the '*Seat*' cushion is unoccupied.
- 7.6.2. The requirements of clause 7.6 must be met when a folding or hinged '*Seat*' is in its normal position. Re-establishment of such a '*Seat*' may include a manual operation to re-establish part of the '*Seatbelt Assembly*'.
- 7.7. In the case of '*Lap-Sash Belt*' assemblies not incorporating '*Emergency Locking Retractors*', or '*Automatic Length Adjusting and Locking Retractors*' fitted to outboard seating positions vehicles.
- 7.7.1. The design must provide for a stowage feature for the part of the assembly which includes the '*Strap*' designed to pass over the pelvis or torso of the occupant, to facilitate that part of the assembly, when unlatched, being kept clear of the vehicle floor and the lower edge of the door opening.
- 7.8. The area of vehicle floor does not include areas which are inaccessible to the occupant's feet during travel or during entry and exit.

8. GENERAL REQUIREMENTS FOR SEATBELT COMPONENTS

- 8.1. In all cases where the '*Strap*' passes through another component, other than a '*Sash Guide*' used in conjunction with an '*Emergency Locking Retractor*', and there is relative movement between the '*Strap*' and the component as a result of adjusting operations, the tensile strength of the webbing must not be reduced to less than 14.7 kN or 75% of the '*Dry Breaking Strength*', whichever is the greater, after 2,500 cycles of relative movement under the following test conditions:
- 8.1.1. the tensile load in all parts of the test '*Strap*' during the working stroke of the 2 strokes of each cycle must be not less than 13 N;

- 8.1.2. the working stroke must be not less than 150 mm nor more than 200 mm; and
- 8.1.3. the angle which the centreline of each end of the test *'Strap'* makes with the component must be not less critical to *'Strap'* abrasion than that nominated by the vehicle *'Manufacturer'* as representative of such angle of the *'Strap'* in use, when the assembly is correctly fitted for a *'5th Percentile Adult Female'* with the *'Seat'* in the rearmost driving or riding position, except that in the case where the design provides for the centrelines of the straps to be separated when viewed normal to the plane of one *'Strap'*, then such angle of separation in the test may be any angle greater than 25°, and the angle of separation of the centrelines of the *'Straps'* when viewed in the plane of one *'Strap'* may be any angle less than 10°.
- 8.2. In the case of a *'Lap-Sash Belt'* incorporating an *'Emergency Locking Retractor'* (other than a *'Type 4N Retractor'*), where, during the wearing and retracting operations, there is relative movement between the retracting *'Strap'* and the *'Sash Guide'* system other than the retractor itself the tensile strength of the webbing must not be reduced to less than 14.7 kN or 75% of the *'Dry Breaking Strength'*, whichever is the greater, after the retracting *'Strap'* has been drawn through the *'Sash Guide'* system for 50,000 cycles under the following test conditions:
- 8.2.1. the tensile load in all parts of the test *'Strap'* during the working stroke of the 2 strokes of each cycle must not be less than 18 N;
- 8.2.2. the tensile load in the test *'Strap'* at one point in the cycle must be reduced to zero;
- 8.2.3. the working stroke must be not less than 200 mm;
- 8.2.4. the orientation of the test *'Strap'* relative to the *'Sash Guide'* must be such that:
- 8.2.4.1. the *'Sash Guide'* must be in its design configuration except that, for *'Sash Guides'* designed to pivot, the angle of the axis of rotation may vary from its design configuration provided that such variation is not greater than 5°,
- 8.2.4.2. the part of the test *'Strap'* which simulates the *'Strap'* passing from the *'Sash Guide'* to the next *'Sash Guide'* or to the retractor, must be in the design configuration; and
- 8.2.4.3. the part of the test *'Strap'* which simulates the torso *'Strap'* must be pulled in a vertical plane not more than 45° or a longitudinal plane when viewed in plan, and the direction of pull in that plane must vary over a range of not less than 65° during the working stroke of each cycle; and
- 8.2.5. all *'Sash Guides'* for the one assembly must be tested simultaneously.

8.2.6. The requirements of this clause must not apply to relative movement between the 'Strap' and the retractor, at the retractor.

8.3. Buckle-Spring Fatigue Resistance

8.3.1. In the case where a spring is incorporated in the unlatching mechanism of a buckle, the load required to operate the spring must not be reduced by more than 20% after the spring has been subjected to 50,000 operations each involving a movement not less than 95% of the design movement for buckle unlatching.

9. RETRACTORS (OTHER THAN 'TYPE 4N RETRACTORS')

9.1. All retractors incorporated in 'Seatbelt Assemblies' must comply with the requirements of clause 9.2 and either clause 9.3 or 9.4.

9.2. General Requirements for Retractors

9.2.1. After being subjected to the retractor durability test of clause 11, the retractor must:

9.2.1.1. when locked, either:

9.2.1.1.1. withstand a tensile load of not less than 9 kN applied to the 'Strap';
or

9.2.1.1.2. be subjected to the strength of assembly test of clause 14.1 of AS 2596-1983 "Seat Belt Assemblies for Motor Vehicles".

9.2.1.2. withstand a tensile load of not less than 9 kN applied to the 'Strap'. For the purpose of this test the 'Strap' must be fully withdrawn and the locking mechanism must be rendered inoperative.

9.2.2. In cases where the retracting 'Strap' of a 'Lap-Sash Belt' is the torso 'Strap', the retraction force in the 'Strap' before and after the retractor has been subjected to the retractor durability test of clause 11, must be not less than 2 N nor more than 10 N, under the following test conditions:

9.2.2.1. the 'Sash Guide' system and the retractor must be in the design configuration. In the case of a 'Sash Guide' system with an adjustable 'Sash Guide' the retractor must be capable of meeting the requirements of this clause with the 'Sash Location Point' set in any position of adjustment;

9.2.2.2. the part of the test 'Strap' which simulates the torso 'Strap' must be withdrawn through the 'Sash Guide' system until it is within 430 mm of its fully extended condition;

9.2.2.3. the 'Strap' must be allowed to retract until a point on the 'Strap' is 450 ± 20 mm, measured along the 'Strap' from its position when the 'Strap' is fully extended. It must then be held stationary at this extension by a force applied in a downward direction at $20 \pm 10^\circ$ to the vertical in a vertical plane which is at $35 \pm 10^\circ$ to a longitudinal plane when viewed in plan, and must not be withdrawn again until the retracting force has been determined;

- 9.2.2.4. the retraction force must be measured in the test ‘*Strap*’ ‘*Forward*’ of the point where it would contact the first ‘*Sash Guide*’ device after passing over the shoulder of the wearer; and
- 9.2.2.5. where the assembly incorporates a device that upon manual or automatic operation, prevents the belt from being completely retracted, such a device must not be operating when this requirement is assessed.
- 9.3. ‘Automatic Length Adjusting and Locking Retractors’
The locking mechanism of an ‘*Automatic Length Adjusting and Locking Retractor*’ must be designed to provide a locked position for at least every 30 mm of ‘*Strap*’ extension from the position when the ‘*Seatbelt Assembly*’ is correctly fitted for a ‘*50th Percentile 6 Years Old Child*’, with the ‘*Seat*’ in the rearmost riding position.
- 9.4. ‘Emergency Locking Retractors’ (other than ‘Type 4N Retractors’, see Appendix A).
- 9.4.1. ‘*Emergency Locking Retractors*’ must lock when the retractor and any associated devices to sense acceleration are accelerated at not more than 5 m/s^2 , the peak acceleration being attained in not less than 40 milliseconds.
- 9.4.2. Furthermore with a point on the external ‘*Strap*’ fixed the locking device must limit ‘*Strap*’ movement, measured from the time of application of the acceleration, to not more than:
- 9.4.2.1. 30 mm, when the ‘*Strap*’ is withdrawn to a point which is 150 ± 5 mm from the fully extended position; and
- 9.4.2.2. 80 mm, when the ‘*Strap*’ is withdrawn to points 450 ± 5 mm and 760 ± 5 mm from the fully extended position, if the ‘*Seatbelt Assembly*’ includes sufficient ‘*Strap*’ to attain these extensions.
- 9.4.3. This requirement must be met under positive and negative acceleration in longitudinal, transverse and vertical directions, except that in cases where the device is designed to lock when tilted to any angle in excess of 45° then the locking requirement need be met for longitudinal and transverse directions only.
- 9.4.4. Sensing of acceleration to meet the requirements of this clause must not be dependent upon rate of withdrawal of ‘*Strap*’ from the retractor. In demonstrating this requirement, any device dependent for sensing of acceleration on withdrawal of ‘*Strap*’ from the retractor may be rendered inoperative.
- 9.4.5. ‘*Emergency Locking Retractors*’ must be designed in such a way that when the ‘*Strap*’ is extended at an acceleration of not more than 20 m/s^2 locking occurs within 25 mm of ‘*Strap*’ extension. This requirement must be met at an extrapolated point representing full extension based on test results achieved at points of extension which are less than the full extensions by 150 ± 5 mm, 450 ± 5 mm, and 750 ± 5 mm (if available), respectively.

- 9.4.6. An *'Emergency Locking Retractor'* must be designed to lock automatically, or meet the requirements of clauses 9.4.1 and 9.4.5 upon any single mechanical failure of a spring which is part of the locking mechanism.
- 9.4.7. In cases where the operation of a retractor depends on an external signal or power source, the design must ensure that the retractor locks automatically upon failure or interruption of that signal or power source.
- 9.4.8. The design of an *'Emergency Locking Retractor'* must ensure that it remains unlocked when the vehicle is tilted up to 12°, longitudinally or transversely, from the horizontal.

10. DYNAMIC TEST REQUIREMENTS

- 10.1. *'Seatbelt Assemblies'* for front facing *'Seats'* must not separate within themselves or from any *'Anchorage'*, when tested in accordance with the dynamic test procedure of clause 12.
- 10.2. Prior to the dynamic test, each *'Seatbelt Assembly'* must be subjected to the preconditioning requirements of clause 10.3.
- 10.3. Dynamic Test Preconditioning
- 10.3.1. Any *'Buckle Component'* or manual adjusting device which can take up a position in a door opening, or under a pivoting *'Seat'*, must be placed on a flat surface in its most stable position and subjected to a force of not less than 1.8 kN for a period of not less than 10 seconds. The force must be applied through a rigid bar of diameter not more than 20 mm formed to an arc of radius not more than 150 mm, with the bar in line with the *'Strap'* when viewed in plan, and the test must be repeated with the bar normal to the direction of the *'Strap'* when viewed in plan.
- 10.3.2. The buckle assembly must be subjected to not less than 20,000 unlatching operations. During each unlatching operation a tensile load of not less than 20 N must be applied to the assembly.
- 10.3.3. Each *'Seatbelt Assembly'* which contains non-metallic material (other than a webbing *'Strap'*) must be exposed to environment over a water surface within a closed space, the environment having a temperature of not less than 80°C, for a continuous period of not less than 24 hours and then cooled in an environment having a temperature not exceeding 23°C. The cooling period must immediately be followed by three consecutive 24 hour cycles with each cycle comprising the following consecutive sequences:
- 10.3.3.1. an environment having a temperature of not less than 100°C must be maintained for a continuous period of 6 hours and this environment must be attained within 80 minutes of commencement of the cycle; then

- 10.3.3.2. an environment having a temperature of not more than 0°C must be maintained for a continuous period of 6 hours and this environment must be attained within 20 minutes; then
- 10.3.3.3. an environment having a temperature of not more than 23°C must be maintained during the remainder of the 24 hour cycle.

11. RETRACTOR DURABILITY TEST

The '*Seatbelt Assembly*' must be prepared, conditioned and tested to AS 2597.9-1983 "Preparation and Conditioning of Test Specimens for Retractor Function".

12. DYNAMIC TESTING PROCEDURE

- 12.1. The test rig must have a mass of not less than 380 kg and must meet the requirements of clause 15 for test rig calibration. It must comprise either:
 - 12.1.1. a trolley and '*Seat*' as specified in clauses 14.1 and 14.2 for dummy calibration, and with '*Anchorage*' and '*Sash Guide*' devices within 100 mm of their design positions with the test seat datum point assumed to coincide with the '*Seating Reference Point*'; or
 - 12.1.2. a trolley and a vehicle body shell complete with a representative '*Seat*' adjusted to the rearmost driving or riding position.
- 12.2. A dummy meeting the requirements of clause 13 must be placed in the appropriate seating position so that its centre-line lies in the '*Seating Reference Plane*' and such that it is restrained by the '*Seatbelt Assembly*' as follows:
 - 12.2.1. in the case of '*Seatbelt Assemblies*' incorporating retractors, the belt must be manually adjusted around the dummy to eliminate slack; and
 - 12.2.2. in the case of other '*Seatbelt Assemblies*', a spacer of flexible but substantially incompressible material not less than 25 mm thick and at least as wide and as long as the dummy's back must be placed behind the back of the dummy. The assembly must be adjusted to eliminate slack and the spacer then removed. The dummy must be re-positioned so that its back is in contact with the '*Seat*' back.
- 12.3. The rig must be operated in a manner identical in all operational respects to that specified in clause 15.1 for rig calibration except that in this case the dummy replaces the inert mass.

13. TEST DUMMY REQUIREMENTS

- 13.1. The dummy must have a mass of 74 ± 2 kg.
- 13.2. When tested in accordance with the requirements of clause 14 for dummy calibration, the test dummy must give rise to '*Seatbelt Assembly*' loads such that the sum of the peak restraining forces in each length of the sash '*Strap*' which is not in contact with the

dummy is not less than 10 kN, and also that the sum of the peak restraining forces in each length of the lap 'Strap' which is not in contact with the dummy is not less than 10 kN.

14. DUMMY CALIBRATION

- 14.1. The test rig must have a mass of not less than 380 kg and, must meet the requirements of clause 15 for test rig calibration. It must comprise a trolley, test 'Seat', foot rest, and structure for providing seatbelt 'Anchorages', meeting the dimensional requirements indicated in Figure 1.
- 14.2. The 'Seat' base surface must not be designed with energy absorbing characteristics and must present a smooth surface for the dummy.
- 14.3. The dummy must be restrained by separate 'Lap Belts' and sash belts, each of which comprises load bearing material having an elongation of not less than 12% when subjected to a load of 11 kN. The method of test of elongation must be determined by the method described in AS 1753-1975: "Webbing for Restraining Devices for Occupants of Motor Vehicles", except that the specimen must be loaded to 11 kN in lieu of the load specified in the Australian Standard.
- 14.4. The 'Lap Belts' and sash belts must be adjusted to eliminate slack.
- 14.5. The rig must be operated in a manner identical in all operational respects to that specified in clause 15.2 for rig calibration except that in this case the dummy replaces the inert mass.

15. TEST RIG CALIBRATION

- 15.1. In the case of calibration prior to seat belt testing, the test rig, to which a mass of 74 ± 2 kg is rigidly attached, when subjected to a velocity change of not less than 49 km/h, must achieve within 30 milliseconds a 'Forward' deceleration measured in the vicinity of a lap 'Anchorage' of at least 235 m/s^2 and must maintain this deceleration, except for periods of less than one millisecond, for not less than 20 milliseconds.
- 15.2. In the case of calibration prior to proving the dummy, the test rig, to which a mass of 74 ± 2 kg is rigidly attached, when subjected to a velocity change of not less than 49 km/h, must achieve within 30 milliseconds, a 'Forward' deceleration measured in the vicinity of a lap 'Anchorage', within the range 235 to 335 m/s^2 and must maintain this deceleration, except for periods of less than one millisecond, for not less than 20 milliseconds.

16. COMPONENT BOUNDARY LOCATION

- 16.1. The lines shown in Figure 2 in side elevation are established as follows:

- 16.1.1. Line A is a horizontal line 850 mm above the '*Seating Reference Point*';
- 16.1.2. Line B is a horizontal line 330 mm above the '*Seating Reference Point*';
- 16.1.3. Line C is a horizontal line 680 mm above the '*Seating Reference Point*';
- 16.1.4. Line D is a horizontal line 150 mm below the '*Seating Reference Point*';
- 16.1.5. Line E is a horizontal line 75 mm below the '*Seating Reference Point*';
- 16.1.6. Line FOS consists of 2 lines FO and OS and is constructed as follows:
 - 16.1.6.1. draw line FO parallel to the '*Torso Reference Line*' and intersecting Line G at Point O, such that the extension of Line FO passes through the most '*Forward*' point on the '*Seating Reference Locus*'; and
 - 16.1.6.2. draw a vertical Line OS intersecting Line G at Point O;
- 16.1.7. Line KPS consists of 2 Lines KP and PS and is constructed as follows:
 - 16.1.7.1. draw Line KP parallel to and 100 mm '*Rearward*' of Line FO (established above) intersecting Line OS at P; and
 - 16.1.7.2. Line PS is coincident with Line OS,
- 16.1.8. Line G is a horizontal Line 380 mm above the '*Seating Reference Point*', intersecting the '*Torso Reference Line*' at Point N; and
- 16.1.9. Line J is a horizontal Line 230 mm above the '*Seating Reference Point*'.

17. DETAILED REQUIREMENTS FOR VEHICLE CATEGORIES MD3, MD4, ME, NB2 AND NC ONLY

- 17.1. Separation of any '*Functional Components*' of the '*Seatbelt, Assembly*', other than unlatching of the '*Buckle Components*', must not be possible without the use of tools.
- 17.2. '*Seatbelt Assemblies*' must comply with either:
 - 17.2.1. AS 2596-1983, as referenced in clause 5.8.1 but excluding clauses 1,2,4,15,16,17,18 of AS 2596 and excluding dynamic testing to the AS 2597 referred to in clause 5.8.1 provided that the maximum test load must not be less than 9 kN and the corrosion conditioning procedure must be that specified in clause 18;
 - 17.2.2. Federal Motor Vehicle Safety Standard No. 209, "Seat Belt Assemblies" current as at 13 December 1979 except that the use of non-locking retractors as defined in that Standard are not allowed;

- 17.2.3. ECE Regulation 16/04, "Safety Belts" (except that the use of a non-locking retractor as defined in that Regulation IS not allowed.); or
- 17.2.4. Any other 'Approved' standard accepted as equivalent.
- 17.3. The operation of any 'Emergency Locking Retractor' (including a 'Type 4N Retractor') incorporated in a 'Seatbelt Assembly' must not be dependent solely upon rate of withdrawal of 'Strap' from the retractor.
- 17.4. In the case of a non-'Suspension Seat' where the 'Seatbelt Assembly' is not mounted on the 'Seat' the 'Buckle Component' which does not include the retracting 'Strap' must comply with the accessibility requirements of clause 7.5.1.
- 18. CORROSION CONDITIONING PROCEDURE FOR SEATBELT ASSEMBLIES FITTED IN ACCORDANCE WITH CLAUSE 17**
- 18.1. The 'Seatbelt Assembly' must be conditioned by the procedure specified in the ASTM B117-64 "Standard Method of Salt Spray (Fog) Testing".
- 18.2. The period of conditioning must be not less than 50 hours, and at the end of the conditioning procedure specified in clause 18.1 the 'Seatbelt Assembly' may be washed thoroughly with water to remove the salt. If washed, the webbing must be fully extended and allowed to dry for at least 24 hours in an atmosphere having a relative humidity of not less than 48% nor more than 67% and a temperature of not less than 21°C nor more than 25°C. The webbing must then be withdrawn manually and allowed to retract for 25 cycles.
- 19. ADJUSTMENT REQUIREMENTS FOR VEHICLE CATEGORIES MD3, MD4, ME, NB2 AND NC ONLY**
- 19.1. With the 'Seatbelt Assembly' in the unlatched condition, a point on each separate portion of the seat belt must be located by a design feature to adopt a position not more than 100 mm below the top edge of the seat cushion measured in the immediate vicinity of such a design feature.
- 19.2. Any free end of a 'Strap' must be restrained by a design feature to adopt a position against another 'Strap'.
- 19.3. With the 'Strap' fully extended, there must be not less than 25 mm of material extending from the adjusting device to provide a grip for adjustment purposes. The material may either be attached to or form part of the free end of the 'Strap'.
- 20. ALTERNATIVE STANDARDS**
- 20.1. The technical requirements of ECE R 16/04 "Safety Belts" must be deemed to be equivalent to the technical requirements of this rule, provided that

- 20.1.1. the free end requirements of clauses 6.3.2 or 19.2 of this rule are met.
- 20.2. The technical requirements of AS/NZS 2596:1995 Seat Belt Assemblies for Motor Vehicles are deemed to be equivalent to the technical requirements of this rule, provided that
 - 20.2.1. non locking retractors are not used
 - 20.2.2. the free end requirements of clauses 6.3.2 or 19.2 of this rule are met..

TABLE 1
DUMMY DIMENSIONS ##

	<i>'95th Percentile Adult Male'</i>	<i>'5th Percentile Adult Female'</i>	<i>'50th Percentile 6 Years Old Child'</i>
Mass	97.5 ± 5 kg	46 ± 5 kg	21.4 ± 3 kg
Erect sitting height	965 mm	785 mm	645 mm
Hip breadth (sitting)	415 mm	325 mm	215 mm
Hip circumference (sitting)	1200 mm	925 mm	605 mm
Waist circumference (sitting)	1080 mm	600 mm	530 mm
Chest depth	265 mm	190 mm	160 mm
Chest circumference	1130 mm	775 mm (nipple) 755 mm (upper) 675 mm (lower)	595 mm
Shoulder height	680 mm	520 mm	415 mm

Tolerance on all length dimensions ± 5 percent

**FIGURE 1
TEST SEAT and ANCHORAGES**

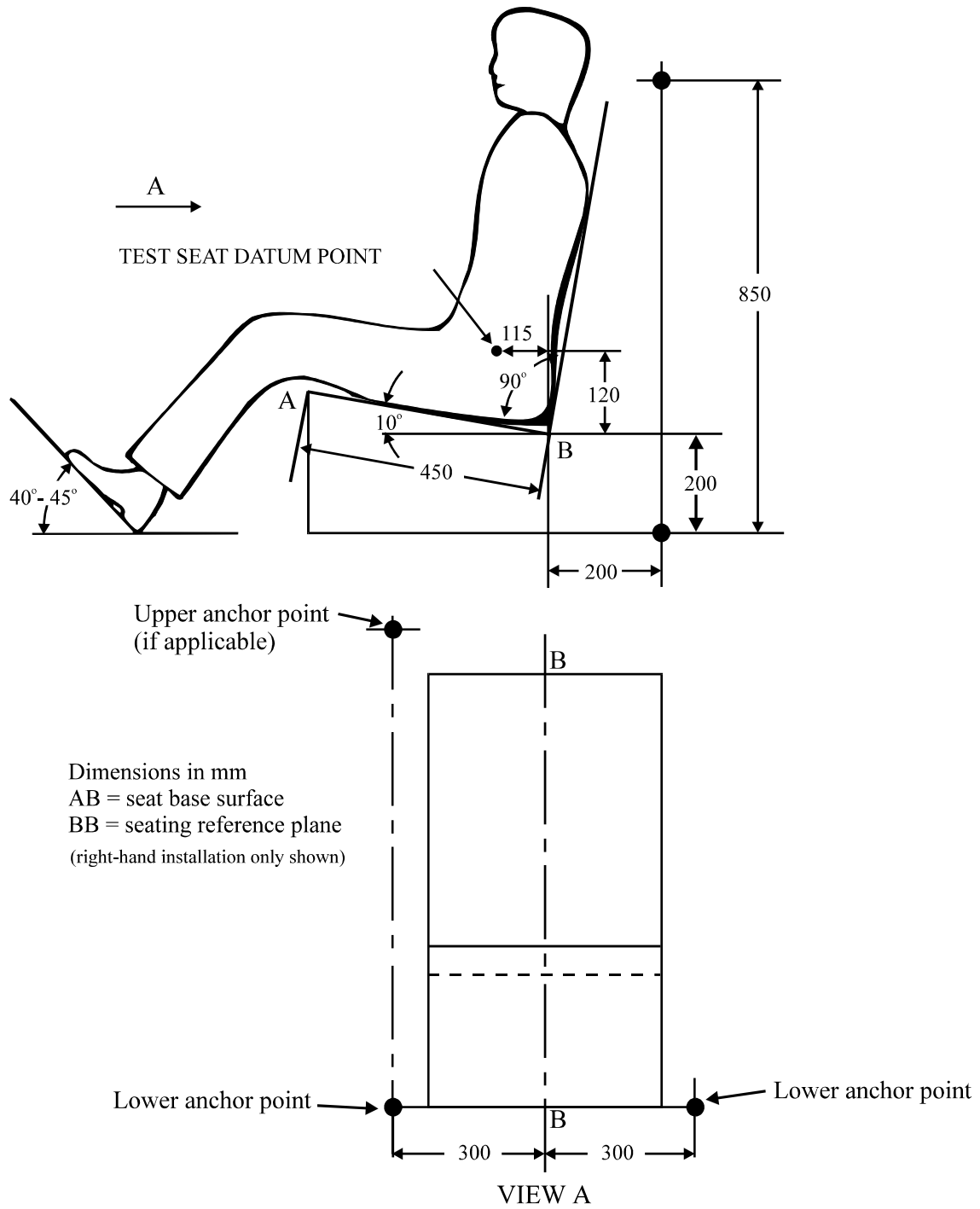

**FIGURE 2
COMPONENT BOUNDARY LOCATION**

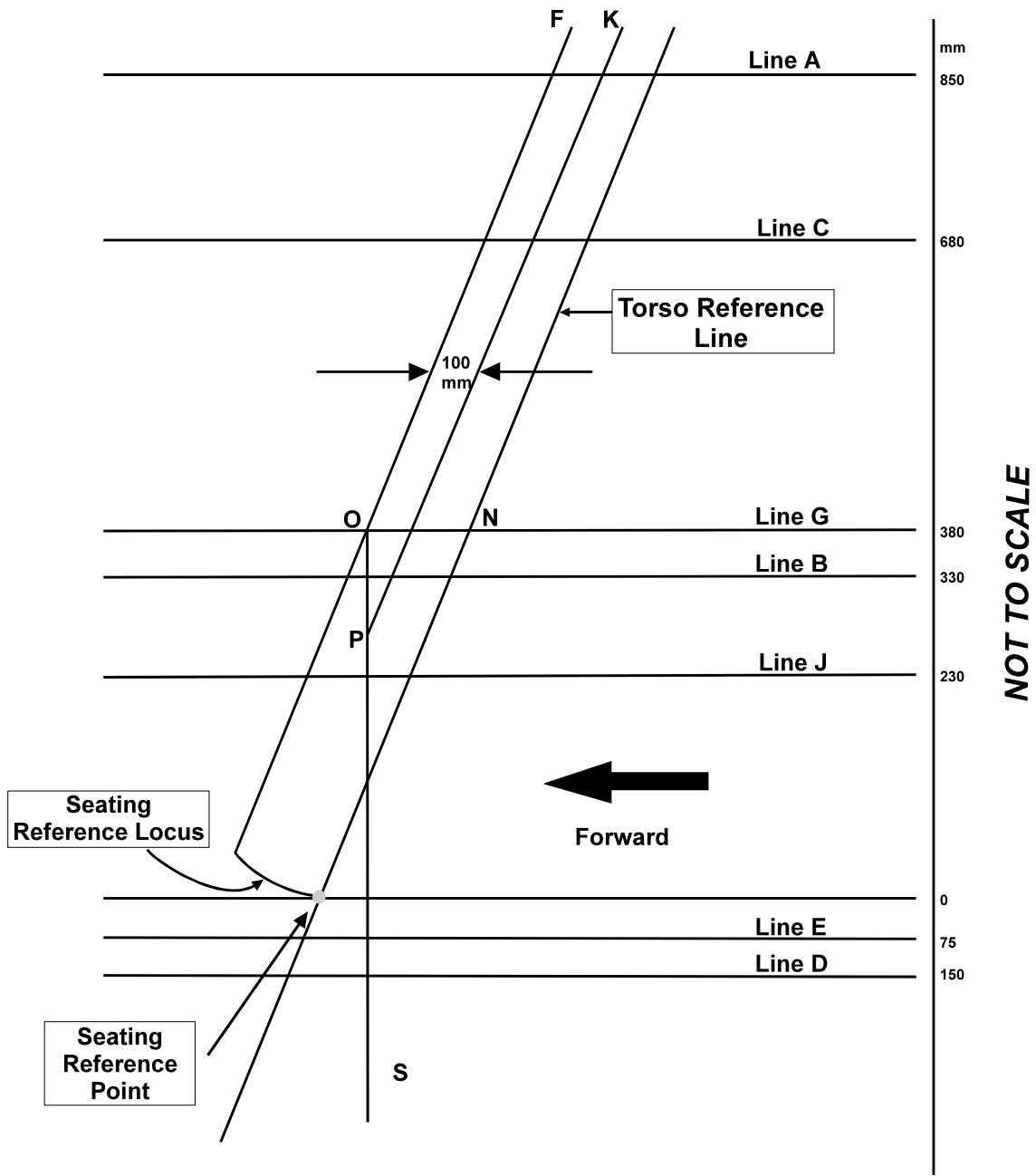

APPENDIX A

REQUIREMENTS FOR TYPE 4N RETRACTORS

The following text is from ECE Regulation 16/04 "Safety Belts", with text not applicable in Australia struck through. The text has been modified slightly, to make it clear that it only applies to *'Type 4N Retractors'*.

6.2.5.3 ~~Emergency locking retractors-~~ *'TYPE 4N RETRACTORS'*

6.2.5.3.1 A ~~n~~-emergency locking *'Type 4N Retractor'*, when tested in accordance with paragraph 7.6.2 must satisfy the conditions below:

4.6.2.5.3.1 FOR AUSTRALIA WHERE A VEHICLE CATEGORY IS REQUIRED, OR A MANUFACTURER ELECTS, TO COMPLY WITH CLAUSES 5.1.1 OR 5.1.2 WHICH INVOKE DYNAMIC TESTING, THE REQUIREMENTS OF CLAUSE 10 MUST BE COMPLIED WITH.

6.2.5.3.1.1 The locking must have occurred when the deceleration of the vehicle reaches ~~0.45 in the case of type 4~~ and 0.85 g^1 in the case of *'Type 4N Retractors'*.

6.2.5.3.1.2 It must not lock for values of acceleration of the strap measured in the direction of the extraction of the strap of less than ~~0.8 g in the case of type 4~~ or less than 1.0 g^1 in the case of *'Type 4N Retractors'*.

6.2.5.3.1.3 It must not lock when its sensing device is tilted 12° or less in any direction from the installation position specified by its manufacturer.

6.2.5.3.1.4 It must lock when its sensing device is tilted by more than ~~27° in the case of type 4~~ or 40° in the case of *'Type 4N Retractors'* in any direction from the installation position specified by its manufacturer.

6.2.5.3.1.5 In cases where the operation of a retractor depends on an external signal or power source, the design must ensure that the retractor locks automatically upon failure or interruption of that signal or power source.

6.2.5.3.2 A retractor with multiple sensitivity must satisfy the specification above, when tested in accordance with paragraph 7.6.2. In addition if one of the sensitivities relates to strap extraction, locking must have occurred at a strap acceleration equal to or more than ~~4.5 g in the case of type 4~~ or more than 2.0 g^1 in the case of *'Type 4N Retractors'*, when measured along the line of the extraction of the strap.

6.2.5.3.3 In the case of the tests mentioned in paragraphs 6.2.5.3.1 and 6.2.5.3.2 above the amount of strap movement which may occur before the retractor locks must not exceed 50 mm starting at the length given in paragraph 7.6.2.1. In the case of the test mentioned in paragraph 6.2.5.3.1.2 above locking must not occur during the 50 mm of strap movement starting at the length given in paragraph 7.6.2.1.

¹ $\text{g} = 9.81\text{ m/s}^2$

6.2.5.3.4 If the retractor is part of a lap belt, the retracting force of the strap must be not less than 0.7 daN when measured in the free length between the dummy and the retractor in accordance with paragraph 7.6.4. If the retractor is part of an upper torso restraint, the retracting force of the strap must be not less than 0.2 daN and not more than 0.7 daN when similarly measured. If the strap passes through a guide or pulley, the retractor force must be measured in the free length between the dummy and the guide or pulley. If the assembly incorporates a device that upon manual or automatic operation prevents the strap from being completely retracted, such a device must not be operated when these requirements are assessed.

6.2.5.3.5 The strap must be withdrawn from the retractor and allowed to retract repeatedly by the method described in paragraph 7.6.1 until 40,000 cycles have been completed. The retractor must then be subjected to the corrosion test given in paragraph 7.2 and after that to the dust test prescribed in paragraph 7.6.3. It must then satisfactorily complete a further 5,000 cycles (making 45,000 in all). After the above tests, the retractor must operate correctly and still meet the requirements of paragraphs 6.2.5.3.1, 6.2.5.3.2, 6.2.5.3.3 and 6.2.5.3.4 above.

7.6 ADDITIONAL TESTS FOR SAFETY BELTS WITH RETRACTORS

7.6.1 Durability of retractor mechanism

7.6.1.1 The strap must be withdrawn and allowed to retract for the required number of cycles at a rate of not more than 30 cycles per minute. In the case of ~~emergency locking~~ 'Type 4N Retractors', a snatch to lock the retractor must be introduced at each fifth cycle. The snatches must occur in equal numbers at each of five different extractors, namely, 90, 80, 75, 70 and 65 per cent of the total length of the strap remaining wound on the retractor. However, where more than 900 mm is provided the above percentages must be related to the final 900 mm of strap which can be withdrawn from the retractor.

7.6.1.2 A suitable apparatus for the tests specified in paragraph 7.6.1.1 above is shown in annex 3 ~~to this Regulation~~.

7.6.2 Locking of 'Type 4N Retractors'

7.6.2.1 The retractor must be tested once for locking when the strap has been unwound to full length less 300 ± 3 mm.

7.6.2.1.1 In the case of a retractor actuated by strap movement, the extraction must be in the direction in which it normally occurs when the retractor is installed in a vehicle.

7.6.2.1.2 When retractors are being tested for sensitivity to vehicle deceleration they must be tested at the above extraction along two perpendicular axes, which are horizontal if the retractor is installed in a vehicle as specified by the safety belt manufacturer. When this position is not specified, the testing authority must consult the safety belt manufacturer. One of these axes must be in the direction ~~chosen by the technical service conducting the approval test~~ to give the most adverse conditions with respect to actuation of the locking mechanism.

7.6.2.2 A suitable apparatus for the tests specified in paragraph 7.6.2.1 above is described in annex 4 ~~to this Regulation~~. The design of any such test

apparatus must ensure that the required acceleration is given at an average rate of increase of acceleration at least $25 g^1$ per second.

7.6.2.5 To check conformity with the requirements of paragraph 6.2.5.3.1.3 and 6.2.5.3.1.4, the retractor must be mounted on a horizontal table and the table tilted with speed not exceeding 2° per second until locking has occurred. The test must be repeated with tilting in other directions to ensure that the requirements are fulfilled.

7.6.3 Dust resistance

7.6.3.1 The retractor must be positioned in a test chamber as described in annex 5 to this Regulation. It must be mounted in an orientation similar to that in which it is mounted in the vehicle. The test chamber must contain dust as specified in paragraph 7.6.3.2 below. A length of 500 mm of the strap must be extracted from the retractor and kept extracted, except that it must be subjected to ten complete cycles of retraction and withdrawal within one or two minutes after each agitation of the dust. For a period of five hours, the dust must be agitated every twenty minutes for five seconds by compressed air free of oil and moisture at a gauge pressure of $5.5 \times 10^5 \pm 0.5 \times 10^5$ Pa entering through an orifice, 1.5 ± 0.1 mm in diameter.

7.6.3.2 The dust used in the test described in paragraph 7.6.3.1 above must consist of about 1 kg of dry quartz. The particle size distribution is as follows:

- (a) passing 150 μm aperture, 104 μm wire diameter: 99 to 100 per cent;
- (b) passing 105 μm aperture, 64 μm wire diameter: 76 to 86 per cent;
- (c) passing 75 μm aperture, 52 μm wire diameter: 60 to 70 per cent.

7.6.4 Retracting force

7.6.4.1 ~~withdrawal and~~ retracting force must be measured with the safety belt assembly fitted to a dummy as for the dynamic test ~~prescribed in paragraph 7.7~~. The strap tension must be measured at the point of contact with (but just clear of) the dummy while the strap is being retracted at the approximate rate of 0.6 metres per minute.

¹ $g = 9.81 \text{ m/s}^2$

Annex 3

DIAGRAM OF AN APPARATUS TO TEST DURABILITY OF RETRACTOR MECHANISM

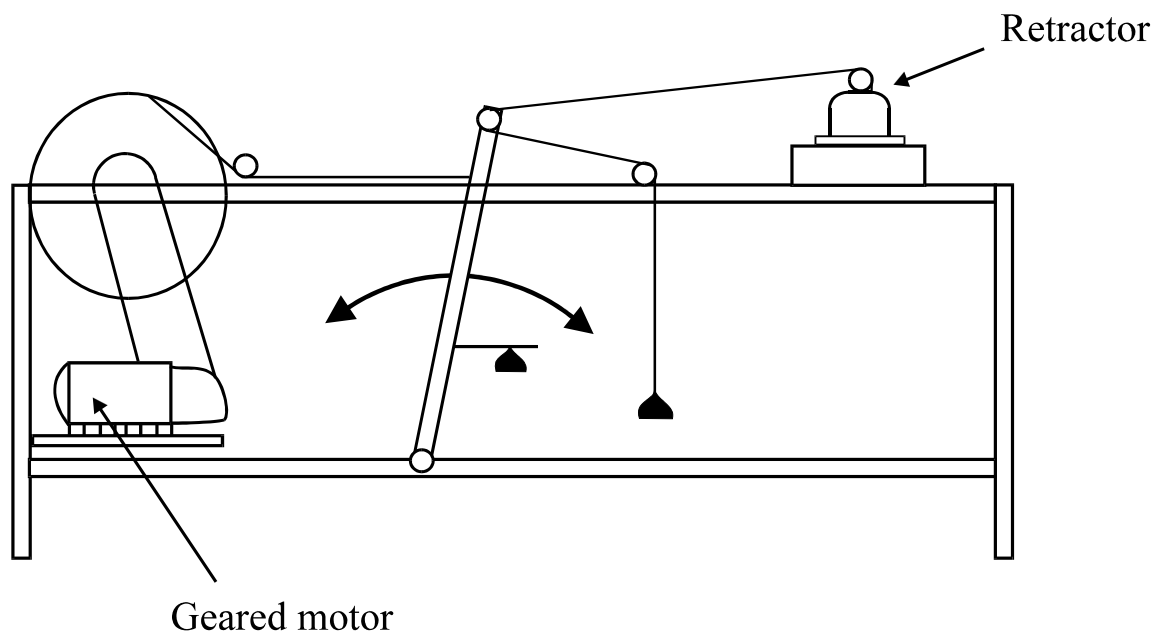

Annex 4

DIAGRAM OF AN APPARATUS TO TEST LOCKING OF EMERGENCY LOCKING 'TYPE 4N RETRACTORS'

A suitable apparatus is illustrated in the figure and consists of a motor-driven cam, the follower of which is attached by wires to a small trolley mounted on a track. The cam design and motor speed combination is such as to give the required acceleration at a rate of increase of acceleration as specified in paragraph 7.6.2.2 of this Regulation Appendix A and the stroke is arranged to be in excess of the maximum permitted webbing movement before locking.

On the trolley a carrier is mounted which can be swivelled to enable the retractor to be mounted in varying positions relative to the direction of movement of the trolley.

When testing retractors for sensitivity to strap movement the retractor is mounted on a suitable fixed bracket and the strap is attached to the trolley.

When carrying out the above tests any brackets, etc. supplied by the manufacturer or his accredited representative shall be incorporated in the test installation to simulate as closely as possible the intended installation in a vehicle.

Any additional brackets, etc. that may be required to simulate the installation as intended in the vehicle shall be provided by the manufacturer or his accredited representative.

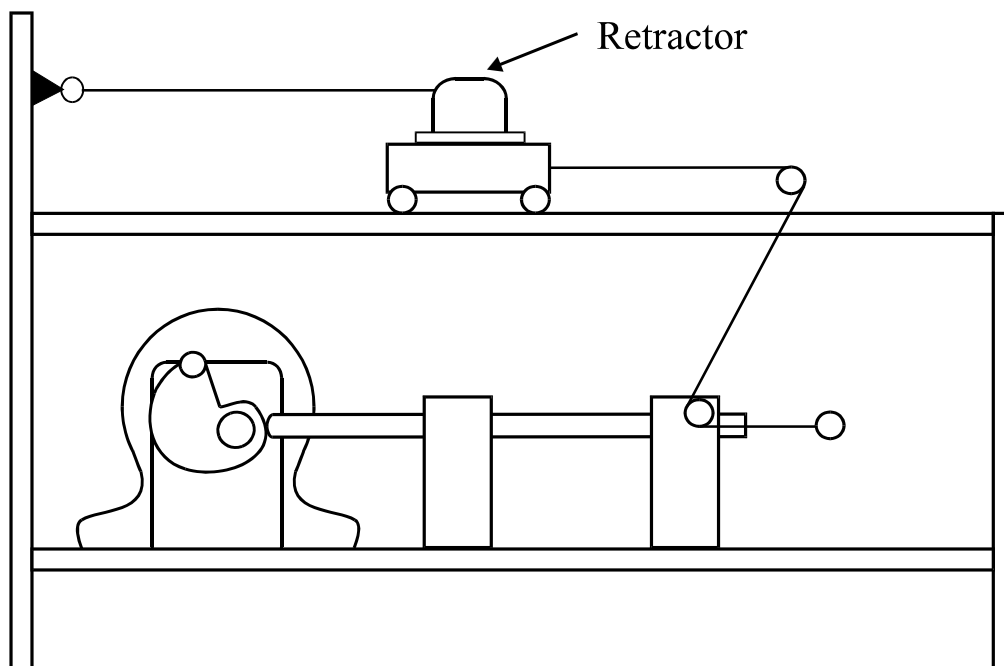

Annex 5 DIAGRAM OF AN APARATUS FOR DUST-RESISTANCE TEST

