



Vehicle Standard (Australian Design Rule 73/00 – Offset Frontal Impact Occupant Protection) 2005

I, JAMES ERIC LLOYD, Minister for Local Government, Territories and Roads,
determine this vehicle standard under subsection 7 (1) of the *Motor Vehicle Standards
Act 1989*.

Dated 29th November 2005

[SIGNED]

James Eric Lloyd
Minister for Local Government, Territories and Roads

CONTENTS

1.	LEGISLATIVE PROVISIONS.....	3
1.1	NAME OF STANDARD	3
1.2	COMMENCEMENT.....	3
1.3	REPEAL.....	3
2.	SCOPE.....	3
3.	APPLICABILITY AND IMPLEMENTATION.....	3
4.	DEFINITIONS	4
5.	REQUIREMENTS	4
6.	ALTERNATIVE STANDARDS	5
	APPENDIX A	6

1. LEGISLATIVE PROVISIONS

1.1 NAME OF STANDARD

- 1.1.1 This Standard is the Vehicle Standard (Australian Design Rule 73/00 – Offset Frontal Impact Occupant Protection) 2005.
- 1.1.2 This Standard may also be cited as Australian Design Rule 73/00 — Offset Frontal Impact Occupant Protection.

1.2 COMMENCEMENT

- 1.2.1 This Standard commences on the day after it is registered.

1.3 REPEAL

- 1.3.1 This Standard repeals each vehicle standard with the name Australian Design Rule 73/00 — Offset Frontal Impact Occupant Protection that is:
 - (a) made under section 7 of the Motor Vehicles Standard Act 1989; and
 - (b) in force at the commencement of this Standard.
- 1.3.2 This Standard also repeals each instrument made under section 7 of the Motor Vehicles Standard Act 1989 that creates a vehicle standard with the name Australian Design Rule 73/00 — Offset Frontal Impact Occupant Protection, if there are no other vehicle standards created by that instrument, or amendments to vehicle standards made by that instrument, that are still in force at the commencement of this Standard.

2. SCOPE

The function of this national standard is to specify crashworthiness requirements in terms of forces and accelerations measured by anthropomorphic dummies so as to minimise the likelihood of injury to the occupants in offset frontal impacts.

3. APPLICABILITY AND IMPLEMENTATION

3.1. Applicability Summary

- 3.1.1. This ADR applies to the design and construction of vehicles as required by clauses 3.1.2 and 3.1.3 and set out in clause 3.2.
- 3.1.2. This rule is binding:
 - (a) from 1 January 2000 on all new model MA category vehicles; and with a *Gross Vehicle Mass* of less than 2.5 tonnes.
 - (b) from 1 January 2004 on all MA category vehicles with a *Gross Vehicle Mass* of less than 2.5 tonnes.
- 3.1.3. For the purposes of clause 3.1.2, a “new model” MA vehicle is a vehicle model first produced with a ‘*Date of Manufacture*’ on or after 1 January 2000.

3.2. Applicability Table

Vehicle Category	ADR Category Code	UNECE Category Code	Manufactured on or After	Acceptable Prior Rules
Moped 2 wheels	LA	L1	N/A	
Moped 3 wheels	LB	L2	N/A	
Motor cycle	LC	L3	N/A	
Motor cycle and sidecar	LD	L4	N/A	
Motor tricycle	LE	L5	N/A	
Passenger car	MA	M1	1 Jan 2000*	Nil
Forward-control passenger vehicle	MB	M1	N/A	
Off-road passenger vehicle	MC	M1	N/A	
Light omnibus	MD	M2	N/A	
Heavy omnibus	ME	M3	N/A	
Light goods vehicle	NA	N1	N/A	
Medium goods vehicle	NB	N2	N/A	
Heavy goods vehicle	NC	N3	N/A	
Very light trailer	TA	O1	N/A	
Light trailer	TB	O2	N/A	
Medium trailer	TC	O3	N/A	
Heavy trailer	TD	O4	N/A	

* See clause 3.1.2 and 3.1.3.

4. DEFINITIONS

4.1. Refer to Vehicle Standard (Australian Design Rule Definitions and Vehicle Categories) 2005.

5. REQUIREMENTS

5.1. Vehicles must comply with the technical requirements from ECE R 94/01 - "UNIFORM PROVISIONS CONCERNING THE APPROVAL OF VEHICLES WITH REGARD TO THE PROTECTION OF THE OCCUPANTS IN THE EVENT OF A FRONTAL COLLISION".

5.2. Appendix A is an extract from ECE R 94/01 - "UNIFORM PROVISIONS CONCERNING THE APPROVAL OF VEHICLES WITH REGARD TO THE PROTECTION OF THE OCCUPANTS IN THE EVENT OF A FRONTAL COLLISION". The document has had administrative provisions not relevant to this national standard either deleted or struck out. In the case of deletion of whole parts or annexes, that part will have the words "[NOT APPLICABLE]" placed beside its title.

5.3. Where ECE R94/01 references ECE R16 and/or ECE R14 compliance may be demonstrated with ADRs 4/xx, 3/xx and 5/xx respectively.

6. ALTERNATIVE STANDARDS

- 6.1. The technical requirements of United Nations –Economic Commission for Europe (UN ECE) Regulation No. 94 UNIFORM PROVISIONS CONCERNING THE APPROVAL OF VEHICLES WITH REGARD TO THE PROTECTION OF THE OCCUPANTS IN THE EVENT OF A FRONTAL COLLISION, incorporating the 01 series of amendments are deemed to be equivalent to the technical requirements of this national standard.

APPENDIX A

Regulation No. 94

AGREEMENT

**CONCERNING THE ADOPTION OF UNIFORM TECHNICAL PRESCRIPTIONS
FOR WHEELED VEHICLES, EQUIPMENT AND PARTS WHICH CAN BE FITTED
AND/OR BE USED ON WHEELED VEHICLES AND THE CONDITIONS FOR
RECIPROCAL RECOGNITION OF APPROVALS GRANTED ON THE BASIS OF
THESE PRESCRIPTIONS ^{*/}**

Addendum 93: Regulation No. 94

Incorporating the 01 series of amendments

Date of entry into force: 1 October 1998

**UNIFORM PROVISIONS CONCERNING THE APPROVAL OF VEHICLES
WITH REGARD TO THE PROTECTION OF THE OCCUPANTS IN THE
EVENT OF A FRONTAL COLLISION**



UNITED NATIONS

^{*/} Former title of Agreement:

Agreement Concerning the Adoption of Uniform Conditions of Approval and Reciprocal Recognition of Approval for Motor Vehicle Equipment and Parts, done at Geneva on 20 March 1958.

Regulation No. 94

UNIFORM PROVISIONS CONCERNING THE APPROVAL OF VEHICLES WITH
REGARD TO THE PROTECTION OF THE OCCUPANTS IN THE EVENT OF A
FRONTAL COLLISION

CONTENTS

REGULATION

1.	Scope	[Not Applicable]
2.	Definitions	
3.	Application for approval	[Not Applicable]
4.	Approval	[Not Applicable]
5.	Specifications	
6.	Instructions for users of vehicles equipped with airbags	
7.	Modification and extension of approval of the vehicle type	[Not Applicable]
8.	Conformity of production	[Not Applicable]
9.	Penalties for non-conformity of production	[Not Applicable]
10.	Production definitely discontinued	[Not Applicable]
11.	Transitional provisions	[Not Applicable]
12.	Names and addresses of technical services responsible for conducting approval tests, and of administrative departments	[Not Applicable]

ANNEXES

Annex 1	Communication	[Not Applicable]
Annex 2	Arrangements of the approval mark	[Not Applicable]
Annex 3	Test procedure	
Annex 4	Determination of performance criteria	
Annex 5	Arrangement and installation of dummies and adjustment of restraint systems	
Annex 6	determining the "h" point and the actual torso angle for seating positions in motor vehicles	Procedure for
Annex 7	Test procedure with trolley	
Annex 8	Technique of measurement in measurement tests: Instrumentation	
Annex 9	Definition of deformable barrier	
Annex 10	Certification procedure for the dummy lower leg and foot	

1. SCOPE [NOT APPLICABLE]

2. DEFINITIONS

For the purposes of this Regulation:

- 2.1. "Protective system", means interior fittings and devices intended to restrain the occupants and contribute towards ensuring compliance with the requirements set out in paragraph 5 below;
- 2.2. "Type of protective system", means a category of protective devices which do not differ in such essential respects as:
 - Their technology;
 - Their geometry;
 - Their constituent materials;
- 2.3. "Vehicle width" means the distance between two planes parallel to the longitudinal median plane (of the vehicle) and touching the vehicle on either side of the said plane but excluding the rear-view mirrors, side marker lamps, tyre pressure indicators, direction indicator lamps, position lamps, flexible mud-guards and the deflected part of the tyre side-walls immediately above the point of contact with the ground;
- 2.4. "Overlap" means the percentage of the vehicle width directly inline with the barrier face;
- 2.5. "Deformable barrier face" means a crushable section mounted on the front of a rigid block;
- 2.6. "Vehicle type", means a category of power-driven vehicles which do not differ in such essential respects as:
 - 2.6.1. The length and width of the vehicle, in so far as they have a negative effect on the results of the impact test prescribed in this Regulation,
 - 2.6.2. The structure, dimensions, lines and materials of the part of the vehicle forward of the transverse plane through the "R" point of the driver's seat, in so far as they have a negative effect on the results of the impact test prescribed in this Regulation,
 - 2.6.3. The lines and inside dimensions of the passenger compartment and the type of protective system, in so far as they have an negative effect on the results of the impact test prescribed in this Regulation,
 - 2.6.4. The siting (front, rear or centre) and the orientation (transversal or longitudinal) of the engine,
 - 2.6.5. The unladen mass, in so far as there is a negative effect on the result of the impact test prescribed in this Regulation,
 - 2.6.6. The optional arrangements or fittings provided by the manufacturer, in so far as they have a negative effect on the result of the impact test prescribed in this Regulation,
- 2.7. "Passenger compartment", means the space for occupant accommodation, bounded by the roof, floor, side walls, doors, outside glazing and front

bulkhead and the plane of the rear compartment bulkhead or the plane of the rear-seat back support;

- 2.8. "R point", means a reference point defined for each seat by the manufacturer in relation to the vehicle's structure, as indicated in annex 6;
- 2.9. "H" point means, a reference point determined for each seat by the testing service responsible for approval, in accordance with the procedure described in annex 6;
- 2.10. "Unladen kerb mass", means the mass of the vehicle in running order, unoccupied and unladen but complete with fuel, coolant, lubricant, tools and a spare wheel (if these are provided as standard equipment by the vehicle manufacturer).
- 2.11. "Airbag " means a device installed to supplement safety belts and restraint systems in power-driven vehicles, i.e. systems which, in the event of a severe impact affecting the vehicle, automatically deploy a flexible structure intended to limit, by compression of the gas contained within it, the gravity of the contacts of one or more parts of the body of an occupant of the vehicle with the interior of the passenger compartment.
- 2.12. "Passenger airbag" means an airbag assembly intended to protect occupant(s) in seats other than the driver's in the event of a frontal collision.
- 2.13. "Child restraint" means an arrangement of components which may comprise a combination of straps or flexible components with a securing buckle, adjusting devices, attachments, and in some cases a supplementary chair and/or an impact shield, capable of being anchored to a power driven vehicle. It is so designed as to diminish the risk of injury to the wearer, in the event of a collision or of abrupt deceleration of the vehicle by limiting the mobility of the wearer's body.
- 2.14. "Rearward-facing" means facing in the direction opposite to the normal direction of travel of the vehicle.

3. APPLICATION FOR APPROVAL [NOT APPLICABLE]

4. APPROVAL [NOT APPLICABLE]

5. SPECIFICATIONS

5.1. General specifications applicable to all tests

5.1.1. The "H" point for each seat shall be determined in accordance with the procedure described in annex 6.

5.1.2. When the protective system for the front seating positions includes belts, the belt components shall meet the requirements of Regulation No. 16.

5.1.3. Seating positions where a dummy is installed and the protective system includes belts, shall be provided with anchorage points conforming to Regulation No. 14.

5.2. Specifications

The test of the vehicle carried out in accordance with the method described in annex 3 shall be considered satisfactory if all the conditions set out in paragraphs 5.2.1. to 5.2.6. below are all satisfied at the same time.

- 5.2.1. The performance criteria recorded, in accordance with annex 8, on the dummies in the front outboard seats shall meet the following conditions:
- 5.2.1.1. The head performance criterion (HPC) shall not exceed 1000 and the resultant head acceleration shall not exceed 80 g for more than 3 ms. The latter shall be calculated cumulatively, excluding rebound movement of the head;
- 5.2.1.2. The neck injury criteria (NIC) shall not exceed the values shown in Figures 1 and 2^{3/};

Figure 1
 Neck tension criterion

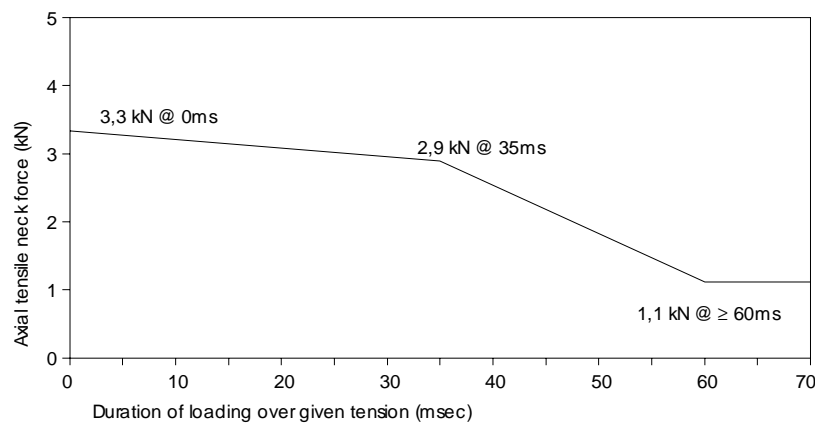
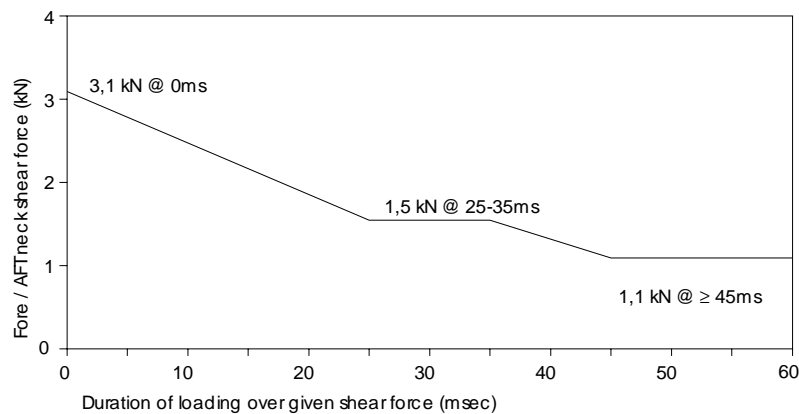

Figure 2
 Neck shear criterion



- 5.2.1.3. The neck bending moment about the y axis shall not exceed 57 Nm in extension^{3/};
- 5.2.1.4. The thorax compression criterion (ThCC) shall not exceed 50 mm;
- 5.2.1.5. The viscous criterion (V * C) for the thorax shall not exceed 1,0 m/s;

^{3/} Until 1 October 1998 the values obtained for the neck shall not be pass/fail criteria for the purposes of granting approval. The results obtained shall be recorded in the test report and be collected by the approval authority. After this date, the values specified in this paragraph shall apply as pass/fail criteria unless or until alternative values are adopted.

- 5.2.1.6. The femur force criterion (FFC) shall not exceed the force-time performance criterion shown in Figure 3;

Figure 3

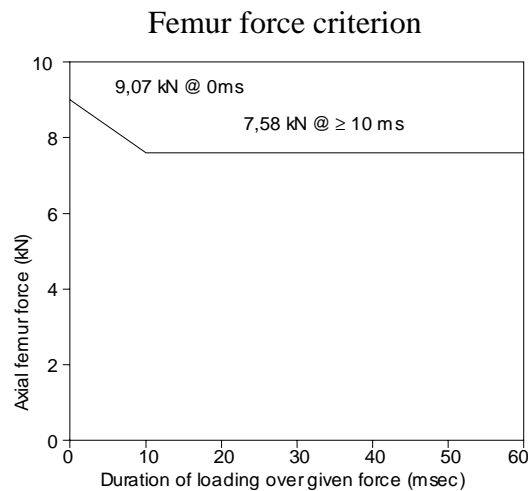

- 5.2.1.7. The tibia compression force criterion (TCFC) shall not exceed 8 kN;
- 5.2.1.8. The tibia index (TI), measured at the top and bottom of each tibia, shall not exceed 1,3 at either location;
- 5.2.1.9. The movement of the sliding knee joints shall not exceed 15 mm.
- 5.2.2. Residual steering wheel displacement, measured at the centre of the steering wheel hub, shall not exceed 80 mm in the upwards vertical direction and 100 mm in the rearward horizontal direction.
- 5.2.3. During the test no door shall open;
- 5.2.4. During the test no locking of the locking systems of the front doors shall occur;
- 5.2.5. After the impact, it shall be possible, without the use of tools except for those necessary to support the weight of the dummy:
- 5.2.5.1. To open at least one door, if there is one, per row of seats and, where there is no such door, to move the seats or tilt their backrests as necessary to allow the evacuation of all the occupants; this is, however, only applicable to vehicles having a roof of rigid construction;
- 5.2.5.2. To release the dummies from their restraint system which, locked, shall be capable of being released by a maximum force of 60 N on the centre of the release control;
- 5.2.5.3. To remove the dummies from the vehicle without adjustment of the seats.
- 5.2.6. In the case of a vehicle propelled by liquid fuel, no more than slight leakage of liquid from the fuel-feed installation shall occur on collision;
- 5.2.7. If there is continuous leakage of liquid from the fuel-feed installation after the collision, the rate of leakage shall not exceed 30 g/min; if the liquid from the fuel-feed system mixes with liquids from the other systems and the various liquids cannot easily be separated and identified, all the liquids collected shall be taken into account in evaluating the continuous leakage.

6. INSTRUCTIONS FOR USERS OF VEHICLES EQUIPPED WITH AIRBAGS

- 6.1. The vehicle shall carry information to the effect that it is equipped with airbags for seats.
- 6.1.1. For a vehicle fitted with an airbag assembly intended to protect the driver, this information shall consist of the inscription "AIRBAG" located in the interior of the circumference of the steering wheel; this inscription shall be durably affixed and easily visible.
- 6.1.2. For a vehicle fitted with a passenger airbag intended to protect front seat occupants other than the driver, this information shall consist of the warning label described in paragraph 6.2. below.
- 6.2. A vehicle fitted with one or more passenger airbags shall carry information about the extreme hazard associated with the use of rearward-facing child restraints on seats equipped with airbag assemblies.
- 6.2.1 As a minimum, this information shall consist of a pictogram label as indicated below.

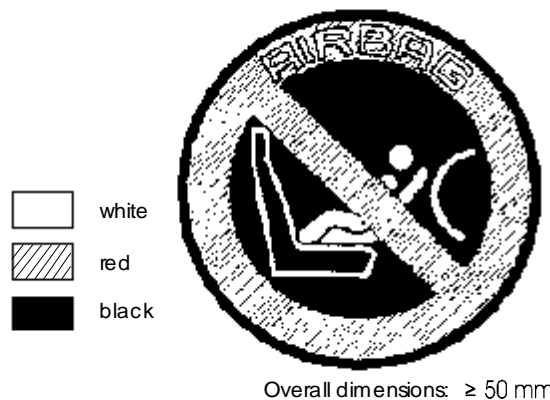

- 6.2.2. The warning label shall be durably affixed and located such that it is easily visible in front of a person about to install a rearward-facing child restraint on the seat in question. A permanent reference should be visible at all times, in case the warning is not visible when the door is closed.

This requirement does not apply to those seats equipped with a device which automatically deactivates the airbag assembly when a rearward-facing child restraint is installed.

- 6.2.3. Detailed information, making reference to the label, shall be contained in the owner's manual of the vehicle; as a minimum the following text in an official ECE language, supplemented by the corresponding text in the language of the country where the vehicle is to be registered, must be included:

"Extreme Hazard! Do not use a rearward facing child restraint on a seat protected by an airbag in front of it!"

The text shall be accompanied by the pictogram mounted on the vehicle.

7. **MODIFICATION AND EXTENSION OF APPROVAL OF THE VEHICLE TYPE** [NOT APPLICABLE]
8. **CONFORMITY OF PRODUCTION** [NOT APPLICABLE]
9. **PENALTIES FOR NON-CONFORMITY OF PRODUCTION** [NOT APPLICABLE]
10. **PRODUCTION DEFINITELY DISCONTINUED** [NOT APPLICABLE]
11. **TRANSITIONAL PROVISIONS** [NOT APPLICABLE]
12. **NAMES AND ADDRESSES OF TECHNICAL SERVICES RESPONSIBLE FOR CONDUCTING APPROVAL TESTS, AND OF ADMINISTRATIVE DEPARTMENTS** [NOT APPLICABLE]

**Annex 1
COMMUNICATION**

[NOT APPLICABLE]

**Annex 2
ARRANGEMENTS OF THE APPROVAL MARK**

[NOT APPLICABLE]

**Annex 3
TEST PROCEDURE**

1. INSTALLATION AND PREPARATION OF THE VEHICLE

1.1. Testing ground

The test area shall be large enough to accommodate the run-up track, barrier and technical installations necessary for the test. The last part of the track, for at least 5 m before the barrier, shall be horizontal, flat and smooth.

1.2. Barrier

The front face of the barrier consists of a deformable structure as defined in annex 9 of this Regulation. The front face of the deformable structure is perpendicular within $\pm 1^\circ$ to the direction of travel of the test vehicle. The barrier is secured to a mass of not less than 7×10^4 kg, the front face of which is vertical within $\pm 1^\circ$. The mass is anchored in the ground or placed on the ground with, if necessary, additional arresting devices to restrict its movement.

1.3. Orientation of the barrier

The orientation of the barrier is such that the first contact of the vehicle with the barrier is on the steering-column side. Where there is a choice between carrying out the test with a right-hand or left-hand drive vehicle, the test shall be carried out with the less favourable hand of drive as determined by the technical service responsible for the tests.

1.3.1. Alignment of the vehicle to the barrier.

The vehicle shall overlap the barrier face by 40 per cent ± 20 mm.

1.4. State of vehicle

1.4.1. General specification

The test vehicle shall be representative of the series production, shall include all the equipment normally fitted and shall be in normal running order. Some components may be replaced by equivalent masses where this substitution clearly has no noticeable effect on the results measured under paragraph 6.

1.4.2. Mass of vehicle

1.4.2.1. For the test, the mass of the vehicle submitted shall be the unladen kerb mass;

- 1.4.2.2. The fuel tank shall be filled with water to mass equal to 90 per cent of the mass of a full as specified by the manufacturer with a tolerance of ± 1 per cent ;
- 1.4.2.3. All the other systems (brake, cooling, ...) may be empty in this case, the mass of the liquids shall be carefully compensated;
- 1.4.2.4. If the mass of the measuring apparatus on board the vehicle exceeds the 25 kg allowed, it may be compensated by reductions which have no noticeable effect on the results measured under paragraph 6 below.
- 1.4.2.5. The mass of the measuring apparatus shall not change each axle reference load by more than 5%, each variation not exceeding 20 kg
- 1.4.2.6. The mass of the vehicle resulting from the provisions of paragraph 1.4.2.1. above shall be indicated in the report.
- 1.4.3. Passenger compartment adjustments
- 1.4.3.1. Position of steering wheel
- The steering wheel, if adjustable, shall be placed in the normal position indicated by the manufacturer or, failing that, midway between the limits of its range(s) of adjustment. At the end of propelled travel, the steering wheel shall be left free, with its spokes in the position which according to the manufacturer corresponds to straight-ahead travel of the vehicle.
- 1.4.3.2. Glazing
- The movable glazing of the vehicle shall be in the closed position. For test measurement purposes and in agreement with the manufacturer, it may be lowered, provided that the position of the operating handle corresponds to the closed position.
- 1.4.3.3. Gear-change lever
- The gear-change lever shall be in the neutral position.
- 1.4.3.4. Pedals
- The pedals shall be in their normal position of rest. If adjustable, they shall be set in their mid position unless another position is specified by the manufacturer.
- 1.4.3.5. Doors
- The doors shall be closed but not locked.
- 1.4.3.6. Opening roof
- If an opening or removable roof is fitted, it shall be in place and in the closed position. For test measurement purposes and in agreement with the manufacturer, it may be open.
- 1.4.3.7. Sun-visor
- The sun-visors shall be in the stowed position.
- 1.4.3.8. Rear-view mirror
- The interior rear-view mirror shall be in the normal position of use.
-

1.4.3.9. Arm-rests

Arm-rests at the front and rear, if movable, shall be in the lowered position, unless this is prevented by the position of the dummies in the vehicles.

1.4.3.10. Head restraints

Head restraints adjustable for height shall be in their uppermost position.

1.4.3.11. Seats

1.4.3.11.1. Position of front seats

Seats adjustable longitudinally shall be placed so that their "H" point, determined in accordance with the procedure set out in annex 6 is in the middle position of travel or in the nearest locking position thereto, and at the height position defined by the manufacturer (if independently adjustable for height). In the case of a bench seat, the reference shall be to the "H" point of the driver's place.

1.4.3.11.2. Position of the front seat-backs

If adjustable, the seat-backs shall be adjusted so that the resulting inclination of the torso of the dummy is as close as possible to that recommended by the manufacturer for normal use or, in the absence of any particular recommendation by the manufacturer, to 25° towards the rear from the vertical.

1.4.3.11.3. Rear seats

If adjustable, the rear seats or rear bench seats shall be placed in the rearmost position.

2. DUMMIES

2.1. Front seats

2.1.1. A dummy corresponding to the specifications for Hybrid III ^{1/-7} fitted with a 45° ankle and meeting the specifications for its adjustment shall be installed in each of the front outboard seats in accordance with the conditions set out in annex 8. The ankle of the dummy shall be certified in accordance with the procedures in annex 10.

2.1.2. The car will be tested with restraint systems, as provided by the manufacturer.

3. PROPULSION AND COURSE OF VEHICLE

3.1. The vehicle shall not be propelled by its own engine or by any other propelling device;

3.2. At the moment of impact the vehicle shall no longer be subject to the action of any additional steering or propelling device.

3.3. The course of the vehicle shall be such that it satisfies the requirements of paragraphs 1.2. and 1.3.1.

^{1/-7} The technical specifications and detailed drawings of Hybrid III, corresponding to the principle dimensions of a fiftieth percentile male of the United States of America, and the specifications for its adjustment for this test are deposited with the Secretary-General of the United Nations and may be consulted on request at the secretariat of the Economic Commission for Europe, Palates of Nations, Geneva, Switzerland.

4. TEST SPEED

Vehicle speed at the moment of impact shall be 56 -0/ +1 km/h. However, if the test was performed at a higher impact speed and the vehicle met the requirements, the test shall be considered satisfactory.

5. MEASUREMENTS TO BE MADE ON DUMMY IN FRONT SEATS

5.1. All the measurements necessary for the verification of the performance criteria shall be made with measurement systems corresponding to the specifications of annex 8.

5.2. The different parameters shall be recorded through independent data channels of the following CFC (Channel Frequency Class):

5.2.1. Measurements in the head of the dummy

The acceleration (a) referring to the centre of gravity is calculated from the triaxial components of the acceleration measured with a CFC of 1000.

5.2.2. Measurements in the neck of the dummy

5.2.2.1. The axial tensile force and the fore/aft shear force at the neck/head interface are measured with a CFC of 1000.

5.2.2.2. The bending moment about a lateral axis at the neck/head interface are measured with a CFC of 600.

5.2.3. Measurements in the thorax of the dummy

The chest deflection between the sternum and the spine is measured with a CFC of 180.

5.2.4. Measurements in the femur and tibia of the dummy

5.2.4.1. The axial compressive force and the bending moments are measured with a CFC of 600.

5.2.4.2. The displacement of the tibia with respect to the femur is measured at the knee sliding joint with a CFC of 180.

6. MEASUREMENTS TO BE MADE ON THE VEHICLE

6.1. To enable the simplified test described in annex 7 to be carried out, the deceleration time history of the structure shall be determined on the basis of the value of the longitudinal accelerometers at the base of the "B" pillar on the struck side of the vehicle with a CFC of 180 by means of data channels corresponding to the requirements set out in annex 8;

6.2. The speed time history which will be used in the test procedure described in annex 7 shall be obtained from the longitudinal accelerometer at the "B" pillar on the struck side.

Annex 4

DETERMINATION OF PERFORMANCE CRITERIA

1. HEAD PERFORMANCE CRITERION (HPC)

- 1.1. This criterion is considered to be satisfied when, during the test, there is no contact between the head and any vehicle component.
- 1.2. If that is not the case, a calculation of the value of HPC is made, on the basis of the acceleration (a), measured according to paragraph 5.2.1. of annex 3 by the following expression:

$$\text{HPC} = (t_2 - t_1) \left[\frac{1}{t_2 - t_1} \int_{t_1}^{t_2} a dt \right]^{2.5}$$

in which:

- 1.2.1. the term 'a' is the resultant acceleration measured according to paragraph 5.2.1. of annex 3 and is measured in units of gravity, g (1 g = 9,81 m/s²)
- 1.2.2. if the beginning of the head contact can be determined satisfactorily, t₁ and t₂ are the two time instants, expressed in seconds, defining an interval between the beginning of the head contact and the end of the recording for which the value of HPC is maximum;
- 1.2.3. if the beginning of the head contact cannot be determined, t₁ and t₂ are the two time instants, expressed in seconds, defining a time interval between the beginning and the end of the recording for which the value of HPC is maximum.
- 1.2.4. Values of HPC for which the time interval (t₁ - t₂) is greater than 36 ms are ignored for the purposes of calculating the maximum value.
- 1.3. The value of the resultant head acceleration during forward impact which is exceeded for 3 ms cumulatively is calculated from the resultant head acceleration measured according to paragraph 5.2.1. of annex 3.

2. NECK INJURY CRITERIA (NIC)

- 2.1. These criteria are determined by the compressive axial force, the axial tensile force and the fore/aft shear forces at the head/neck interface, expressed in kN and measured according to paragraph 5.2.2. of annex 3 and by the duration of these forces expressed in ms.
- 2.2. The neck bending moment criterion is determined by the bending moment, expressed in Nm, about a lateral axis at the head/neck interface and measured according to paragraph 5.2.2. of annex 3.
- 2.3. The neck flexion bending moment, expressed in Nm, shall be recorded.

3. THORAX COMPRESSION CRITERION (ThCC) AND VISCOUS CRITERION (V * C)

- 3.1. The thorax compression criterion is determined by the absolute value of the thorax deformation, expressed in mm and measured according to paragraph 5.2.3. of annex 3.

3.2. The viscous criterion ($V * C$) is calculated as the instantaneous product of the compression and the rate of deflection of the sternum, measured according to paragraph 6 and also paragraph 5.2.3. of annex 3.

4. FEMUR FORCE CRITERION (FFC)

4.1. This criterion is determined by the compression load expressed in kN, transmitted axially on each femur of the dummy and measured according to paragraph 5.2.4. of annex 3 and by the duration of the compressive load expressed in ms.

5. TIBIA COMPRESSIVE FORCE CRITERION (TCFC) AND TIBIA INDEX (TI)

5.1. The tibia compressive force criterion is determined by the compressive load (F_z) expressed in kN, transmitted axially on each tibia of the dummy and measured according to paragraph 5.2.4. of annex 3.

5.2. The tibia index is calculated on the basis of the bending moments (M_x and M_y) measured according to paragraph 5.1. by the following expression:

where:

$$TI = |M_R / (M_C)_R| + |F_Z / (F_C)_Z|$$

M_X = bending moment about the x axis

M_Y = bending moment about the y axis

$(M_C)_R$ = critical bending moment and shall be taken to be 225 Nm

F_Z = compressive axial force in the z direction

$(F_C)_Z$ = critical compressive force in the z direction and shall be taken to be 35,9 kN and

$$M_R = \sqrt{(M_x)^2 + (M_y)^2}$$

The tibia index is calculated for the top and the bottom of each tibia; however, F_Z may be measured at either location. The value obtained is used for the top and bottom TI calculations. Moments M_X and M_Y are both measured separately at both locations.

6. PROCEDURE FOR CALCULATING THE VISCOUS CRITERIA ($V * C$) FOR HYBRID III DUMMY

6.1. The viscous criterion is calculated as the instantaneous product of the compression and the rate of deflection of the sternum. Both are derived from the measurement of sternum deflection.

6.2. The sternum deflection response is filtered once at CFC 180. The compression at time t is calculated from this filtered signal as:

$$C_{(t)} = \frac{D_{(t)}}{0.229}$$

The sternum deflection velocity at time t is calculated from the filtered deflection as:

$$V(t) = \frac{8 \times (D_{(t+1)} - D_{(t-1)}) - (D_{(t+2)} - D_{(t-2)})}{12\delta t}$$

where $D(t)$ is the deflection at time t in metres and δt is the time interval in seconds between the measurements of deflection. The maximum value of δt shall be $1,25 \times 10^{-4}$ seconds. This calculation procedure is shown diagrammatically below:

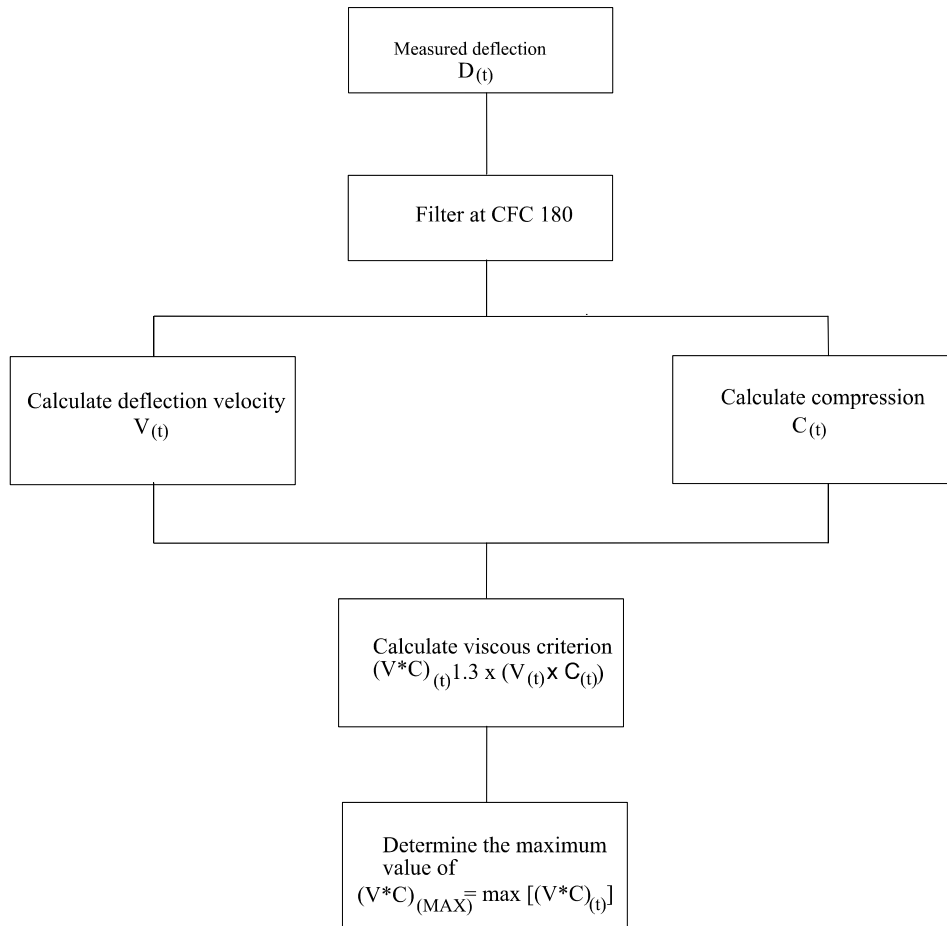

Annex 5
ARRANGEMENT AND INSTALLATION OF DUMMIES AND ADJUSTMENT
OF RESTRAINT SYSTEMS

1. ARRANGEMENT OF DUMMIES

1.1. Separate seats

The plane of symmetry of the dummy shall coincide with the vertical median plane of the seat.

1.2. Front bench seat

1.2.1. Driver

The plane of symmetry of the dummy shall lie in the vertical plane passing through the steering wheel centre and parallel to the longitudinal median plane of the vehicle. If the seating position is determined by the shape of the bench, such seat shall be regarded as a separate seat.

1.2.2. Outer passenger

The plane of symmetry of the dummy shall be symmetrical with that of the driver dummy relative to the longitudinal median plane of the vehicle. If the seating position is determined by the shape of the bench, such seat shall be regarded as a separate seat.

1.3. Bench seat for front passengers (not including driver)

The planes of symmetry of the dummy shall coincide with the median planes of the seating positions defined by the manufacturer.

2. INSTALLATION OF DUMMIES

2.1. Head

The transverse instrumentation platform of the head shall be horizontal within 2.5 °. To level the head of the test dummy in vehicles with upright seats with non-adjustable backs, the following sequences must be followed. First adjust the position of the "H" point within the limits set forth in paragraph 2.4.3.1. below to level the transverse instrumentation platform of the head of the test dummy. If the transverse instrumentation platform of the head is still not level, then adjust the pelvic angle of the test dummy within the limits provided in paragraph 2.4.3.2. below. If the transverse instrumentation platform of the head is still not level, then adjust the neck bracket of the test dummy the minimum amount necessary to ensure that the transverse instrumentation platform of the head is horizontal within 2.5 °.

2.2. Arms

2.2.1. The driver's upper arms shall be adjacent to the torso with the centrelines as close to a vertical plane as possible.

2.2.2. The passenger's upper arms shall be in contact with the seat back and the sides of the torso.

2.3. Hands

2.3.1. The palms of the driver test dummy shall be in contact with the outer part of the steering wheel rim at the rim's horizontal centreline. The thumbs shall be

over the steering wheel rim and shall be lightly taped to the steering wheel rim so that if the hand of the test dummy is pushed upward by a force of not less than 9 N and not more than 22 N, the tape shall release the hand from the steering wheel rim.

2.3.2. The palms of the passenger test dummy shall be in contact with outside of thigh. The little finger shall be in contact with the seat cushion.

2.4. Torso

2.4.1. In vehicles equipped with bench seats, the upper torso of the driver and passenger test dummies shall rest against the seat back. The midsagittal plane of the driver dummy shall be vertical and parallel to the vehicle's longitudinal centreline, and pass through the centre of the steering wheel rim. The midsagittal plane of the passenger dummy shall be vertical and parallel to the vehicle's longitudinal centreline and the same distance from the vehicle's longitudinal centreline as the midsagittal plane of the driver dummy.

2.4.2. In vehicles equipped with individual seat(s), the upper torso of the driver and passenger test dummies shall rest against the seat back. The midsagittal plane of the driver and the passenger dummy shall be vertical and shall coincide with the longitudinal centreline of the individual seat(s).

2.4.3. Lower torso

2.4.3.1. "H" point

The "H" point of the driver and passenger test dummies shall coincide within 13 mm in the vertical dimension and 13 mm in the horizontal dimension with a point 6 mm below the position of the 'H' point determined using the procedure described in annex 6 except that the length of the lower leg and thigh segments of the "H" point machine shall be adjusted to 414 and 401 mm, instead of 432 and 417 mm respectively."

2.4.3.2. Pelvic angle

As determined using the pelvic angle gauge (GM) drawing 78051-532 incorporated by reference in Part 572 which is inserted into the "H" point gauging hole of the dummy, the angle measured from the horizontal on the 76.2 mm (3 inch) flat surface of the gauge shall be 22 1/2 degrees plus or minus 2 1/2 degrees.

2.5. Legs

The upper legs of the driver and passenger test dummies shall rest against the seat cushion to the extent permitted by placement of the feet. The initial distance between the outboard knee clevis flange surface shall be 270 mm \pm 10 mm. To the extent practicable, the left leg of the driver dummy and both legs of the passenger dummy shall be in vertical longitudinal planes. To the extent practicable, the right leg of the driver dummy shall be in a vertical plane. Final adjustment to accommodate placement of feet in accordance with paragraph 2.6. for various passenger compartment configurations is permitted.

2.6. Feet

2.6.1. The right foot of the driver test dummy shall rest on the undepressed accelerator with the rearmost point of the heel on the floor surface in the plane of the pedal. If the foot cannot be placed on the accelerator pedal, it shall be positioned perpendicular to the tibia and placed as far forward as possible in the direction of the centreline of the pedal with the rearmost point of the heel resting on the floor surface. The heel of the left foot shall be placed as far forward as possible and shall rest on the floor pan. The left foot shall be positioned as flat as possible on the toeboard. The longitudinal centreline of the left foot shall be placed as parallel as possible to the longitudinal centreline of the vehicle.

2.6.2. The heels of both feet of the passenger test dummy shall be placed as far forward as possible and shall rest on the floor pan. Both feet shall be positioned as flat as possible on the toeboard. The longitudinal centreline of the feet shall be placed as parallel as possible to the longitudinal centreline of the vehicle.

2.7. The measuring instruments installed shall not in any way affect the movement of the dummy during impact.

2.8. The temperature of the dummies and the system of measuring instruments shall be stabilised before the test and maintained so far as possible within a range between 19 °C and 22 °C.

2.9. Dummy clothing

2.9.1. The instrumented dummies will be clothed in formfitting cotton stretch garments with short sleeves and mid-calf length trousers specified in FMVSS 208, drawings 78051-292 and 293 or their equivalent.

2.9.2. A size 11EE shoe, specified in FMVSS 208, drawings 78501-294 (left) and 78501-295 (right) or their equivalent, will be placed on each foot of the test dummies.

3. ADJUSTMENT OF RESTRAINT SYSTEM

With the test dummy at its designated seating position as specified by the appropriate requirements of paragraphs 2.1. through 2.6., place the belt around the test dummy and fasten the latch. Remove all slack from the lap belt. Pull the upper torso webbing out of the retractor and allow it to retract. Repeat this operation four times. Apply a 9 to 18 N tension load to the lap belt. If the belt system is equipped with a tension-relieving device, introduce the maximum amount of slack into the upper torso belt that is recommended by the manufacturer for normal use in the owner's manual for the vehicle. If the belt system is not equipped with a tension-relieving device, allow the excess webbing in the shoulder belt to be retracted by the retractive force of the retractor.

Annex 6
**PROCEDURE FOR DETERMINING THE "H" POINT AND THE ACTUAL
TORSO ANGLE FOR SEATING POSITIONS IN MOTOR VEHICLES**

1. PURPOSE

The procedure described in this annex is used to establish the "H" point location and the actual torso angle for one or several seating positions in a motor vehicle and to verify the relationship of measured data to design specifications given by the vehicle manufacturer.^{1/-8}

2. DEFINITIONS

For the purposes of this annex:

2.1. "Reference data"

means one or several of the following characteristics of a seating position:

2.1.1. the "H" point and the "R" point and their relationship,

2.1.2. the actual torso angle and the design torso angle and their relationship.

2.2. "Three-dimensional 'H' point machine"

(3-D H machine) means the device used for the determination of "H" points and actual torso angles. This device is described in appendix 1 to this annex;

2.3. "'H' point"

means the pivot centre of the torso and the thigh of the 3-D H machine installed in the vehicle seat in accordance with paragraph 4 below. The "H" point is located in the centre of the centreline of the device which is between the "H" point sight buttons on either side of the 3-D H machine. The "H" point corresponds theoretically to the "R" point (for tolerances see paragraph 3.2.2. below). Once determined in accordance with the procedure described in paragraph 4, the "H" point is considered fixed in relation to the seat-cushion structure and to move with it when the seat is adjusted;

2.4. "'R' point" or "seating reference point"

means a design point defined by the vehicle manufacturer for each seating position and established with respect to the three-dimensional reference system;

2.5. "Torso-line"

means the centreline of the probe of the 3-D H machine with the probe in the fully rearward position;

2.6. "Actual torso angle"

means the angle measured between a vertical line through the "H" point and the torso line using the back angle quadrant on the 3-D H machine. The actual torso angle corresponds theoretically to the design torso angle (for tolerances see paragraph 3.2.2. below):

^{1/-8} In any seating position other than seats where the "H" point cannot be determined using the "Three-Dimensional 'H' point machine" or procedures, the "R" point indicated by the manufacturer may be taken as a reference at the discretion of the competent authority.

- 2.7. "Design torso angle"
means the angle measured between a vertical line through the "R" point and the torso line in a position which corresponds to the design position of the seat-back established by the vehicle manufacturer;
- 2.8. "Centreplane of occupant"
(C/LO) means the median plane of the 3-D H machine positioned in each designated seating position; it is represented by the co-ordinate of the "H" point on the "Y" axis. For individual seats, the centreplane of the seat coincides with the centreplane of the occupant. For other seats, the centreplane of the occupant is specified by the manufacturer;
- 2.9. "Three-dimensional reference system"
means a system as described in appendix 2 to this annex;
- 2.10. "Fiducial marks"
are physical points (holes, surfaces, marks or indentations) on the vehicle body as defined by the manufacturer;
- 2.11. "Vehicle measuring attitude"
means the position of the vehicle as defined by the co-ordinates of fiducial marks in the three-dimensional reference system.

3. REQUIREMENTS

- 3.1. Data presentation
For each seating position where reference data are required in order to demonstrate compliance with the provisions of the present Regulation, all or an appropriate selection of the following data shall be presented in the form indicated in appendix 3 to this annex:
- 3.1.1. the co-ordinates of the "R" point relative to the three-dimensional reference system;
- 3.1.2. the design torso angle;
- 3.1.3. all indications necessary to adjust the seat (if it is adjustable) to the measuring position set out in paragraph 4.3. below.
- 3.2. Relationship between measured data and design specifications
- 3.2.1. The co-ordinates of the "H" point and the value of the actual torso angle obtained by the procedure set out in paragraph 4. below shall be compared, respectively, with the co-ordinates of the "R" point and the value of the design torso angle indicated by the vehicle manufacturer.
- 3.2.2. The relative positions of the "R" point and the "H" point and the relationship between the design torso angle and the actual torso angle shall be considered satisfactory for the seating position in question if the "H" point, as defined by its co-ordinates, lies within a square of 50 mm side length with horizontal and vertical sides whose diagonals intersect at the "R" point, and if the actual torso angle is within 5° of the design torso angle.

- 3.2.3. If these conditions are met, the "R" point and the design torso angle, shall be used to demonstrate compliance with the provisions of this Regulation.
- 3.2.4. If the "H" point or the actual torso angle does not satisfy the requirements of paragraph 3.2.2. above, the "H" point and the actual torso angle shall be determined twice more (three times in all). If the results of two of these three operations satisfy the requirements, the conditions of paragraph 3.2.3. above shall apply.
- 3.2.5. If the results of at least two of the three operations described in paragraph 3.2.4. above do not satisfy the requirements of paragraph 3.2.2. above, or if the verification cannot take place because the vehicle manufacturer has failed to supply information regarding the position of the "R" point or regarding the design torso angle, the centroid of the three measured points or the average of the three measured angles shall be used and be regarded as applicable in all cases where the "R" point or the design torso angle is referred to in this Regulation.

4. PROCEDURE FOR "H" POINT AND ACTUAL TORSO ANGLE DETERMINATION

- 4.1. The vehicle shall be preconditioned at the manufacturer's discretion, at a temperature of $20 \pm 10^{\circ}\text{C}$ to ensure that the seat material reached room temperature. If the seat to be checked has never been sat upon, a 70 to 80 kg person or device shall sit on the seat twice for one minute to flex the cushion and back. At the manufacturer's request, all seat assemblies shall remain unloaded for a minimum period of 30 min prior to installation of the 3-D H machine.
- 4.2. The vehicle shall be at the measuring attitude defined in paragraph 2.11. above.
- 4.3. The seat, if it is adjustable, shall be adjusted first to the rearmost normal driving or riding position, as indicated by the vehicle manufacturer, taking into consideration only the longitudinal adjustment of the seat, excluding seat travel used for purposes other than normal driving or riding positions. Where other modes of seat adjustment exist (vertical, angular, seat-back, etc.) these will then be adjusted to the position specified by the vehicle manufacturer. For suspension seats, the vertical position shall be rigidly fixed corresponding to a normal driving position as specified by the manufacturer.
- 4.4. The area of the seating position contacted by the 3-D H machine shall be covered by a muslin cotton, of sufficient size and appropriate texture, described as a plain cotton fabric having 18.9 threads per cm^2 and weighing 0.228 kg/m^2 or knitted or non-woven fabric having equivalent characteristics. If the test is run on a seat outside the vehicle, the floor on which the seat is placed shall have the same essential characteristics^{2/-9} as the floor of the vehicle in which the seat is intended to be used.
- 4.5. Place the seat and back assembly of the 3-D H machine so that the centre plane of the occupant (C/LO) coincides with the centre plane of the 3-D H

^{2/-9} Tilt angle, height difference with a seat mounting, surface texture, etc.

machine. At the manufacturer's request, the 3-D H machine may be moved inboard with respect to the C/LO if the 3-D H machine is located so far outboard that the seat edge will not permit levelling of the 3-D H machine.

- 4.6. Attach the foot and lower leg assemblies to the seat pan assembly, either individually or by using the T-bar and lower leg assembly. A line through the "H" point sight buttons shall be parallel to the ground and perpendicular to the longitudinal centre plane of the seat.
- 4.7. Adjust the feet and leg positions of the 3-D H machine as follows:
 - 4.7.1. Designated seating position: driver and outside front passenger
 - 4.7.1.1. Both feet and leg assemblies shall be moved forward in such a way that the feet take up natural positions on the floor, between the operating pedals if necessary. Where possible the left foot shall be located approximately the same distance to the left of the centre plane of the 3-D H machine as the right foot is to the right. The spirit level verifying the transverse orientation of the 3-D H machine is brought to the horizontal by readjustment of the seat pan if necessary, or by adjusting the leg and foot assemblies towards the rear. The line passing through the "H" point sight buttons shall be maintained perpendicular to the longitudinal centre plane of the seat.
 - 4.7.1.2. If the left leg cannot be kept parallel to the right leg and the left foot cannot be supported by the structure, move the left foot until it is supported. The alignment of the sight buttons shall be maintained.
 - 4.7.2. Designated seating position: outboard rear

For rear seats or auxiliary seats, the legs are located as specified by the manufacturer. If the feet then rest on parts of the floor which are at different levels, the foot which first comes into contact with the front seat shall serve as a reference and the other foot shall be so arranged that the spirit level giving the transverse orientation of the seat of the device indicates the horizontal.
 - 4.7.3. Other designated seating positions:

The general procedure indicated in paragraph 4.7.1. above shall be followed except that the feet shall be placed as specified by the vehicle manufacturer.
- 4.8. Apply lower leg and thigh weights and level the 3-D H machine.
- 4.9. Tilt the back pan forward against the forward stop and draw the 3-D H machine away from the seat-back using the T-bar. Reposition the 3-D H machine on the seat by one of the following methods:
 - 4.9.1. If the 3-D H machine tends to slide rearward, use the following procedure. Allow the 3-D H machine to slide rearward until a forward horizontal restraining load on the T-bar is no longer required i.e. until the seat pan contacts the seat-back. If necessary, reposition the lower leg.
 - 4.9.2. If the 3-D H machine does not tend to slide rearward, use the following procedure. Slide the 3-D H machine rearwards by applying a horizontal rearward load to the T-bar until the seat pan contacts the seat-back (see figure 2 of appendix 1 to this annex).

- 4.10. Apply a 100 ± 10 N load to the back and pan assembly of the 3-D H machine at the intersection of the hip angle quadrant and the T-bar housing. The direction of load application shall be maintained along a line passing by the above intersection to a point just above the thigh bar housing (see figure 2 of appendix 1 to this annex). Then carefully return the back pan to the seat-back. Care must be exercised throughout the remainder of the procedure to prevent the 3-D H machine from sliding forward.
- 4.11. Install the right and left buttock weights and then, alternately, the eight torso weights. Maintain the 3-D H machine level.
- 4.12. Tilt the back pan forward to release the tension on the seat-back. Rock the 3-D H machine from side to side through a 10° arc (5° to each side of the vertical centre plane) for three complete cycles to release any accumulated friction between the 3-D H machine and the seat.

During the rocking action, the T-bar of the 3-D H machine may tend to diverge from the specified horizontal and vertical alignment. The T-bar must therefore be restrained by applying an appropriate lateral load during the rocking motions. Care shall be exercised in holding the T-bar and rocking the 3-D H machine to ensure that no inadvertent exterior loads are applied in a vertical or fore and aft direction.

The feet of the 3-D H machine are not to be restrained or held during this step. If the feet change position, they should be allowed to remain in that attitude for the moment.

Carefully return the back pan to the seat-back and check the two spirits levels for zero position. If any movement of the feet has occurred during the rocking operation of the 3-D H machine, they must be repositioned as follows:

Alternately, lift each foot off the floor the minimum necessary amount until no additional foot movement is obtained. During this lifting, the feet are to be free to rotate; and no forward or lateral loads are to be applied. When each foot is placed back in the down position, the heel is to be in contact with the structure designed for this.

Check the lateral spirit level for zero position; if necessary, apply a lateral load to the top of the back pan sufficient to level the 3-D H machine's seat pan on the seat.

- 4.13. Holding the T-bar to prevent the 3-D H machine from sliding forward on the seat cushion, proceed as follows:
- (a) return the back pan to the seat-back;
 - (b) alternately apply and release a horizontal rearward load, not to exceed 25 N, to the back angle bar at a height approximately at the centre of the torso weights until the hip angle quadrant indicates that a stable position has been reached after load release. Care shall be exercised to ensure that no exterior downward or lateral loads are applied to the 3-D H machine. If another level adjustment of the 3-D H machine is necessary, rotate the back pan forward, re-level, and repeat the procedure from paragraph 4.12.
- 4.14. Take all measurements:
-

- 4.14.1. The co-ordinates of the "H" point are measured with respect to the three-dimensional reference system.
- 4.14.2. The actual torso angle is read at the back angle quadrant of the 3-D H machine with the probe in its fully rearward position.
- 4.15. If a re-run of the installation of the 3-D H machine is desired, the seat assembly should remain unloaded for a minimum period of 30 min prior to the re-run. The 3-D H machine should not be left loaded on the seat assembly longer than the time required to perform the test.
- 4.16. If the seats in the same row can be regarded as similar (bench seat, identical seats, etc.) only one "H" point and one "actual torso angle" shall be determined for each row of seats, the 3-D H machine described in appendix 1 to this annex being seated in a place regarded as representative for the row. This place shall be:
 - 4.16.1. in the case of the front row, the driver's seat;
 - 4.16.2. in the case of the rear row or rows, an outer seat.

Annex 6 - Appendix 1
DESCRIPTION OF THE THREE-DIMENSIONAL "H" POINT MACHINE ^{*/-10}

(3-D H machine)

1. Back and seat pans

The back and seat pans are constructed of reinforced plastic and metal; they simulate the human torso and thigh and are mechanically hinged at the "H" point. A quadrant is fastened to the probe hinged at the "H" point to measure the actual torso angle. An adjustable thigh bar, attached to the seat pan, establishes the thigh centreline and serves as a baseline for the hip angle quadrant.

2. Body and leg elements

Lower leg segments are connected to the seat pan assembly at the T-bar joining the knees, which is a lateral extension of the adjustable thigh bar. Quadrants are incorporated in the lower leg segments to measure knee angles. Shoe and foot assemblies are calibrated to measure the foot angle. Two spirit levels orient the device in space. Body element weights are placed at the corresponding centres of gravity to provide seat penetration equivalent to a 76 kg male. All joints of the 3-D H machine should be checked for free movement without encountering noticeable friction.

^{*/-10} For details of the construction of the 3-D H machine refer to Society of Automobile Engineers (SAE), 400 Commonwealth Drive, Warrendale, Pennsylvania 15096, United States of America. The machine corresponds to that described in ISO Standard 6549-1980.

Figure 1 - 3-D H machine elements designation

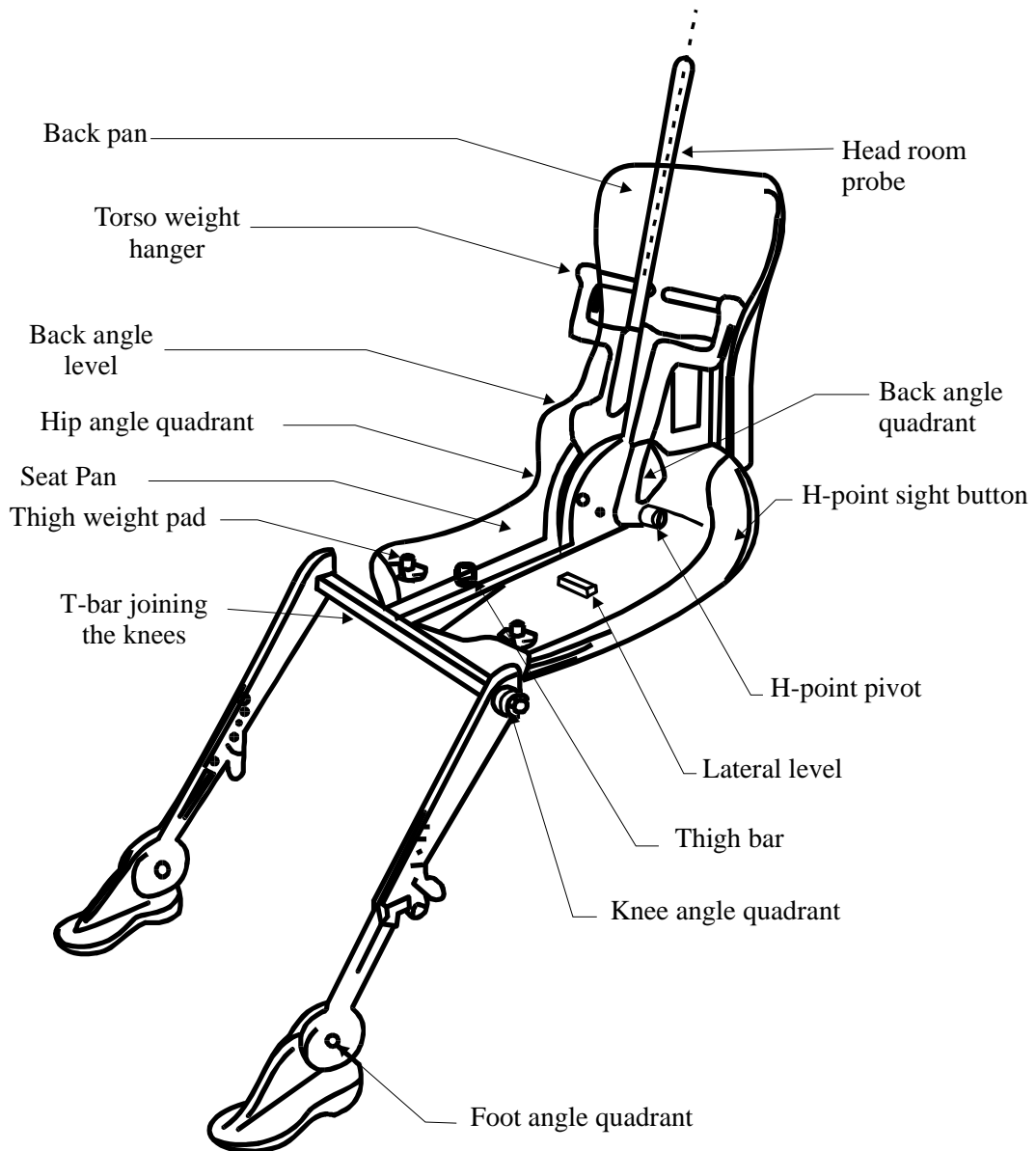
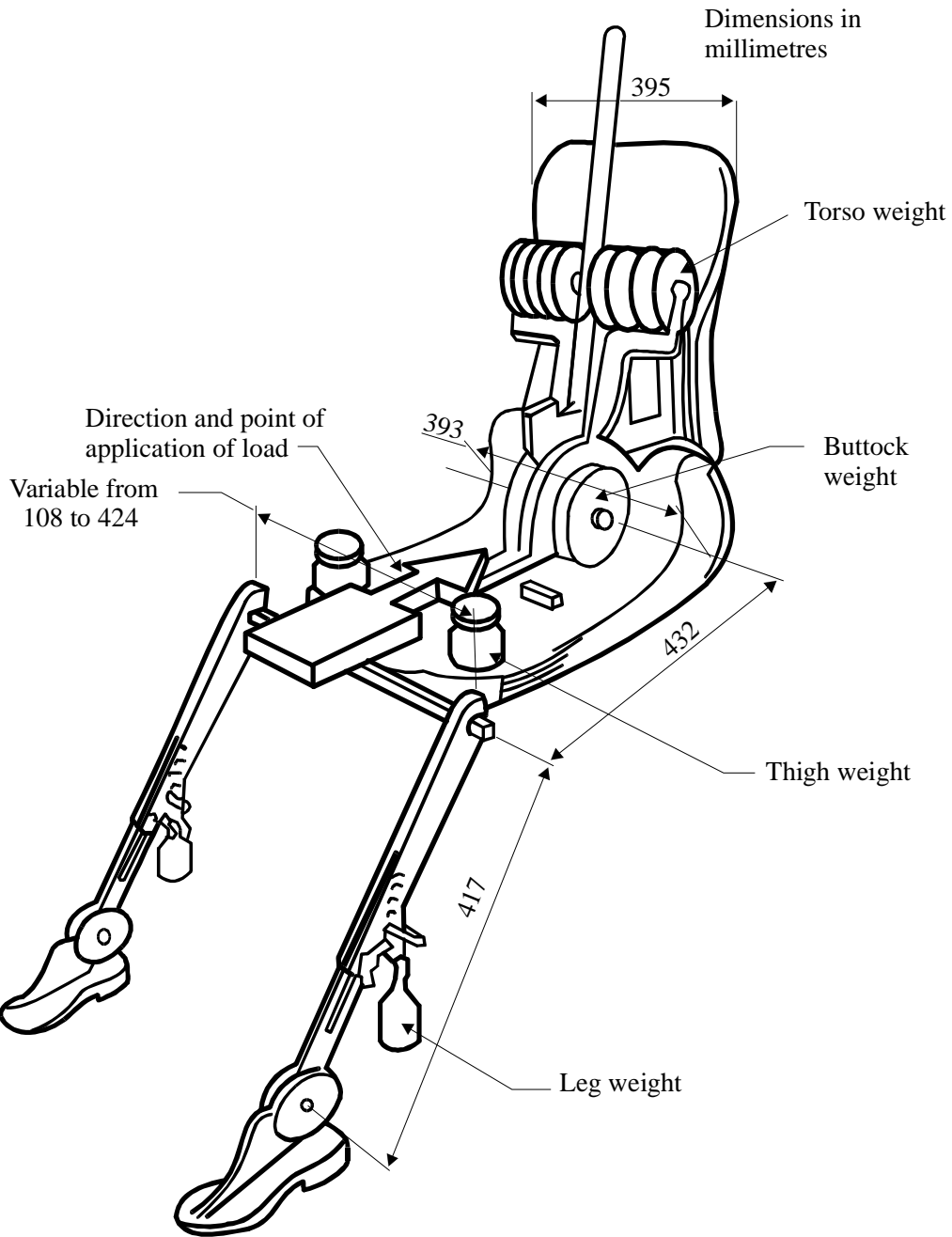
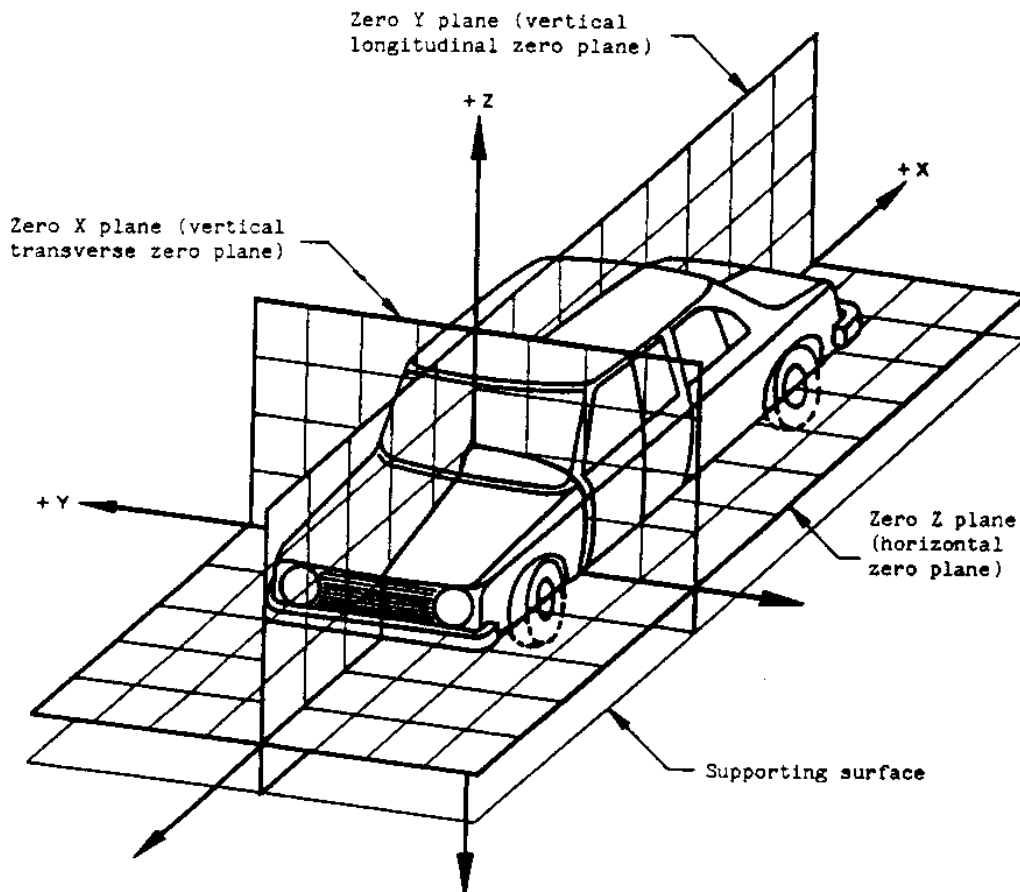

Figure 2 –
Dimensions of the 3-D H machine elements and load distribution



Annex 6 - Appendix 2 THREE-DIMENSIONAL REFERENCE SYSTEM

1. The three-dimensional reference system is defined by three orthogonal planes established by the vehicle manufacturer (see figure).^{*/-11}
2. The vehicle measuring attitude is established by positioning the vehicle on the supporting surface such that the co-ordinates of the fiducial marks correspond to the values indicated by the manufacturer.



3. The co-ordinates of the "R" point and the "H" point are established in relation to the fiducial marks defined by the vehicle manufacturer.

^{*/-11} The reference system corresponds to ISO Standard 4130, 1978.

Annex 6 - Appendix 3
REFERENCE DATA CONCERNING SEATING POSITIONS

1. Coding of reference data
Reference data are listed consecutively for each seating position. Seating positions are identified by a two-digit code. The first digit is an Arabic numeral and designates the row of seats, counting from the front to the rear of the vehicle. The second digit is a capital letter which designates the location of the seating position in a row, as viewed in the direction of forward motion of the vehicle; the following letters shall be used:
L = left
C = centre
R = right
 2. Description of vehicle measuring attitude
 - 2.1. Co-ordinates of fiducial marks
X
Y
Z
 3. List of reference data
 - 3.1. Seating position:
 - 3.1.1. Co-ordinates of "R" point
X
Y
Z
 - 3.1.2. Design torso angle:
 - 3.1.3. Specifications for seat adjustment ^{*/-12}
horizontal :
vertical :
angular :
torso angle:
- Note: List reference data for further seating positions under 3.2., 3.3., etc.

^{*/-12} Strike out what does not apply.

Annex 7

TEST PROCEDURE WITH TROLLEY

1. TEST INSTALLATION AND PROCEDURE

1.1. Trolley

The trolley shall be so constructed that no permanent deformation appears after the test. It shall be so guided that, during the impact phase, the deviation in the vertical plane does not exceed 5° and 2° in the horizontal plane.

1.2. State of the structure

1.2.1. General

The structure tested shall be representative of the series production of the vehicles concerned. Some components may be replaced or removed where such replacement or removal clearly has no effect on the test results.

1.2.2. Adjustments

Adjustments shall conform to those set out in paragraph 1.4.3. of annex 3 to this Regulation, taking into account what is stated in paragraph 1.2.1.

1.3. Attachment of the structure

1.3.1. The structure shall be firmly attached to the trolley in such a way that no relative displacement occurs during the test.

1.3.2. The method used to fasten the structure to the trolley shall not have the effect of strengthening the seat anchorages or restraint devices, or of producing any abnormal deformation of the structure.

1.3.3. The attachment device recommended is that whereby the structure rests on supports placed approximately in the axis of the wheels or, if possible, whereby the structure is secured to the trolley by the fastenings of the suspension system.

1.3.4. The angle between the longitudinal axis of the vehicle and the direction of motion of the trolley shall be $0^\circ \pm 2^\circ$.

1.4. Dummies

The dummies and their positioning shall conform to the specifications in annex 3, paragraph 2.

1.5. Measuring apparatus

1.5.1. Deceleration of the structure

The position of the transducers measuring the deceleration of the structure during the impact shall be parallel to the longitudinal axis of the trolley according to the specifications of annex 8 (CFC 180).

1.5.2. Measurements to be made on the dummies

All the measurements necessary for checking the listed criteria are set out in annex 3, paragraph 5.

1.6. Deceleration curve of the structure

The deceleration curve of the structure during the impact phase shall be such that the "variation of speed in relation to time" curve obtained by integration at no point differs by more than ± 1 m/s from the "variation of speed in relation to time" reference curve of the vehicle concerned as defined in appendix to this annex. A displacement with regard to the time axis of the reference curve may be used to obtain the structure velocity inside the corridor.

1.7. Reference curve $\Delta V = f(t)$ of the vehicle concerned

This reference curve is obtained by integration of the deceleration curve of the vehicle concerned measured in the frontal collision test against a barrier as provided for in paragraph 6 of annex 3 to this Regulation.

1.8. Equivalent method

The test may be performed by some other method than that of deceleration of a trolley, provided that such method complies with the requirement concerning the range of variation of speed described in paragraph 1.6.

Annex 7 – Appendix 1

EQUIVALENCE CURVE - TOLERANCE BAND FOR CURVE $\Delta V = f(t)$

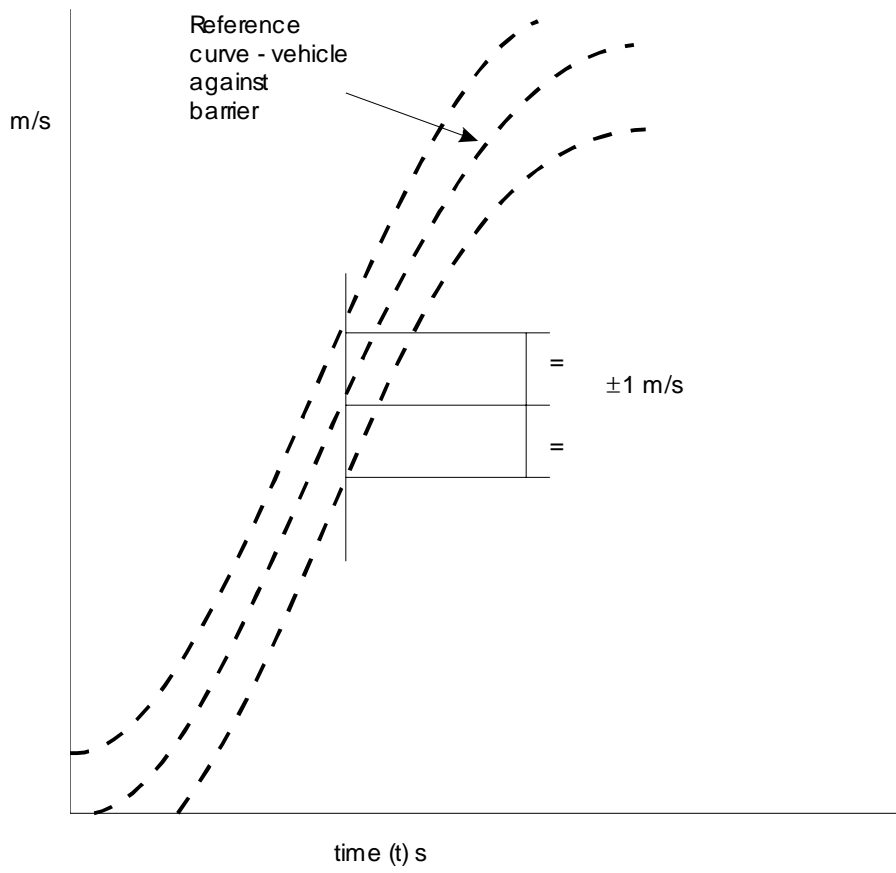

Annex 8
TECHNIQUE OF MEASUREMENT IN MEASUREMENT TESTS:
INSTRUMENTATION

1. DEFINITIONS

1.1. Data channel

A data channel comprises all the instrumentation from a transducer (or multiple transducers whose outputs are combined in some specified way) up to and including any analysis procedures that may alter the frequency content or the amplitude content of data.

1.2. Transducer

The first device in a data channel used to convert a physical quantity to be measured into a second quantity (such as an electrical voltage) which can be processed by the remainder of the channel.

1.3. Channel amplitude class: CAC

The designation for a data channel that meets certain amplitude characteristics as specified in this annex. The CAC number is numerically equal to the upper limit of the measurement range.

1.4. Characteristic frequencies F_H , F_L , F_N

These frequencies are defined in figure 1.

1.5. Channels frequency class: CFC

The channel frequency class is designated by a number indicating that the channel frequency response lies within the limits specified in figure 1. This number and the value of the frequency F_H in Hz are numerically equal.

1.6. Sensitivity coefficient

The slope of the straight line representing the best fit to the calibration values determined by the method of least square within the channel amplitude class.

1.7. Calibration factor of a data channel

The mean value of the sensitivity coefficients evaluated over frequencies which are evenly spaced on a logarithmic scale between F_L and $F_H/2.5$

1.8. Linearity error

The ratio, in per cent, of the maximum difference between the calibration value and the corresponding value read on the straight line defined in paragraph 1.6. at the upper limit of the channel amplitude class.

1.9. Cross sensitivity

The ratio of the output signal to the input signal, when an excitation is applied to the transducer perpendicular to the measurement axis. It is expressed as a percentage of the sensitivity along the measurement axis.

1.10. Phase delay time

The phase delay time of a data channel is equal to the phase delay (in radians) of a sinusoidal signal, divided by the angular frequency of that signal (in radians/second).

1.11. Environment

The aggregate, at a given moment, of all external conditions and influences to which the data channel is subjected.

2. PERFORMANCE REQUIREMENTS

2.1. Linearity error

The absolute value of the linearity error of a data channel at any frequency in the CFC, shall be equal to or less than 2.5 per cent of the value of the CAC, over the whole measurement range.

2.2. Amplitude against frequency

The frequency response of a data channel shall lie within the limiting curves given in figure 1. The zero dB line is determined by the calibration factor.

2.3. Phase delay time

The phase delay time between the input and the output signals of a data channel shall be determined and shall not vary by more than $1/10 F_H$ seconds between $0.03 F_H$ and F_H .

2.4. Time

2.4.1. Time base

A time base shall be recorded and shall at least give $1/100$ s with an accuracy of 1 per cent.

2.4.2. Relative time delay

The relative time delay between the signal of two or more data channels, regardless of their frequency class, must not exceed 1 ms excluding delay caused by phase shift.

Two or more data channels of which the signals are combined shall have the same frequency class and shall not have relative time delay greater than $1/10 F_H$ seconds.

This requirement applies to analogue signals as well as to synchronisation pulses and digital signals.

2.5. Transducer cross sensitivity

The transducer cross sensitivity shall be less than 5 per cent in any direction.

2.6. Calibration

2.6.1. General

A data channel shall be calibrated at least once a year against reference equipment traceable to known standards. The methods used to carry out a comparison with reference equipment shall not introduce an error greater than 1 per cent of the CAC. The use of the reference equipment is limited to the frequency range for which they have been calibrated. Subsystems of a

data channel may be evaluated individually and the results factored into the accuracy of the total data channel. This can be done for example by an electrical signal of known amplitude simulating the output signal of the transducer which allows a check to be made on the gain factor of the data channel, excluding the transducer.

2.6.2. Accuracy of reference equipment for calibration

The accuracy of the reference equipment shall be certified or endorsed by an official metrology service.

2.6.2.1. Static calibration

2.6.2.1.1. Accelerations

The errors shall be less than ± 1.5 per cent of the channel amplitude class.

2.6.2.1.2. Forces

The error shall be less than ± 1 per cent of the channel amplitude class.

2.6.2.1.3. Displacements

The error shall be less than ± 1 per cent of the channel amplitude class.

2.6.2.2. Dynamic calibration

2.6.2.2.1. Accelerations

The error in the reference accelerations expressed as a percentage of the channel amplitude class shall be less than ± 1.5 per cent below 400 Hz, less than ± 2 per cent between 400 Hz and 900 Hz, and less than ± 2.5 per cent above 900 Hz.

2.6.2.3. Time

The relative error in the reference time shall be less than 10^{-5} .

2.6.3. Sensitivity coefficient and linearity error

The sensitivity coefficient and the linearity error shall be determined by measuring the output signal of the data channel against a known input signal for various values of this signal. The calibration of the data channel shall cover the whole range of the amplitude class. For bi-directional channels, both the positive and negative values shall be used. If the calibration equipment cannot produce the required input owing to the excessively high values of the quantity to be measured, calibrations shall be carried out within the limits of the calibration standards and these limits shall be recorded in the test report.

A total data channel shall be calibrated at a frequency or at a spectrum of frequencies having a significant value between F_L and $F_H/2.5$.

2.6.4. Calibration of the frequency response

The response curves of phase and amplitude against frequency shall be determined by measuring the output signals of the data channel in terms of phase and amplitude against a known input signal, for various values of this signal varying between F_L and 10 times the CFC or 3,000 Hz, whichever is lower.

2.7. Environmental effects

A regular check shall be made to identify any environmental influence (such as electric or magnetic flux, cable velocity, etc.). This can be done for instance by recording the output of spare channels equipped with dummy transducers. If significant output signals are obtained corrective action shall be taken, for instance by replacement of cables.

2.8. Choice and designation of the data channel

The CAC and CFC define a data channel.

The CAC shall be 1, 2 or 5 to a power of ten.

3. MOUNTING OF TRANSDUCERS

Transducers should be rigidly secured so that their recordings are affected by vibration as little as possible. Any mounting having a lowest resonance frequency equal to at least 5 times the frequency F_H of the data channel considered shall be considered valid. Acceleration transducers in particular should be mounted in such a way that the initial angle of the real measurement axis to the corresponding axis of the reference axis system is not greater than 5° unless an analytical or experimental assessment of the effect of the mounting on the collected data is made. When multi-axial accelerations at a point are to be measured, each acceleration transducer axis should pass within 10 mm of that point, and the centre of seismic mass of each accelerometer should be within 30 mm of that point.

4. RECORDING

4.1. Analogue magnetic recorder

Tape speed should be stable to within not more than 0.5 per cent of the tape speed used. The signal-to-noise ratio of the recorder should not be less than 42 dB at the maximum tape speed. The total harmonic distortion should be less than 3 per cent and the linearity error should be less than 1 per cent of the measurement range.

4.2. Digital magnetic recorder

Tape speed should be stable to within not more than 10 per cent of the tape speed used.

4.3. Paper tape recorder

In case of direct data recording the paper speed in mm/s should be at least 1.5 times the number expressing F_H in Hz. In other cases the paper speed should be such that equivalent resolution is obtained.

5. DATA PROCESSING

5.1. Filtering

Filtering corresponding to the frequencies of the data channel class may be carried out during either recording or processing of data. However, before recording, analogical filtering at a higher level than CFC should be effected in order to use at least 50 per cent of the dynamic range of the recorder and

to reduce the risk of high frequencies saturating the recorder or causing aliasing errors in the digitilising process.

5.2. Digitilising

5.2.1. Sampling frequency

The sampling frequency should be equal to at least $8 F_H$. In the case of analogical recording, when the recording and reading speeds are different, the sampling frequency can be divided by the speed ratio.

5.2.2. Amplitude resolution

The size of digital words should be at least 7 bits and a parity bit.

6. PRESENTATION OF RESULTS

The results should be presented on A4 size paper (ISO/R 216). Results presented as diagrams should have axes scaled with a measurement unit corresponding to a suitable multiple of the chosen unit (for example, 1, 2, 5, 10, 20 millimetres). SI units shall be used, except for vehicle velocity, where km/h may be used, and for accelerations due to impact where g, with $g = 9.81 \text{ m/s}^2$, may be used.

Figure 1.
 Frequency response curve

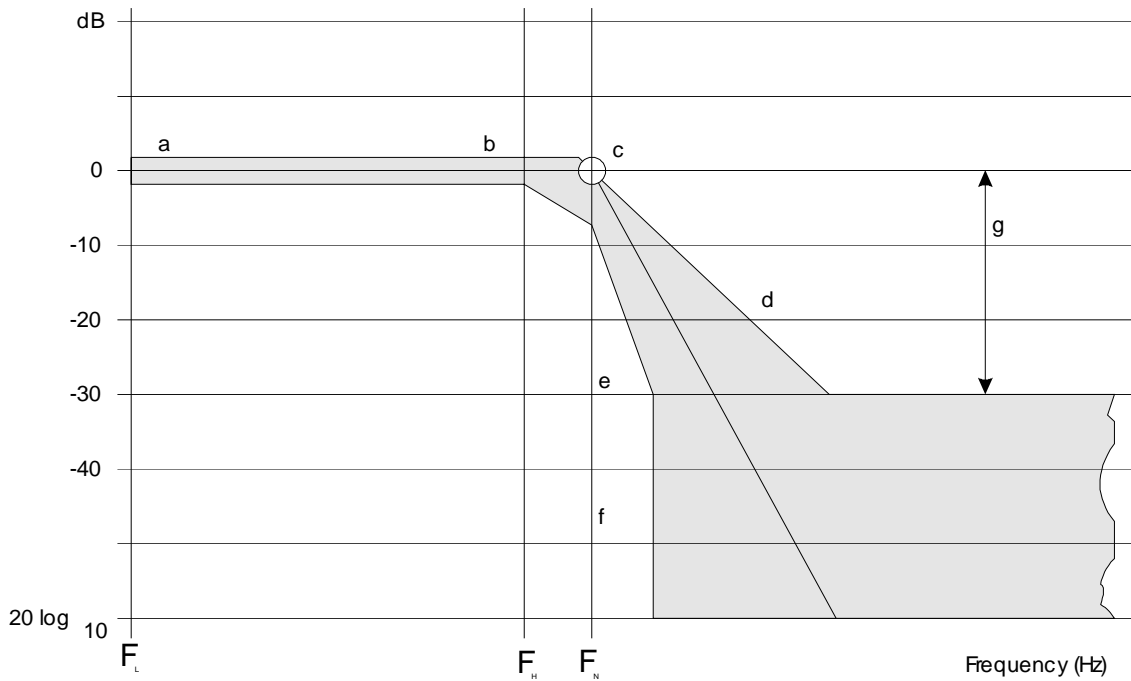

CFC	F _L Hz	F _H Hz	F _N Hz	N	Logarithmic scale	
				a	± 0.5	dB
				b	+0.5;-1	dB
				c	+0.5;-4	dB
1,000	□ 0.1	1,000	1,650	d	-9	dB/octave
600	□ 0.1	600	1,000	e	-20	dB/octave
180	□ 0.1	180	300	f	□	dB/octave
60	□ 0.1	60	100	g	-30	dB

Annex 9

DEFINITION OF DEFORMABLE BARRIER

1. COMPONENT AND MATERIAL SPECIFICATIONS

The dimensions of the barrier are illustrated in Figure 1 of this annex. The dimensions of the individual components of the barrier are listed separately below.

1.1. Main honeycomb block

Dimensions : All dimensions should allow a tolerance of $\pm 2,5$ mm

Height: 650 mm (in direction of honeycomb ribbon axis)

Width: 1000 mm

Depth: 450 mm (in direction of honeycomb cell axes)

Material: Aluminium 3003 (ISO 209, part 1)

Foil Thickness: 0.076 mm

Cell Size: 19.14 mm

Density: 28.6 kg/m³

Crush Strength: 0.342 MPa +0% -10% ^{1/}

1.2. Bumper element

Dimensions: All dimensions should allow a tolerance of $\pm 2,5$ mm

Height: 330 mm (in direction of honeycomb ribbon axis)

Width: 1000 mm

Depth: 90 mm (in direction of honeycomb cell axes)

Material: Aluminium 3003 (ISO 209, part 1)

Foil Thickness: 0.076 mm

Cell size: 6.4 mm

Density: 82.6 kg/m³

Crush Strength: 1.711 MPa +0% -10% ^{1/}

1.3. Backing sheet

Dimensions

Height: 800 mm $\pm 2,5$ mm

Width: 1000 mm $\pm 2,5$ mm

Thickness: 2.0 mm ± 0.1 mm

1.4. Cladding sheet

Dimensions

Length: 1700 mm $\pm 2,5$ mm

^{1/} In accordance with the certification procedure described in paragraph 2 of this annex.

Width: 1000 mm \pm 2,5 mm

Thickness: 0.81 \pm 0.07 mm

Material: Aluminium 5251/5052 (ISO 209, part 1)

1.5. Bumper facing sheet

Dimensions

Height: 330 mm \pm 2,5 mm

Width: 1000 mm \pm 2,5 mm

Thickness: 0.81 mm \pm 0.07 mm

Material: Aluminium 5251/5052 (ISO 209, part 1)

1.6. Adhesive:

The adhesive to be used throughout should be a two-part polyurethane (such as Ciba-Geigy XB5090/1 resin with XB5304 hardener, or equivalent).

2. ALUMINIUM HONEYCOMB CERTIFICATION

A complete testing procedure for certification of aluminium honeycomb is given in NHTSA TP-214D. The following is a summary of the procedure that should be applied to materials for the frontal impact barrier, these materials having a crush strength of 0.342 MPa and 1.711 MPa respectively.

2.1. Sample locations

To ensure uniformity of crush strength across the whole of the barrier face, eight samples shall be taken from four locations evenly spaced across the honeycomb block. For a block to pass certification, seven of these eight samples shall meet the crush strength requirements of the following sections.

The location of the samples depends on the size of the honeycomb block. First, four samples, each measuring 300 mm x 300 mm x 50 mm thick shall be cut from the block of barrier face material. Please refer to Figure 2 for an illustration of how to locate these sections within the honeycomb block. Each of these larger samples shall be cut into samples for certification testing (150 mm x 150 mm x 50 mm). Certification shall be based on the testing of two samples from each of these four locations. The other two should be made available to the applicant, upon request.

2.2. Sample size

Samples of the following size shall be used for testing:

Length: 150 mm \pm 6 mm

Width: 150 mm \pm 6 mm

Thickness: 50 mm \pm 2 mm

The walls of incomplete cells around the edge of the sample shall be trimmed as follows:

In the "W" direction, the fringes shall be no greater than 1.8 mm (see Figure 3).

In the "L" direction, half the length of one bonded cell wall (in the ribbon direction) shall be left at either end of the specimen (see Figure 3).

2.3. Area measurement

The length of the sample shall be measured in three locations, 12.7 mm from each end and in the middle, and recorded as L1, L2 and L3 (Figure 3). In the same manner, the width shall be measured and recorded as W1, W2 and W3 (Figure 3). These measurements shall be taken on the centreline of the thickness. The crush area shall then be calculated as:

$$A = \frac{(L1 + L2 + L3)}{3} \times \frac{(W1 + W2 + W3)}{3}$$

2.4. Crush rate and distance

The sample shall be crushed at a rate of not less than 5.1 mm/min and not more than 7.6 mm/min. The minimum crush distance shall be 16.5 mm.

2.5. Data collection

Force versus deflection data are to be collected in either analog or digital form for each sample tested. If analog data are collected then a means of converting this to digital shall be available. All digital data shall be collected at a rate of not less than 5 Hz (5 points per second).

2.6. Crush strength determination

Ignore all data prior to 6.4 mm of crush and after 16.5 mm of crush. Divide the remaining data into three sections or displacement intervals (n = 1, 2, 3) (see Figure 4) as follows:

- (1) 06.4 mm - 09.7 mm inclusive,
- (2) 09.7 mm - 13.2 mm exclusive,
- (3) 13.2 mm - 16.5 mm inclusive.

Find the average for each section as follows:

$$F(n) = \frac{[F(n)1 + F(n)2 + \dots + F(n)m]}{m}; m = 1, 2, 3$$

where m represents the number of data points measured in each of the three intervals. Calculate the crush strength of each section as follows:

$$S(n) = \frac{F(n)}{A}; n = 1, 2, 3$$

2.7. Sample crush strength specification

For a honeycomb sample to pass this certification, the following conditions shall be met:

0.308 MPa \leq S(n) \leq 0.342 MPa for 0.342 MPa material

1.540 MPa \leq S(n) \leq 1.711 MPa for 1.711 MPa material

n = 1, 2, 3.

2.8. Block crush strength specification

Eight samples are to be tested from four locations, evenly spaced across the block. For a block to pass certification, seven of the eight samples shall meet the crush strength specification of the previous section.

3. ADHESIVE BONDING PROCEDURE

3.1. Immediately before bonding, aluminium sheet surfaces to be bonded shall be thoroughly cleaned using a suitable solvent, such as 1-1-1 Trichloroethane.

This is to be carried out at least twice or as required to eliminate grease or dirt deposits. The cleaned surfaces shall then be abraded using 120 grit abrasive paper.

Metallic/Silicon Carbide abrasive paper is not to be used. The surfaces shall be thoroughly abraded and the abrasive paper changed regularly during the process to avoid clogging, which may lead to a polishing effect. Following abrading, the surfaces shall be thoroughly cleaned again, as above. In total, the surfaces shall be solvent cleaned at least four times. All dust and deposits left as a result of the abrading process shall be removed, as these will adversely affect bonding.

3.2. The adhesive should be applied to one surface only, using a ribbed rubber roller. In cases where honeycomb is to be bonded to aluminium sheet, the adhesive should be applied to the aluminium sheet only. A maximum of 0.5 kg/m² shall be applied evenly over the surface, giving a maximum film thickness of 0.5 mm.

4. CONSTRUCTION

4.1. The main honeycomb block shall be bonded to the backing sheet with adhesive such that the cell axes are perpendicular to the sheet.

The cladding shall be bonded to the front surface of the honeycomb block. The top and bottom surfaces of the cladding sheet shall not be bonded to the main honeycomb block but should be positioned closely to it. The cladding sheet shall be adhesively bonded to the backing sheet at the mounting flanges.

4.2. The bumper element shall be adhesively bonded to the front of the cladding sheet such that the cell axes are perpendicular to the sheet.

The bottom of the bumper element shall be flush with the bottom surface of the cladding sheet. The bumper facing sheet shall be adhesively bonded to the front of the bumper element.

4.3. The bumper element shall then be divided into three equal sections by means of two horizontal slots.

These slots shall be cut through the entire depth of the bumper section and extend the whole width of the bumper. The slots shall be cut using a saw; their width shall be the width of the blade used and shall not exceed 4.0 mm.

4.4. Clearance holes for mounting the barrier are to be drilled in the mounting flanges (shown in Figure 5).

The holes shall be of 9.5 mm diameter. Five holes shall be drilled in the top flange at a distance of 40 mm from the top edge of the flange and five in the bottom flange, 40 mm from the bottom edge of that flange. The holes shall be at 100 mm, 300 mm, 500 mm, 700 mm, 900 mm from either edge of the barrier distances. All holes shall be drilled to ± 1 mm of the nominal

5. MOUNTING

- 5.1. The deformable barrier shall be rigidly fixed to the edge of a mass of not less than 7×10^4 kg or to some structure attached thereto.

The attachment of the barrier face shall be such that the vehicles shall not contact any part of the structure more than 75 mm from the top surface of the barrier (excluding the upper flange) during any stage of the impact^{2/}. The front face of the surface to which the deformable barrier is attached shall be flat and continuous over the height and width of the face and shall be vertical $\pm 1^\circ$ and perpendicular $\pm 1^\circ$ to the axis of the run-up track. The attachment surface shall not be displaced by more than 10 mm during the test. If necessary, additional anchorage or arresting devices shall be used to prevent displacement of the concrete block. The edge of the deformable barrier shall be aligned with the edge of the concrete block appropriate for the side of the vehicle to be tested.

- 5.2. The deformable barrier shall be fixed to the concrete block by means of ten bolts, five in the top mounting flange and five in the bottom.

These bolts shall be of at least 8 mm diameter. Steel clamping strips shall be used for both the top and bottom mounting flanges (see Figures 1 and 5). These strips shall be 60 mm high and 1000 mm wide and have a thickness of at least 3 mm. Five clearance holes of 9.5 mm diameter shall be drilled in both strips to correspond with those in the mounting flange on the barrier (see paragraph 4). None of the fixtures shall fail in the impact test.

^{2/} A mass, the end of which is between 925 mm and 1,000 mm high and at least 1,000 mm deep, is considered to satisfy this requirement.

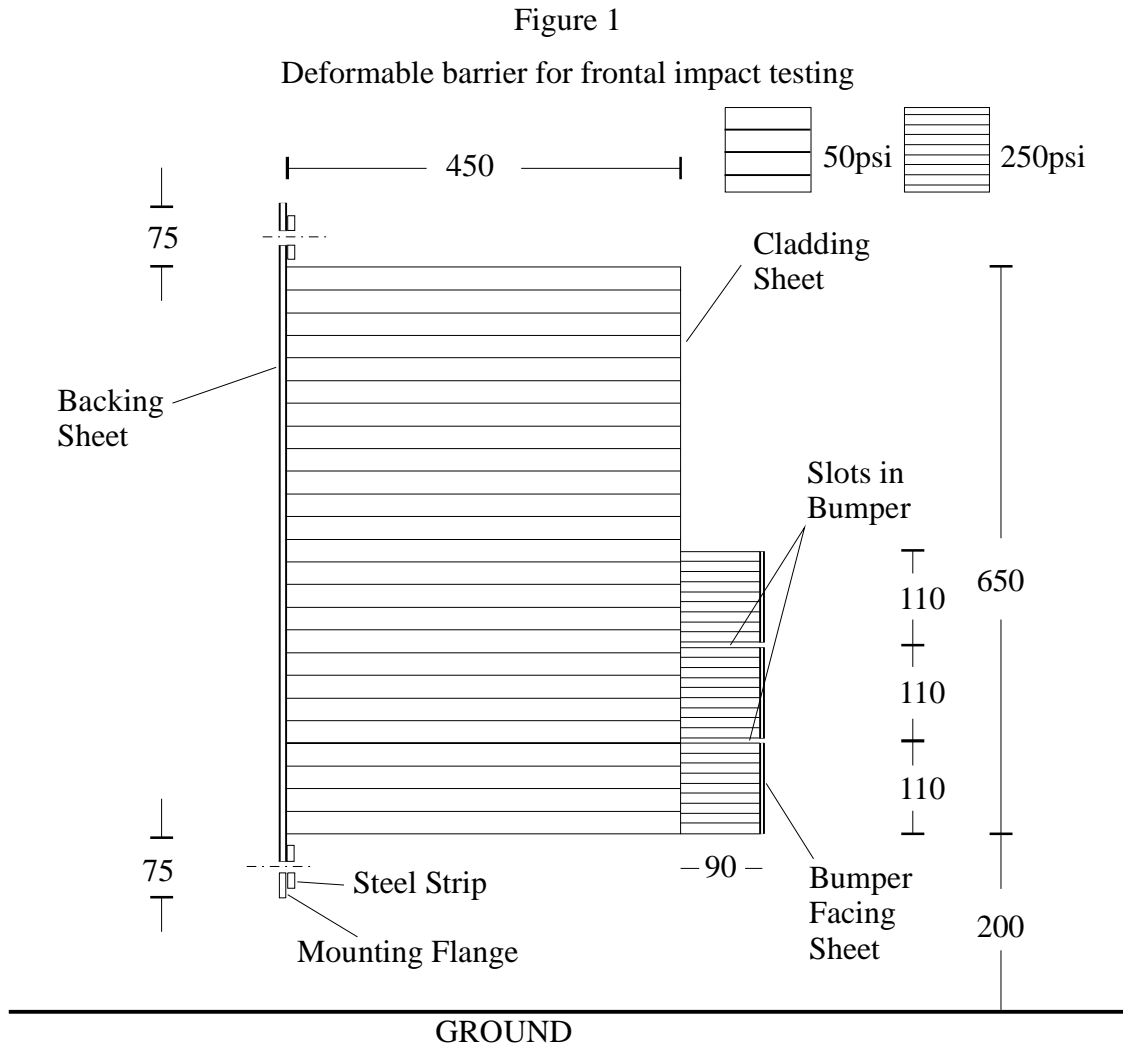

Barrier width = 1000 mm.

All dimensions in mm.

Figure 2
Locations of samples for certification

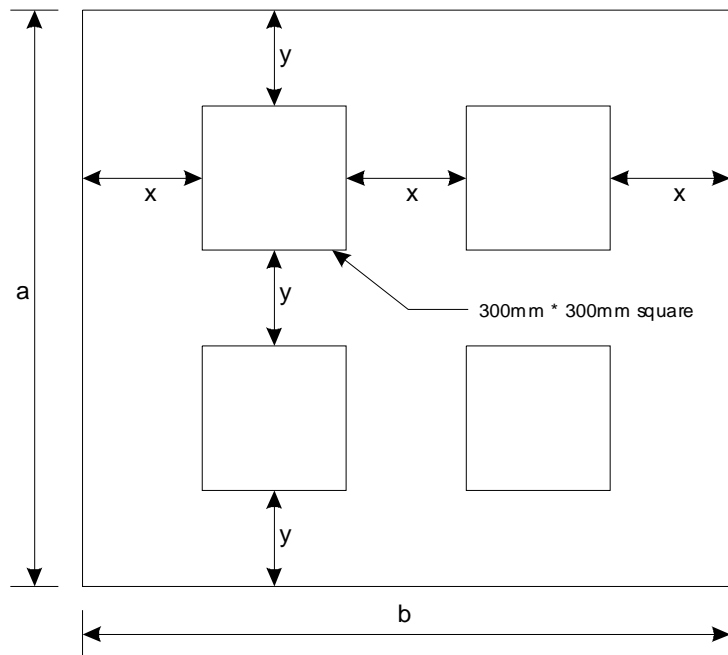

If $a \geq 900\text{mm}$: $x = 1/3(b-600\text{mm})$ and $y = 1/3(a-600\text{mm})$ (for $a \leq b$)

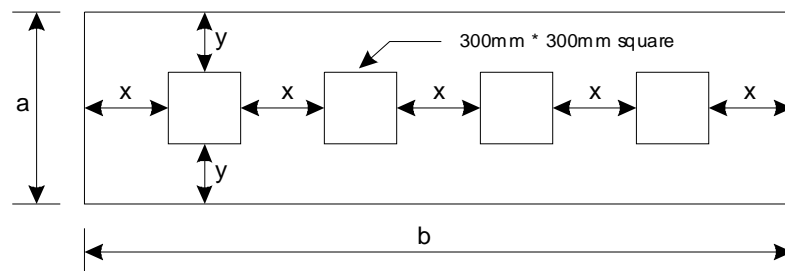

If $a < 900\text{mm}$: $x = 1/5(b-1200\text{mm})$ and $y = 1/2(a-300\text{mm})$ for $a \leq b$

Figure 3
Honeycomb axes and measured dimensions

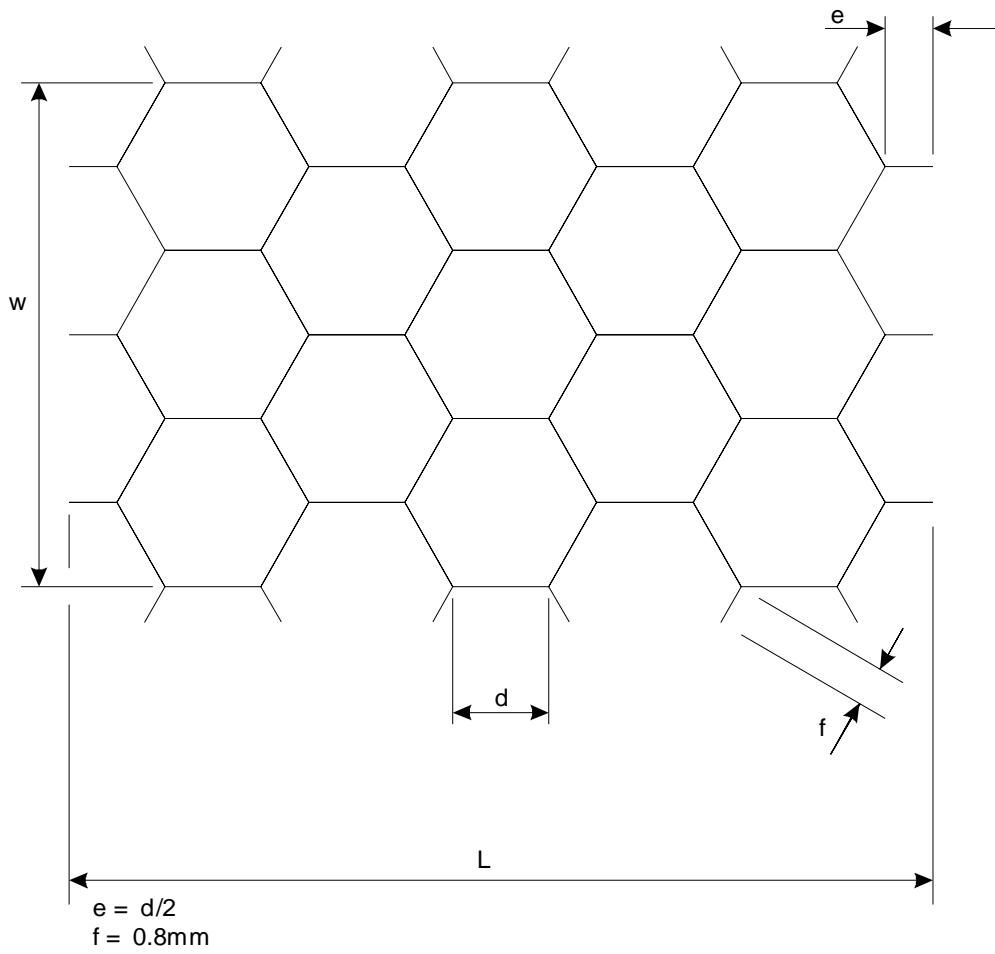

Figure 4
Crush force and displacement

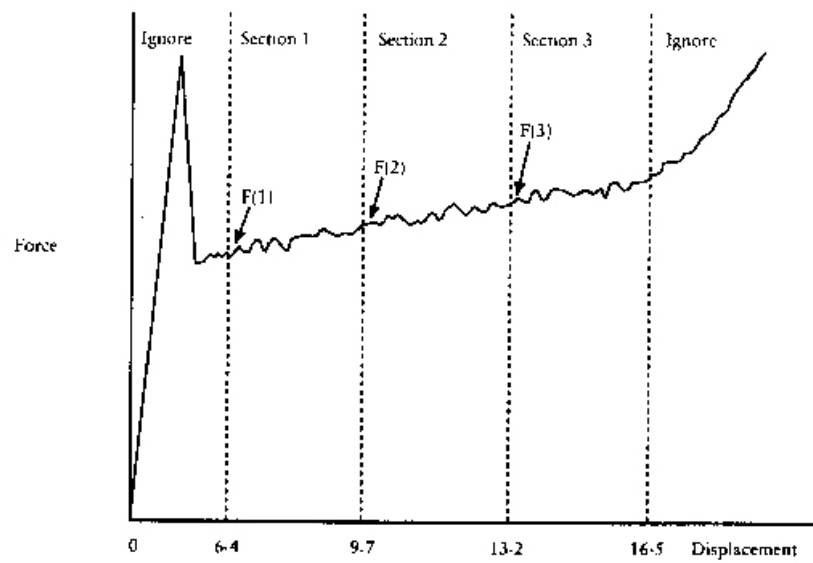
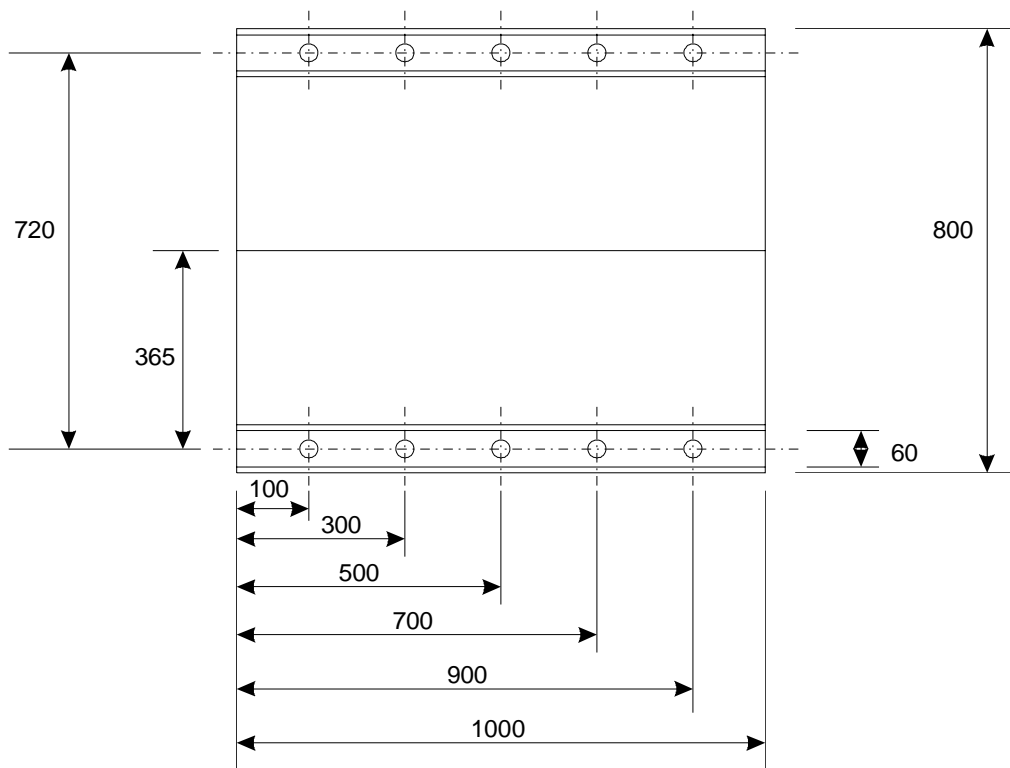

Figure 5
Positions of holes for barrier mounting



Hole diameters 9,5 mm.
All dimensions in mm.

Annex 10
CERTIFICATION PROCEDURE FOR THE DUMMY LOWER LEG AND FOOT

1. TIBIA IMPACT TEST

- 1.1. The objective of this test is to measure the response of Hybrid III tibia skin and insert to well-defined, hard-faced pendulum impacts.
- 1.2. Left and right Hybrid III leg assemblies, from the knee clevis joint down, shall be used. Each shall be attached rigidly to the test fixture.
- 1.3. Test procedure
 - 1.3.1. Each leg assembly shall be maintained (soaked) for 4 hours prior to the test at a temperature of $22 \pm 3^{\circ}\text{C}$ and a relative humidity of $40 \square 30$ per cent. The soak period shall not include the time required to reach steady state conditions.
 - 1.3.2. Align the impactor accelerometer with its sensitive axis parallel to the impactor longitudinal centre line.
 - 1.3.3. Clean the impact surface of the skin and also the impactor face with isopropyl alcohol or equivalent prior to the test.
 - 1.3.4. Mount the leg assembly to the fixture at the knee clevis joint, as shown in Figure 1. The test fixture shall be rigidly secured to prevent movement during impact. The test fixture shall be constructed such that there is no contact with any part of the leg assembly, other than at the fixing point, during the test. The line between the knee clevis joint and the centre of the ankle joint shall be vertical $\pm 5^{\circ}$. Adjust the knee and ankle joint to $1,5 \pm 0,5$ g range before each test.
 - 1.3.5. The rigid impactor shall have a mass of $5,0 \pm 0,2$ kg including instrumentation. The impact face shall be a half cylinder with its principal axis horizontal $\pm 1^{\circ}$ and perpendicular to the direction of impact. The radius of the impact surface shall be 40 ± 2 mm and the width of the impact surface shall be at least 80 mm. The impactor shall strike the tibia at a point midway between the knee clevis joint and the ankle pivot along the centre line of the tibia. The impactor shall strike the tibia so that the horizontal centre line of the impactor falls within $0,5^{\circ}$ of a horizontal line parallel to the femur load cell simulator at time-zero. The impactor shall be guided to exclude significant lateral, vertical or rotational movement at time-zero .
 - 1.3.6. Allow a period of at least 30 minutes between successive tests on the same leg.
 - 1.3.7. The data acquisition system, including transducers, shall conform to the specifications for CFC 600, as described in annex 8.
- 1.4. Performance specification
 - 1.4.1. When each tibia is impacted at $2.1 \pm 0,3$ m/s in accordance with paragraph 1.3., the impact force, which is the product of the pendulum mass and the deceleration, shall be $2.3 \pm 0,3$ kN.

2. UPPER FOOT IMPACT TEST

- 2.1. The objective of this test is to measure the response of the Hybrid III foot and ankle to well-defined, hard-faced pendulum impacts.
- 2.2. The complete Hybrid III lower leg assembly, left (86-5001-001) and right (86-5001-002), equipped with the foot and ankle assembly, left (78051-614) and right (78051-615), shall be used, including the knee assembly. The load cell simulator (78051-319 Rev A) shall be used to secure the knee-cap assembly (78051-16 Rev B) to the test fixture.
- 2.3. Test procedure
 - 2.3.1. Each leg assembly shall be maintained (soaked) for 4 hours prior to the test at a temperature of $22 \pm 3^{\circ}\text{C}$ and a relative humidity of 40 ± 30 per cent. The soak period shall not include the time required to reach steady state conditions.
 - 2.3.2.
 - a) Clean the impact surface of the skin and also the impactor face with isopropyl alcohol or equivalent prior to the test.
 - b) Align the impactor accelerometer with its sensitive axis parallel to the direction of impact at contact with the foot.
 - 2.3.3. Mount the leg assembly to the fixture shown in Figure 1a. The test fixture shall be secured rigidly to prevent movement during the impact test. The centre line of the femur load cell simulator (78051-319) shall be vertical $\pm 0,5^{\circ}$. Adjust the mount such that the line joining the knee clevis joint and the ankle attachment bolt is horizontal $\pm 3^{\circ}$ with the heel resting on two sheets of low-friction (PTFE) material. Ensure that the tibia flesh is located towards the knee end of the tibia. Adjust the ankle such that the plane of the underside of the foot is vertical $\pm 3^{\circ}$. Adjust the knee and ankle joint to $1,5 \pm 0,5$ g range before each test.
 - 2.3.4. The rigid impactor comprises a horizontal cylinder diameter 50 ± 2 mm and a pendulum support arm diameter 19 ± 1 mm (Figure 3a). The cylinder has a mass of $1,25 \pm 0,02$ kg including instrumentation and any part of the support arm within the cylinder. The pendulum arm has a mass of 285 ± 5 g. The mass of any rotating part of the axle to which the support arm is attached should not be greater than 100 g. The length between the central horizontal axis of the impactor cylinder and the axis of rotation of the whole pendulum shall be 1250 ± 1 mm. The impact cylinder is mounted with its longitudinal axis horizontal and perpendicular to the direction of impact. The pendulum shall impact the underside of the foot, at a distance of 185 ± 2 mm from the base of the heel resting on the rigid horizontal platform, so that the longitudinal centre line of the pendulum arm falls within 1° of a vertical line at impact. The impactor shall be guided to exclude significant lateral, vertical or rotational movement at time-zero.
 - 2.3.5. Allow a period of at least 30 minutes between successive tests on the same leg.
 - 2.3.6. The data acquisition system, including transducers, shall conform to the specifications for CFC 600, as described in annex 8.

- 2.4. Performance specifications
 - 2.4.1. When the ball of each foot is impacted at $6,7 \pm 0,2$ m/s in accordance with paragraph 2.3., the maximum tibia bending moment about they-axis (M_y) shall be between 100 Nm and 140 Nm.
3. LOWER FOOT IMPACT TEST
 - 3.1. The objective of this test is to measure the response of the Hybrid III foot skin and insert to well-defined, hard-faced pendulum impacts.
 - 3.2. The complete Hybrid III lower leg assembly, left (86-5001-001) and right (86-5001-002), equipped with the foot and ankle assembly, left (78051-614) and right (78051-615), shall be used, including the knee assembly. The load cell simulator (78051-319 Rev A) shall be used to secure the knee-cap assembly (78051-16 Rev B) to the test fixture.
 - 3.3. Test procedure
 - 3.3.1. Each leg assembly shall be maintained (soaked) for 4 hours prior to the test at a temperature of $22 \pm 3^\circ\text{C}$ and a relative humidity of 40 ± 30 per cent. The soak period shall not include the time required to reach steady state conditions.
 - 3.3.2. Align the impactor accelerometer with its sensitive axis parallel to the impactor longitudinal centre line.
 - 3.3.3. Clean the impact surface of the skin and also the impactor face with isopropyl alcohol or equivalent prior to the test.
 - 3.3.4. Mount the leg assembly to the fixture shown in Figure 1b. The test fixture shall be secured rigidly to prevent movement during the impact test. The centre line of the femur load cell simulator (78051-319) shall be vertical $\pm 0,5^\circ$. Adjust the mount such that the line joining the knee clevis joint and the ankle attachment bolt is horizontal $\pm 3^\circ$ with the heel resting on two sheets of low-friction (PTFE) material. Ensure that the tibia flesh is located towards the knee end of the tibia. Adjust the ankle such that the plane of the underside of the foot is vertical $\pm 3^\circ$. Adjust the knee and ankle joint to $1,5 \pm 0,5$ g range before each test.
 - 3.3.5. The rigid impactor comprises a horizontal cylinder diameter 50 ± 2 mm and a pendulum support arm diameter 19 ± 1 mm (Figure 3a). The cylinder has a mass of $1,25 \pm 0,02$ kg including instrumentation and any part of the support arm within the cylinder. The pendulum arm has a mass of 285 ± 5 g. The mass of any rotating part of the axle to which the support arm is attached should not be greater than 100 g. The length between the central horizontal axis of the impactor cylinder and the axis of rotation of the whole pendulum shall be 1250 ± 1 mm. The impact cylinder is mounted with its longitudinal axis horizontal and perpendicular to the direction of impact. The pendulum shall impact the underside of the foot, at a distance of 62 ± 2 mm from the base of the heel resting on the rigid horizontal platform, so that the longitudinal centre line of the pendulum arm falls within 1° of a vertical line at impact. The impactor shall be guided to exclude significant lateral, vertical or rotational movement at time-zero.

- 3.3.6. Allow a period of at least 30 minutes between successive tests on the same leg.
- 3.3.7. The data acquisition system, including transducers, shall conform to the specifications for CFC 600, as described in annex 8.
- 3.4. Performance specification
 - 3.4.1. When the heel of each foot is impacted at $4,4 \pm 0,2$ m/s in accordance with paragraph 3.3., the maximum impactor acceleration shall be 340 ± 50 g.

Figure 1

Tibia impact test - test set-up specifications

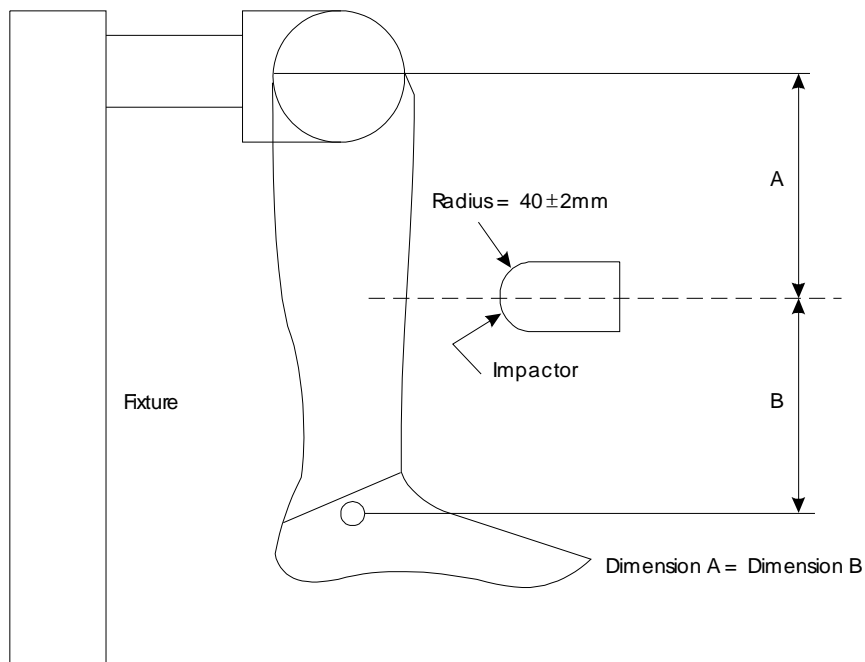

Figure 1a
Upper foot impact test - test set-up specifications

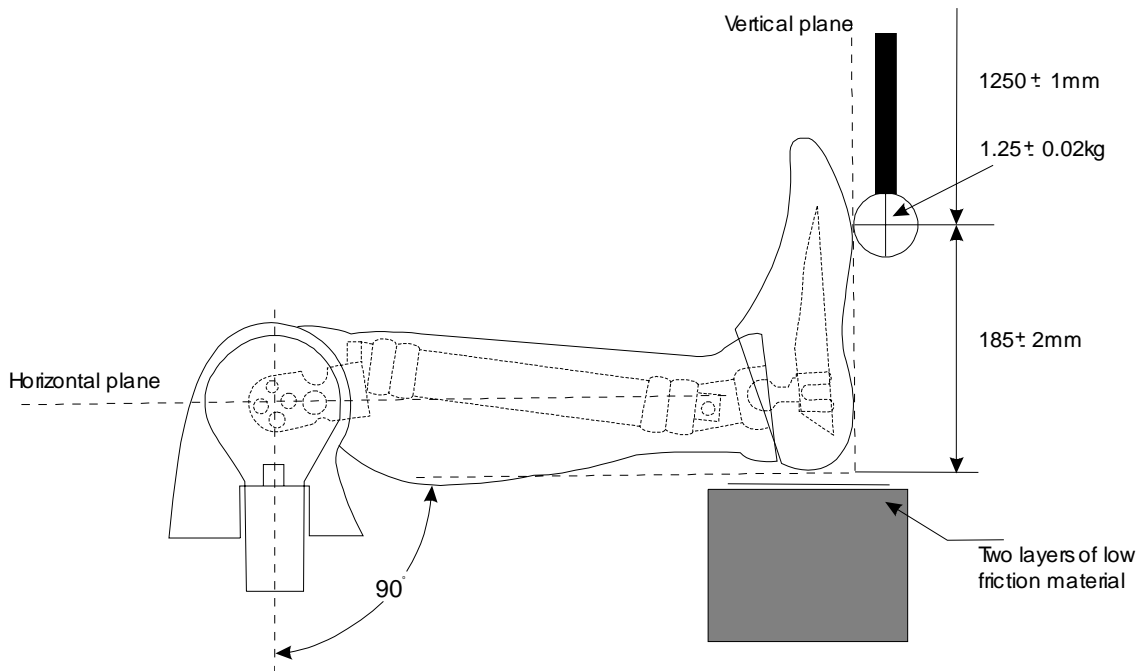

Figure 1b
Lower foot impact test - test set-up specifications

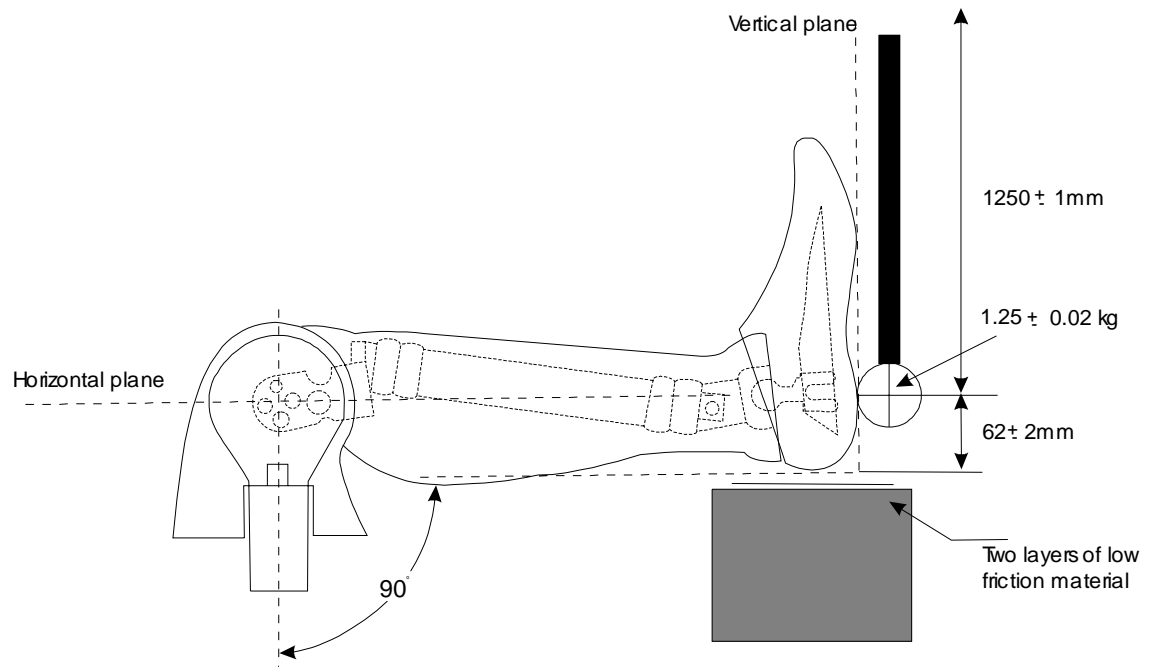

Figure 2
Upper foot impact test - test set-up specifications

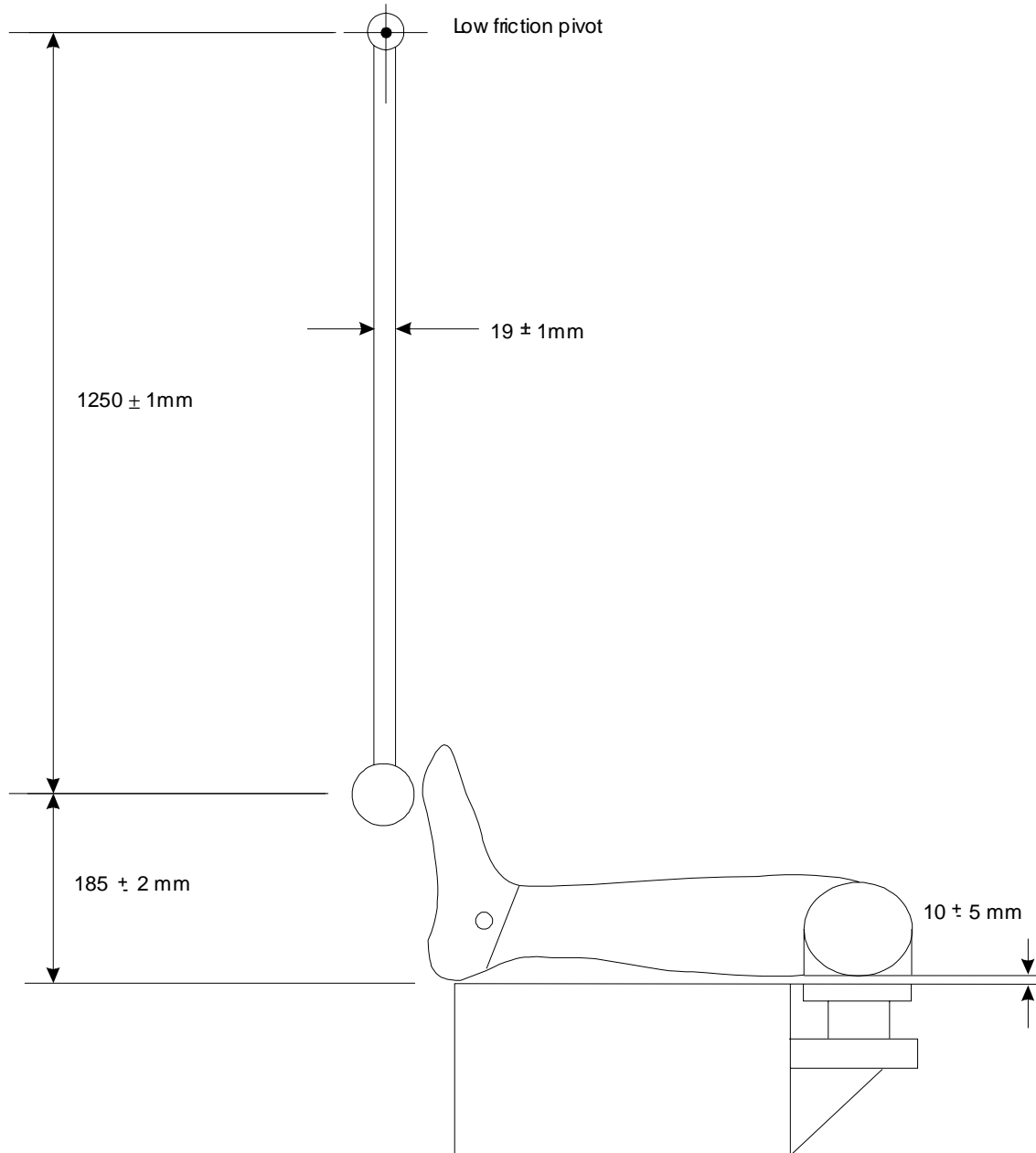

Figure 3
Lower foot impact test - test set-up specifications

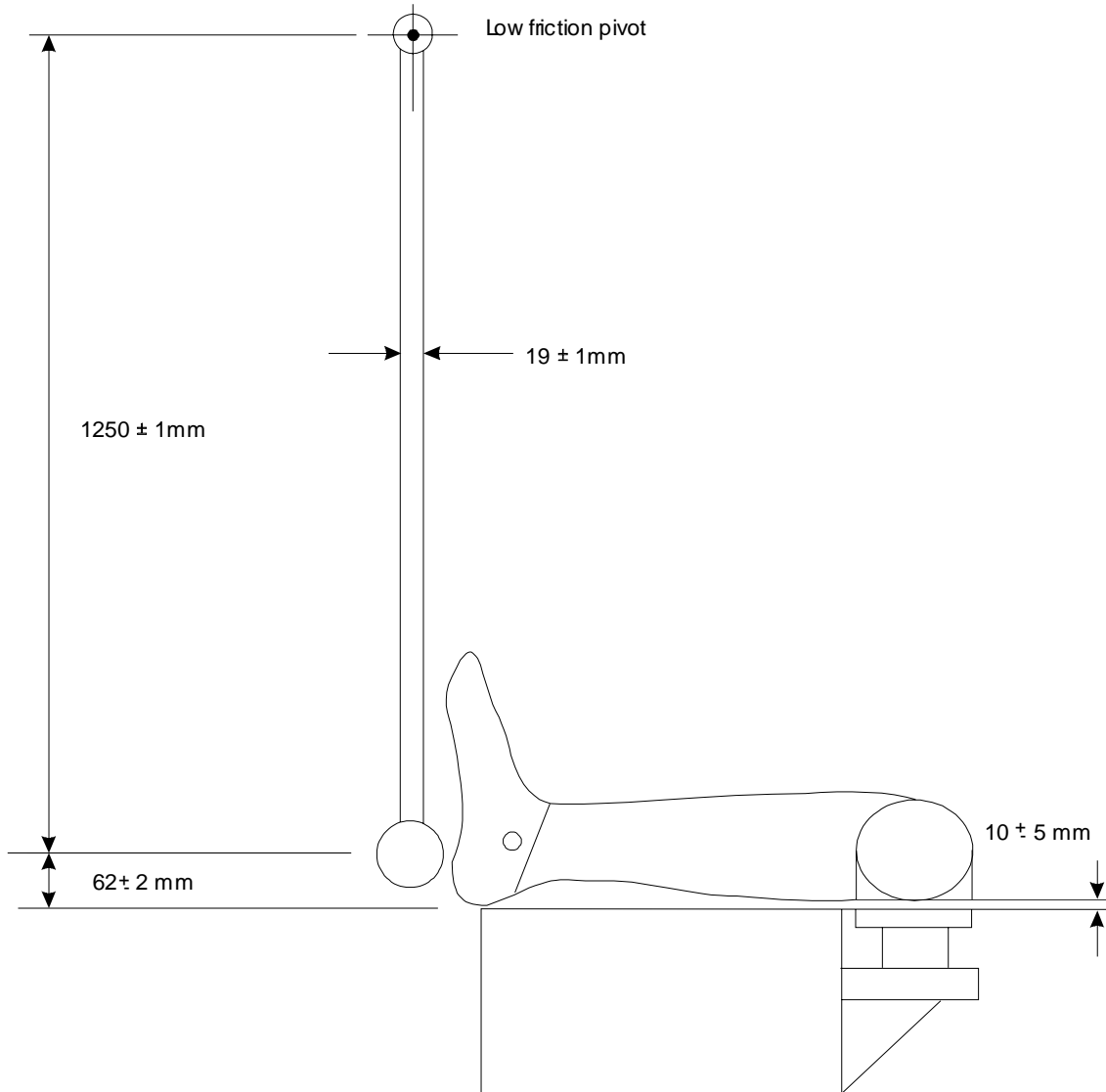

Figure 3a
Pendulum impactor

