



Vehicle Standard (Australian Design Rule 2/01 – Side Door Latches and Hinges) 2006

I, JAMES ERIC LLOYD, Minister for Local Government, Territories and Roads,
determine this vehicle standard under subsection 7 (1) of the *Motor Vehicle Standards
Act 1989*.

Dated 26 April 2006

[SIGNED]

James Eric Lloyd

Minister for Local Government, Territories and Roads

CONTENTS

1.	LEGISLATIVE PROVISIONS.....	3
2.	FUNCTION AND SCOPE.....	3
3.	APPLICABILITY	3
4.	DEFINITIONS	5
5.	REQUIREMENTS	5
6.	EXEMPTIONS AND ALTERNATIVE PROCEDURES	5
7.	ALTERNATIVE STANDARDS	5
	APPENDIX A	7

1. LEGISLATIVE PROVISIONS

1.1. Name of Standard

1.1.1. This Standard is the Vehicle Standard (Australian Design Rule 2/01 – Side Door Latches and Hinges) 2006.

1.1.2. This Standard may also be cited as Australian Design Rule 2/01 — Side Door Latches and Hinges.

1.2. Commencement

1.2.1. This Standard commences on the day after it is registered.

2. FUNCTION AND SCOPE

The function of this vehicle standard is to specify requirements for side door retention components including latches, hinges, and other supporting means to minimize the likelihood of occupants being thrown from a vehicle as a result of impact.

3. APPLICABILITY

This vehicle standard applies to the design and construction of LEP, LEG, MA, MB, MC and NA category vehicles from the dates set out in clauses 3.1, 3.2 and 3.5.

3.1. 1 July 2008 on all new model vehicles.

3.2. There is no mandatory application date for all other model vehicles. They may comply with this vehicle standard or continue to comply with earlier versions of this vehicle standard as applicable for particular vehicle categories.

3.3. For the purposes of clause 3.1 a "new model" is a vehicle model first produced with a '*Date of manufacture*' on or after the agreed date in clause 3.1.

3.4. LEP & LEG category vehicles must comply with M1 and N1 category vehicle requirements respectively.

3.5. Applicability Table

Vehicle Category	ADR Category Code	UNECE Category Code *	Manufactured on or After	Acceptable Prior Rules
Moped 2 wheels	LA	L1	N/A	
Moped 3 wheels	LB	L2	N/A	
Motor cycle	LC	L3	N/A	
Motor cycle and sidecar	LD	L4	N/A	
Motor tricycle	LE	L5		
	LEM		N/A	
Enclosed vehicles	LEP & LEG	(see clause 3.4)	1 July 2008	(see clause 3.2)
All vehicles	LEP & LEG	(see clause 3.4)	1 July 2008	(see clause 3.2)
Passenger car	MA	M1	1 July 2008	(see clause 3.2)
Forward-control passenger vehicle	MB	M1	1 July 2008	(see clause 3.2)
Off-road passenger vehicle	MC	M1	1 July 2008	(see clause 3.2)
Light omnibus	MD	M2	N/A	
up to 3.5 tonnes 'GVM' and up to 12 seats	MD1		N/A	
up to 3.5 tonnes 'GVM' and more than 12 seats	MD2		N/A	
over 3.5 tonnes and up to 4.5 tonnes 'GVM'	MD3		N/A	
over 4.5 tonnes and up to 5 tonnes 'GVM'	MD4		N/A	
Heavy omnibus	ME	M3	N/A	
Light goods vehicle	NA	N1	1 July 2008	(see clause 3.2)
Medium goods vehicle	NB	N2	N/A	
over 3.5 tonnes up to 4.5 tonnes 'GVM'	NB1		N/A	
over 4.5 tonnes up to 12 tonnes 'GVM'	NB2		N/A	
Heavy goods vehicle	NC	N3	N/A	
Very light trailer	TA	O1	N/A	
Light trailer	TB	O2	N/A	
Medium trailer	TC	O3	N/A	
Heavy trailer	TD	O4	N/A	

* The category code may also be in the format L₁, L₂, L₃ etc.

4. DEFINITIONS

- 4.1. For vehicle categories, definitions and meanings used in this standard, refer to:
- 4.2. Vehicle Standard (Australian Design Rule Definitions and Vehicle Categories) 2005; and
- 4.3. Definitions in Section 2 of Appendix A of this standard.

5. REQUIREMENTS

- 5.1. Vehicles subject to the requirements of this standard that are fitted with side doors must comply with the requirements of Appendix A, except as varied by Section 6 Exemptions and Alternative Procedures.

6. EXEMPTIONS AND ALTERNATIVE PROCEDURES

- 6.1. Compliance with the following parts, sections and annexes of Appendix A is not required for the purposes of this standard:
 - Section 3 Application for approval
 - Section 4 Approval
 - Section 7 Modifications and extension of approval of the vehicle type
 - Section 8 Conformity of production
 - Section 9 Penalties for non conformity of production
 - Section 10 Production definitely discontinued
 - Section 11 Names and addresses of technical services responsible for conducting approval tests and of administrative departments
 - Section 12 Transitional provisions

Annexes

Annex 1 Communication concerning the approval, the refusal of approval, the extension of approval, the approval withdrawn, the production definitely discontinued, of a vehicle type with regard to door latches and door retention components pursuant to Regulation No. 11

Annex 2 Arrangements of approval marks

7. ALTERNATIVE STANDARDS

- 7.1. The technical requirements adopted by the United Nations - Economic Commission for Europe Regulation No. 11 – UNIFORM PROVISIONS CONCERNING THE APPROVAL OF VEHICLES WITH REGARD TO DOOR LATCHES AND DOOR RETENTION COMPONENTS, incorporating the 02 series of amendments, shall be deemed to be equivalent to the technical requirements of this standard.
- 7.2. The technical requirements adopted by the United Nations - Economic Commission for Europe Global technical regulation No.1 – DOOR LOCKS AND

DOOR RETENTION COMPONENTS, shall be deemed to be equivalent to the technical requirements of this standard, provided the locking device described in clause 5.3.2. of that standard complies with 5.3.2.1.(a) or 5.3.2.1.(b) of that standard.

APPENDIX A
UNECE REGULATION NO 11/02
UNIFORM PROVISIONS CONCERNING THE APPROVAL OF VEHICLES WITH REGARD
TO DOOR LATCHES AND DOOR RETENTION COMPONENTS
INCORPORATING SUPPLEMENT 1 TO THE 02 SERIES OF AMENDMENTS

E/ECE/324
E/ECE/TRANS/505 Add.10/Rev.1
7 May 1981

AGREEMENT

CONCERNING THE ADOPTION OF UNIFORM CONDITIONS OF APPROVAL AND RECIPROCAL RECOGNITION OF APPROVAL FOR MOTOR VEHICLE EQUIPMENT AND PARTS

done at Geneva on 20 March 1958

Addendum 10: Regulation No. 11

**Date of entry into force as an annex to the Agreement.
1 June 1969**

Revision 1

Incorporating the 02 series of amendments which entered into force on 15 March 1981

**and incorporating by the Department of Transport and Regional Services:
Supplement 1 to the 02 series of amendments**

UNIFORM PROVISIONS CONCERNING THE APPROVAL OF VEHICLES WITH REGARD TO DOOR
LATCHES AND DOOR RETENTION COMPONENTS



UNITED NATIONS

Regulation No. 11UNIFORM PROVISIONS CONCERNING THE APPROVAL OF VEHICLES
WITH REGARD TO DOOR LATCHES AND
DOOR RETENTION COMPONENTS

CONTENTS

REGULATION

1. Scope
2. Definitions
3. Application for approval
4. Approval
5. Specifications
6. Tests
7. Modification of the vehicle type
8. Conformity of production
9. Penalties for non-conformity of production
10. Production definitely discontinued
11. Names and addresses of technical services responsible for conducting approval tests and administrative departments
12. Transitional provisions

ANNEXES

- Annex 1 - Communication concerning the approval (or refusal or withdrawal of approval or production definitely discontinued) of a vehicle type with regard to the door latches and door retention components pursuant to Regulation No. 11
- Annex 2 - Arrangements of approval marks
- Annex 3 - Test procedure for the door latches and door retention components

* * *

Regulation No. 11UNIFORM PROVISIONS CONCERNING THE APPROVAL OF VEHICLES
WITH REGARD TO DOOR LATCHES AND
DOOR RETENTION COMPONENTS

1. SCOPE

This Regulation applies to latches and door retention components such as hinges and other supporting means on side doors of vehicles of categories of M 1 and N 1 1/ used for, or which can be used for, the entry or exit of the occupants.

2. DEFINITIONS

For the purposes of this Regulation.

2.1 "Approval of a vehicle" means the approval of a vehicle type with regard to door latches and door retention components.

2.2. "Vehicle type" means a category of motor vehicles which do not differ in such essential respects as:

2.2.1. designation of the vehicle type by the manufacturer;

2.2.2. the type of latch;

2.2.3. the type of door retention component;

2.2.4. the way in which the latches and door retention components are fitted to and retained by the structure of the vehicle;

2.2.5. type of sliding doors;

2.3. "Doors" means hinged or sliding doors which lead directly into a compartment that contains one or more seating positions and which are not folding doors, roll-up doors and doors that are designed to be easily attached to or removed from motor vehicles manufactured for operation without doors.

3. APPLICATION FOR APPROVAL

3.1. The application for approval of a vehicle type with regard to door latches and door retention components shall be submitted by the vehicle manufacturer or by his duly accredited representative.

1/ As defined in Regulation No. 13

- 3.2 It shall be accompanied by the undermentioned documents in triplicate and the following particulars:
- 3.2.1. drawings of the doors and of their latches and door retention components on an appropriate scale and in sufficient detail;
- 3.2.2. a technical description of the latches and door retention components.
- 3.3. The application shall also be accompanied by:
- 3.3.1. A batch of five sets of retention components per door. When, however, the same sets are used for several doors, it will be sufficient to submit one batch of sets. Sets of door retention components which are distinguishable only because they are designed to be fitted on the left or on the right are not regarded as different;
- 3.3.2. A batch of five complete latches, including actuating mechanism, per door. When, however, the same complete latches are used for several doors, it will be sufficient to submit one batch of latches. Latches which are distinguishable only because they are designed to be fitted on the left or on the right are not regarded as different.
- 3.4. A vehicle, representative of the vehicle type to be approved, shall be submitted to the technical service responsible for conducting approval tests.
4. APPROVAL
- 4.1. If the vehicle type submitted for approval pursuant to this Regulation meets the requirements of paragraphs 5. and 6. below, approval of that vehicle type shall be granted.
- 4.2. An approval number shall be assigned to each type approved. Its first two digits (02) shall indicate the series of amendments incorporating the most recent major technical amendments made to the Regulation at the time of issue of the approval. The same Contracting Party may not assign the same number to the same vehicle type either if the doors are not equipped with latches or door retention components of the same type, or if the latches and door retention components are not fitted in the same manner as on the vehicle submitted for approval; on the other hand, it may assign the same number to another vehicle type whose doors are equipped with the same latches and door retention components fitted in the same manner as on the vehicle submitted for approval.

- 4.3. Notice of approval or of extension or refusal of approval of a vehicle type pursuant to this Regulation shall be communicated to the Parties to the Agreement applying this Regulation, by means of a form conforming to the model in annex 1 to this Regulation.
- 4.4. There shall be affixed, conspicuously and in a readily accessible place specified on the approval form, to every vehicle conforming to a vehicle type approved under this Regulation, an international approval mark consisting of:
- 4.4.1. a circle surrounding the letter "E" followed by the distinguishing number of the country which has granted approval; 1/
- 4.4.2. the number of this Regulation, followed by the letter "R", a dash and the approval number to the right of the circle described in paragraph 4.4.1.
- 4.5. If the vehicle conforms to a vehicle type approved, under one or more other Regulations annexed to the Agreement, in the country which has granted approval under this Regulation, the symbol prescribed in paragraph 4.4.1. need not be repeated; in such a case the Regulation and approval numbers and the additional symbols of all the Regulations under which approval has been granted in the country which has granted approval under this Regulation shall be placed in vertical columns to the right of the symbol prescribed in paragraph 4.4.1.
- 4.6. The approval mark shall be clearly legible and be indelible.

1/ 1 for the Federal Republic of Germany, 2 for France, 3 for Italy, 4 for the Netherlands, 5 for Sweden, 6 for Belgium, 7 for Hungary, 8 for Czechoslovakia, 9 for Spain, 10 for Yugoslavia, 11 for the United Kingdom, 12 for Austria, 13 for Luxembourg, 14 for Switzerland, 15 for the German Democratic Republic, 16 for Norway, 17 for Finland, 18 for Denmark, 19 for Romania, 20 for Poland and 21 for Portugal. Subsequent numbers shall be assigned to other countries in the chronological order in which they ratify the Agreement concerning the Adoption of Uniform Conditions of Approval and Reciprocal Recognition of Approval for Motor Vehicle Equipment and Parts, or in which they accede to that Agreement, and the numbers thus assigned shall be communicated by the Secretary-General of the United Nations to the Contracting Parties to the Agreement.

- 4.7. The approval mark shall be placed close to or on the vehicle data plate.
- 4.8. Annex 2 to this Regulation gives examples of arrangements of the approval marks.
5. SPECIFICATIONS
- 5.1 General specifications
- 5.1.1. Latches and door retention components on any side door leading directly into a compartment that contains one or more seating positions shall be so designed, constructed and fitted as to comply with the provisions of this Regulation.
- 5.1.2. Each latch shall have a fully latched position, for hinged doors, an intermediate latched position shall also be provided.
- 5.1.3. A sliding door which has no intermediate latched position shall automatically move away from the latch to a partially-opened position if the door has not reached the fully latched position, the partially-opened position shall be readily apparent to occupants of the vehicle.
- 5.1.4. Latches shall be designed in such a way as to prevent the doors opening accidentally.
- 5.1.5. The retention components of hinge-mounted side doors, other than folding doors, fitted to the sides of vehicles, shall be mounted at the forward edge in the direction of travel. In the case of double doors, this requirement shall apply to the door wing which opens first; the other wing shall be capable of being bolted.
- 5.2. Specifications concerning latches
- 5.2.1. Longitudinal load
The latch and striker assembly shall be capable of withstanding a longitudinal load of 444 daN in the intermediate latched position and 1,111 daN in the fully latched position (see annex 3, appendix, figure 2).
- 5.2.2. Transverse load
The latch and striker assembly shall be capable of withstanding a transverse load of 444 daN in the intermediate latched position, and 889 daN in the fully latched position (see annex 3, appendix, figure 3).
- 5.2.3. Resistance to inertia load
The latch shall not move from the fully latched position when an acceleration of 30 g is applied in both directions longitudinally and transversally to the latch, including its actuating mechanism,

with the locking mechanism disengaged.

5.3. Specifications for a set of retention components for each door

The set of retention components for each door shall be capable of supporting the door and withstanding a longitudinal load of 1,111 daN and a transverse load of 889 daN, in both directions.

5.4. Sliding doors

For sliding doors the track and slide combination or other supporting means shall not separate when an outward transverse load of 889 daN is applied to the load-bearing members at the opposite edges of the door (17.8 kN total). The test may be performed either in the vehicle or with the door retention components in a bench test fixture.

6. TESTS

Compliance with the provisions of paragraphs 5.1. to 5.4. above shall be checked in accordance with the methods set forth in annex 3 to this Regulation.

7. MODIFICATION AND EXTENSION OF APPROVAL OF THE VEHICLE TYPE

7.1. Every modification of the vehicle type shall be notified to the administrative department which approved the vehicle type. The department may then either:

7.1.1. consider that the modifications made are unlikely to have appreciable adverse effects and that in any case the vehicle still complies with the requirements; or

7.1.2. require a further test report from the technical service responsible for conducting the tests. Confirmation or refusal of approval, specifying the alterations, shall be communicated by the procedure specified in paragraph 4.3. above to the Parties to the Agreement which apply this Regulation.

7.3 The competent authority issuing the extension of approval shall assign a series number to each communication form drawn up for such an extension.

8. CONFORMITY OF PRODUCTION
 - 8.1. Every vehicle bearing an approval mark as prescribed under this Regulation shall conform to the vehicle type approved as regards features capable of modifying the characteristics of door latches and door retention components or the manner in which they are fitted.
 - 8.2. In order to verify conformity as prescribed in paragraph 8.1. above, a sufficient number of random checks shall be made on serially-manufactured vehicles bearing the approval mark required by this Regulation.
 - 8.3. As a general rule the checks as aforesaid shall be confined to the taking of measurements. However, if necessary, the latches and door retention components shall be subjected to tests referred to in paragraphs 5.2. and 5.3. above, selected by the technical service responsible for conducting approval tests.
9. PENALTIES FOR NON CONFORMITY OF PRODUCTION
 - 9.1. The approval granted in respect of a vehicle type pursuant to this Regulation may be withdrawn if the requirements laid down in paragraph 8.1. above are not complied with, or if the said latches and door retention components fail to pass the tests provided for in paragraph 8.2. above.
 - 9.2. If a Party to the Agreement which applies this Regulation withdraws an approval it has previously granted, it shall forthwith so notify the other Contracting Parties applying this Regulation, by means of a copy of the approval form bearing at the end, in large letters, the signed and dated annotation "APPROVAL WITHDRAWN".
10. PRODUCTION DEFINITELY DISCONTINUED

If the holder of the approval completely ceases to manufacture a type of vehicle under this Regulation, he shall so inform the authority which granted the approval. Upon receiving the relevant communication that authority shall inform thereof the other Parties to the Agreement applying this Regulation by means of a copy of the approval form bearing at the end, in large letters, the signed and dated annotation: "PRODUCTION DISCONTINUED".

11. NAMES AND ADDRESSES OF TECHNICAL SERVICES RESPONSIBLE FOR CONDUCTING APPROVAL TESTS AND OF ADMINISTRATIVE DEPARTMENTS

The Parties to the Agreement applying this Regulation shall communicate to the United Nations Secretariat the names and addresses of the technical services responsible for conducting approval tests and of the administrative departments which grant approval and to which forms certifying approval or refusal or withdrawal of approval, issued in other countries, are to be sent.

12. TRANSITIONAL PROVISIONS

Approvals granted under this Regulation amended by the 01 series of amendments (E/ECE/324-TRANS/505/Add.10, Corr.1 and Amend.1) shall cease to be valid two years after entry into force of the 02 series of amendments to this Regulation unless the Contracting Party which has granted the approval notifies the other Contracting Parties applying this Regulation that the vehicle type approved also meets the requirements of this Regulation as amended by the 02 series of amendments.

Annex 1

(Maximum format: A4 (210 x 297 mm))

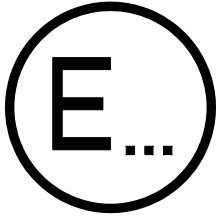

2/

Communication concerning: - the approval,
 - the refusal of approval,
 - the extension of approval,
 - the approval withdrawn,
 - the production definitely, discontinued.1/

of a vehicle type with regard to door latches and door retention
components pursuant to Regulation No. 11

Approval No.

Extension No

- 1. Trade name or mark of the motor vehicle:
- 2. Vehicle type:.....
- 3. Manufacturers name and address:
- 4. Name and address of the manufacturer's representative (if applicable):
- 5. Vehicle submitted for approval on:
- 6. Technical Service responsible for conducting approval tests:
- 7. Date of test report:
- 8. Number of test report:

- 9. Remarks:
 - the type of vehicle with the number of doors
 - (sedan 2 doors, 4 doors - station wagon 4 doors ...)
- 10. Position of approval mark:
- 11. Reason(s) of extension (if applicable):
- 12. Approval granted/refused/extended/withdrawn. 1/ :
- 13. Place:
- 14. Date:
- 15. Signature:
- 16. The list of documents deposited at the administrative service which has granted approval is annexed to this communication and available upon request.

1/ Strike out what does not apply.
2/ Name of the administration."

Annex 2

ARRANGEMENTS OF APPROVAL MARKS

Model A

(See paragraph 4.4. of this Regulation)

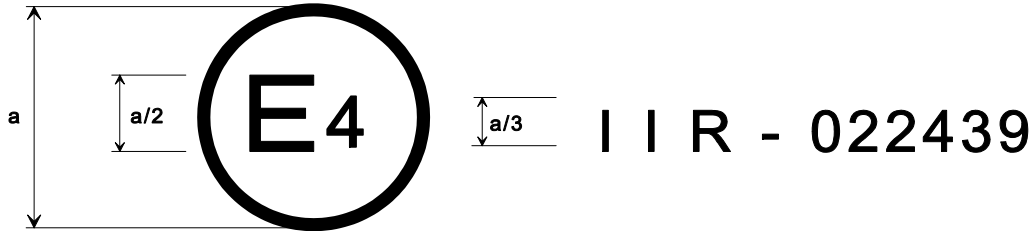

a = 8 mm min

The above approval mark affixed to a vehicle shows that the vehicle type concerned has, with regard to door latches and door retention components, been approved in the Netherlands (E 4) pursuant to Regulation No. 11, as amended by the 02 series of amendments.

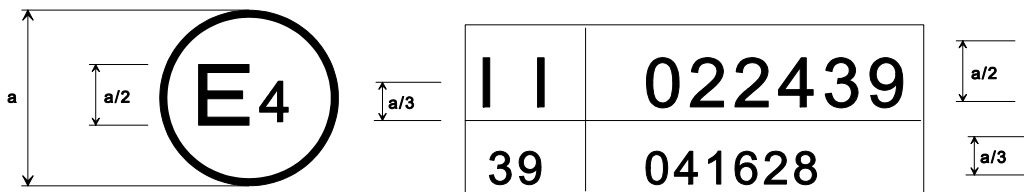

a = 8 mm min

Model B

(See paragraph 4.5. of this Regulation)

The above approval mark affixed to a vehicle shows that the vehicle type concerned has been approved in the Netherlands (E 4) pursuant to Regulation No.11 as amended by the 02 series of amendments and Regulation No. 39, as amended by the 04 series of amendments. 1/

1/ The second number is given merely as an example.

Annex 3

TEST PROCEDURE FOR DOOR LATCHES AND DOOR RETENTION COMPONENTS

1. GENERAL SPECIFICATIONS
 - 1.1. Test fixtures shall be sufficiently stiff to prevent localized stresses to the door retention components or to the latches during tests.
 - 1.2. The means of attachment of the sample to the test fixture shall be adequate to prevent failure to the attachment.
 - 1.3. The means of attachment of the sample to the test fixture shall be the same as or be equivalent to the means used in normal production for attaching components to the vehicle.
 - 1.4. The test system's overall accuracy shall be capable of providing data accurate to within ± 11.2 daN at 1,111 daN and ± 8.9 daN at 889 daN.
 - 1.5. Continuous recordings of applied load may be made during all tests. This does not include the 89 daN weight load on latches during longitudinal loading.
 - 1.6. The tensile force shall be applied at a rate not to exceed 5 mm per minute until the required test load is reached.
 - 1.7. A new set of devices being tested shall be used for each test.
2. TEST PROCEDURE FOR A SET OF RETENTION COMPONENTS FOR ONE DOOR
 - 2.1. LONGITUDINAL LOAD
 - 2.1.1. The set of retention components for one door shall be positioned on the test fixture in the closed-door attitude (see appendix, figure 1, to this annex).
 - 2.1.2. Full-length (piano) hinge: The hinge is positioned on the test fixture which shall have adequate dimensions to enable the hinge to be fitted along all its length to satisfy the following requirements:
 - 2.1.2.1. the line of application of tensile force shall bisect at right angles the engaged portion of the hinge pin;
 - 2.1.2.2. the tensile force, when applied, shall stress the hinge system approximately in the vehicle longitudinal direction.
 - 2.1.3. Multiple hinges: The hinge assemblies shall be positioned on the test fixture to satisfy the following requirements:
 - 2.1.3.1. the hinge pins shall be in a straight line, so that the prescribed longitudinal load is perpendicular to the axis of the hinge pivots, situated in a plane passing through that axis;
 - 2.1.3.2. the distance between further ends of adjacent hinges shall be 406 mm. For the case in which the 406 mm dimension cannot be complied with, the hinges shall be arranged in such a way that the distance between the nearest parts of two adjacent hinges shall be at least 100 mm;

- 2.1.3.3. a line joining the mid-points of the engaged portions of the two outermost hinge pins shall be bisected at right angles by the line of application of tensile force;
- 2.1.3.4. the tensile force, when applied, will stress the set of hinges approximately in the vehicle-longitudinal direction.
- 2.1.4. The set of hinges shall be attached to the test fixture as positioned in the previous applicable provision.
- 2.2 TRANSVERSE LOAD
 - 2.2.1. The set of hinges shall be positioned on the test fixture in the closed-door attitude (see appendix, figure 1 to this annex).
 - 2.2.2. Full-length (piano) hinge: The hinge is positioned on the test fixture which shall have adequate dimensions to enable the hinge to be fitted along all its length to satisfy the following requirements:
 - 2.2.2.1. the engaged length of the hinge pin shall be bisected at the right angles by the line of application of the tensile force;
 - 2.2.2.2. the hinge assembly shall be stressed approximately in the vehicle transverse direction.
 - 2.2.3. Multiple hinges: The hinge assemblies shall be positioned on the test fixture to satisfy the following requirements:
 - 2.2.3.1. the hinge pins shall be in a straight line, so that the prescribed transverse load is perpendicular to the plane defined by the longitudinal load and the axis of the pivots, and situated in a plane passing through the axis;
 - 2.2.3.2. the distance between further ends of adjacent hinges shall be 406 mm. For the case in which the 406 mm dimension cannot be complied with, the hinges shall be arranged in such a way that the distance between the nearest parts of two adjacent hinges shall be at least 100 mm;
 - 2.2.3.3. a line joining the mid-points of the engaged portions of the two outermost hinge pins shall be bisected at right angles by the line of application of tensile force;
 - 2.2.3.4. the tensile force, when applied, will stress the set of hinges approximately in the vehicle transverse direction.
 - 2.2.4. The hinge system shall be attached to the test fixture as positioned in the previous applicable provision.
 - 2.2.5. Sliding-doors: Conformity with paragraph 5.4. of this Regulation is verified by applying the total force of 1,778 daN to all points of attachment between the door and the structure by means of a rigid frame, the force being applied to the centre area of the surface determined by the polygon having as its extremities the said points of attachment.

LATCH SYSTEM, DETAILED TEST PROCEDURE

3.1. LONGITUDINAL LOAD, SECONDARY LATCHING

3.1.1. The latch and striker shall be positioned on the test fixture to satisfy the following requirements (see appendix, figure 2, to this annex).

3.1.1.1. the tensile force shall be in line with the contacting surfaces of the latch and striker;

3.1.1.2. the tensile force shall stress the latch and striker in the vehicle longitudinal direction.

3.1.2. The latch and striker shall be engaged in the secondary latched position.

3.1.3. A weight of 89 daN shall be applied to the latch, to load the latch and striker in the vehicle-transverse, door-opening direction.

3.2. LONGITUDINAL LOAD, FULL LATCHING

3.2.1. The latch and striker shall be positioned on the test fixture to satisfy the following requirements (see appendix, figure 2, to this annex).

3.2.1.1. the tensile force shall be in line with the contacting surfaces of the latch and striker;

3.2.1.2. the tensile force shall stress the latch and striker in the vehicle longitudinal direction.

3.2.2. The latch and striker shall be engaged in the fully latched position.

- 3.2.3. A weight of 89 daN shall be applied to the latch and striker in the vehicle-transverse, door-opening direction.
- 3.3. TRANSVERSE LOAD, SECONDARY LATCHING
- 3.3.1. The latch and striker shall be positioned on the test fixture to satisfy the following requirements (see appendix, figure 3, to this annex):
- 3.3.1.1. the tensile force shall be in line with the contacting surfaces of the latch and striker;
- 3.3.1.2. this tensile force shall stress the latch and striker in a direction that is approximately horizontal and transverse to the vehicle in the door-opening direction.
- 3.3.2. The latch and striker shall be engaged in the secondary latched position.
- 3.4. TRANSVERSE LOAD, FULL LATCHING
- 3.4.1. The latch and striker shall be positioned on the test fixture to satisfy the following requirements (see appendix, figure 3, to this annex):
- 3.4.1.1. the tensile force shall be in line with the contacting surfaces of the latch and striker;
- 3.4.1.2. this tensile force, when applied, shall stress the latch and striker in the vehicle-transverse, door-opening direction.
- 3.4.2. The latch and striker shall be engaged in the fully latched position.
- 3.5. PROCEDURE FOR DETERMINING THE RESISTANCE OF LATCHES TO ACCELERATION
- 3.5.1. Impact test
- 3.5.1.1. The resistance of door locks to inertia loads may be determined either by dynamic or by analytical means. In the case of a dynamic test, the test vehicle itself or the simulated structure shall be secured to a chassis with the door lock system in the fully latched position. An acceleration of 30-36 g, shall be applied to the chassis for a period of at least 30 milliseconds in a forward direction in parallel to the vehicle longitudinal axis as well as in a direction of the door opening that is perpendicular to the above described first direction.
- 3.5.1.2. When equipped with a lock device (a device to secure the latch and striker in a locked position), ensure that the device does not come into action during the tests.

3.5.1.3. The instrumentation shall permit the recording of the acceleration value without distortion for the phenomena having frequencies up to 100 hertz, the permissible distortion being:

+05		+05
	Db to 60 Hz and	Db to 100 Hz. <u>1/</u>
- 1		- 4

EQUIVALENT TEST METHODS

4.1. Equivalent non-destructive test methods are permitted, provided that the results referred to in paragraph 5. of the Regulation can be obtained either entirely by means of the substitute test or by calculation from the results of the substitute test. An example of calculation is reproduced in appendix, figure 4, to this annex. If a method other than that described in paragraphs 2. and 3. above is used, its equivalence shall be demonstrated.

1/ Corresponding to Class 60 of ISO DIS 6487 "Road vehicles. Technics of measurement in impact tests. Instrumentation.

Annex 3 - Appendix

Fig. 1 - DOOR RETENTION COMPONENTS - STATIC LOAD
FIXTURE (TRANSVERSE LOAD)

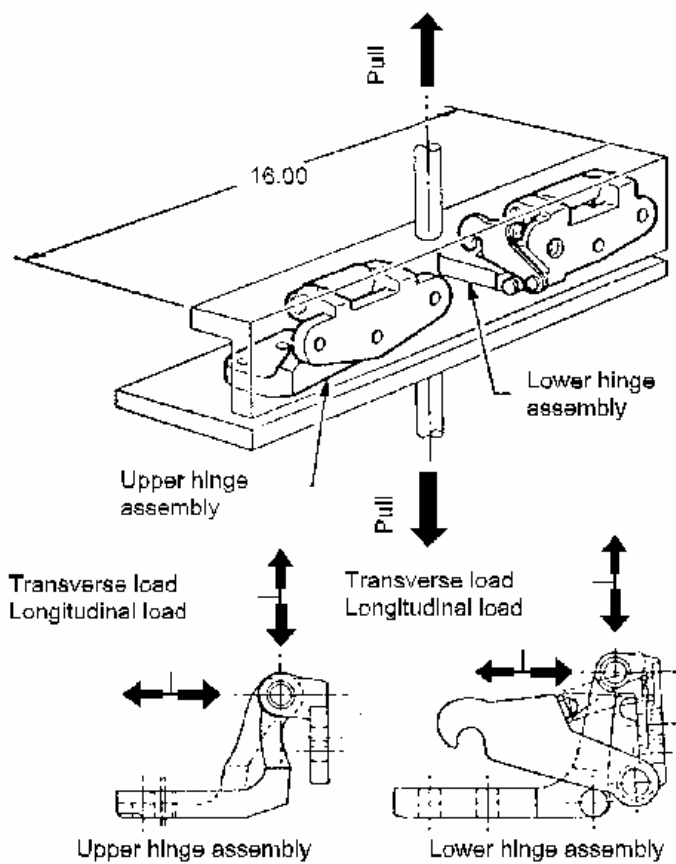

Annex 3 - Appendix

Fig. 2 - DOOR LATCH - TEST EQUIPMENT UNDER STATIC LOAD
(LONGITUDINAL LOAD)

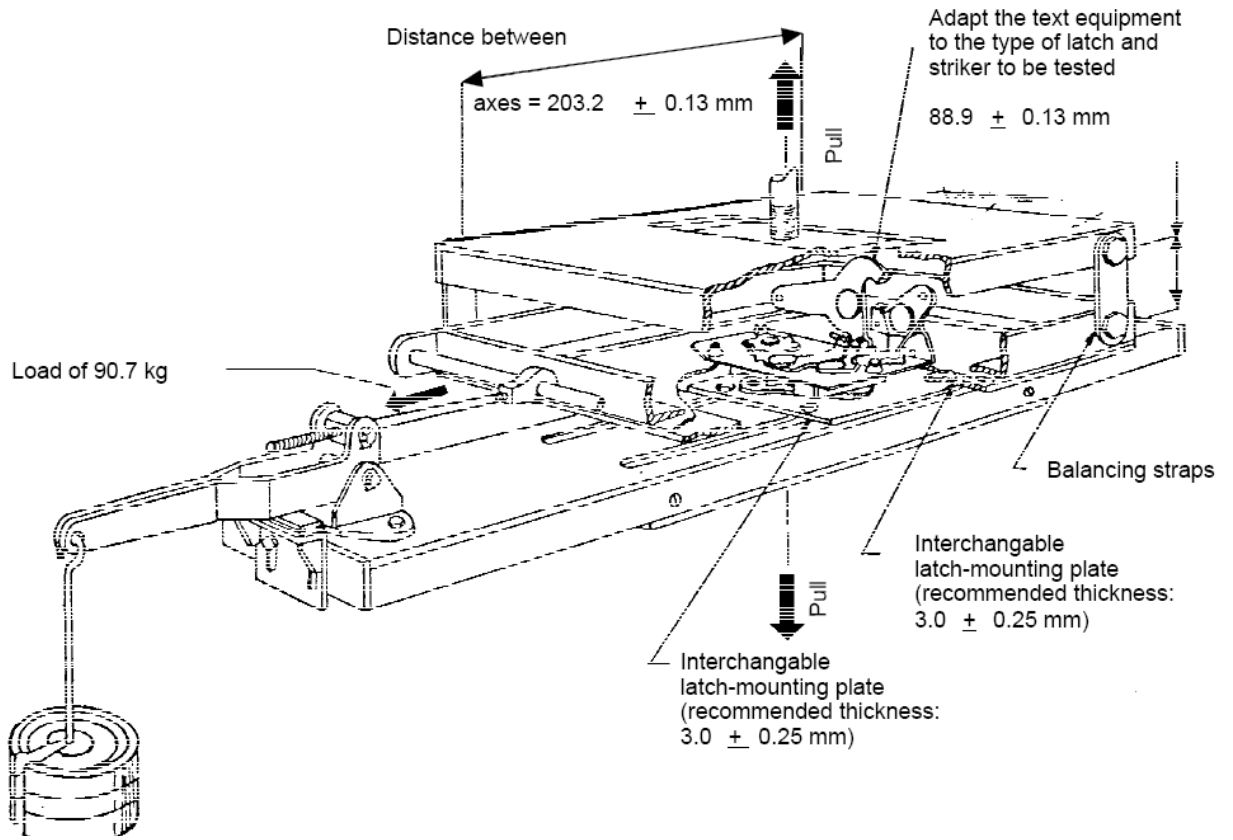

FIG. 3 - DOOR LATCHES - TEST EQUIPMENT UNDER STATIC LOAD
(TRANSVERSE LOAD)

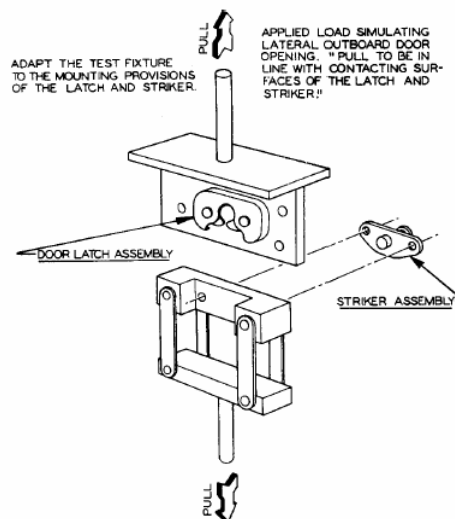
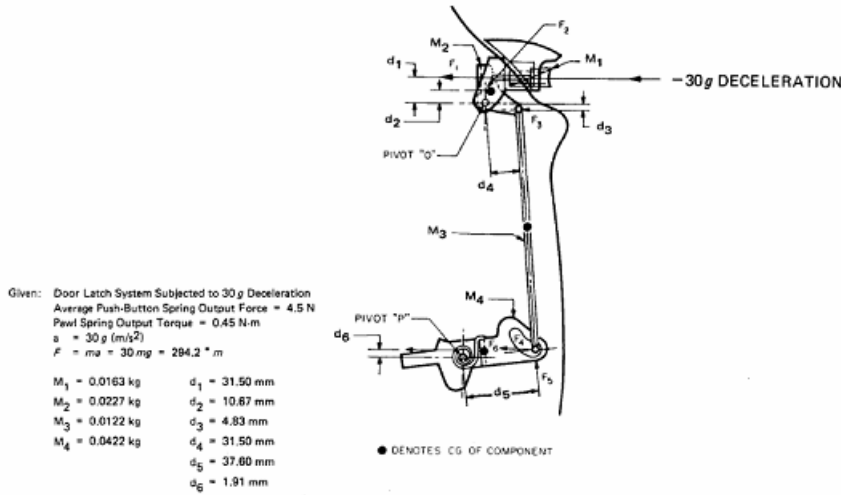

FIG. 4 - RESISTANCE TO THE EFFECTS OF INERTIA EXAMPLE OF CALCULATION



Given: Door Latch System Subjected to 30g Deceleration
 Average Push-Button Spring Output Force = 4.5 N
 Pawl Spring Output Torque = 0.45 N-m
 $a = 30g$ (m/s^2)
 $F = ma = 30mg = 294.2 \text{ N}$

- $M_1 = 0.0163 \text{ kg}$ $d_1 = 31.50 \text{ mm}$
- $M_2 = 0.0227 \text{ kg}$ $d_2 = 10.67 \text{ mm}$
- $M_3 = 0.0122 \text{ kg}$ $d_3 = 4.83 \text{ mm}$
- $M_4 = 0.0422 \text{ kg}$ $d_4 = 31.50 \text{ mm}$
- $d_5 = 37.60 \text{ mm}$
- $d_6 = 1.91 \text{ mm}$

$$F_1 = M_1 a \text{ (avg. spring output)} = (0.0163 \times 294.2) - 4.5 = 0.30 \text{ N}$$

$$F_2 = M_2 a = 0.0227 \times 294.2 = 6.68 \text{ N}$$

$$F_3 = \frac{M_3 a}{2} = (0.0122/2) \times 294.2 = 1.80 \text{ N}$$

$$\Sigma M_o = F_1 \times d_1 + F_2 d_2 - F_3 d_3 = 0.30 \times 31.5 + 6.68 \times 10.67 - 1.80 \times 4.83 = 72.0 \text{ N}\cdot\text{mm}$$

$$F_6 = \frac{M_o}{d_4} = \frac{72.0}{31.50} = 2.30 \text{ N}$$

$$F_6 = M_4 a = 0.0422 \times 294.2 = 12.42 \text{ N}$$

$$\Sigma M_p = \text{(pawl spring output)} \cdot \left(\frac{F_6 \times d_5 + F_6 \times d_6}{1000} \right) = 0.45 \cdot \left(\frac{2.30 \times 37.60 + 12.42 \times 1.91}{1000} \right) = 0.34 \text{ N}\cdot\text{m}$$

EQUATIONS

SYMBOL	DEFINITION
m	Mass
a	Acceleration
g	Gravitational Acceleration
d	Distance to Pivot
F	Force
M	Moment About a Point

METRIC UNITS

SYMBOL	DEFINITION
kg	Kilogram
m/s^2	Meter per second squared
m/s^2	9.806 650 Meter per second squared
mm	Millimeter
N	Newton
N-m	Newton Meter (preferred)
N-mm	(Newton-Millimeter)