



## **Vehicle Standard (Australian Design Rule 47/00 – Retroreflectors) 2006**

I, JAMES ERIC LLOYD, Minister for Local Government, Territories and Roads,  
determine this vehicle standard under subsection 7 (1) of the *Motor Vehicle Standards  
Act 1989*.

Dated            26 April 2006

[SIGNED

James Eric Lloyd

Minister for Local Government, Territories and Roads

**CONTENTS**

0.1. NAME OF STANDARD ..... 3

0.2. COMMENCEMENT..... 3

0.3. REPEAL..... 3

1. SCOPE..... 3

2. APPLICABILITY AND IMPLIMENTATION ..... 3

3. DEFINITIONS ..... 3

4. REQUIREMENTS ..... 3

5. EXEMPTIONS AND ALTERNATIVE PROCEDURES ..... 3

6. SUPPLEMENTARY GENERAL REQUIREMENTS ..... 4

7. ALTERNATIVE STANDARDS ..... 4

8. NOTES ..... 4

APPENDIX A ..... 5

**0.1. NAME OF STANDARD**

- 0.1.1. This Standard is the Vehicle Standard (Australian Design Rule 47/00 – Retroreflectors) 2006.
- 0.1.2. This Standard may also be cited as Australian Design Rule 47/00 — Retroreflectors.

**0.2. COMMENCEMENT**

- 0.2.1. This Standard commences on the day after it is registered.

**0.3. REPEAL**

- 0.3.1. This Standard repeals each vehicle standard with the name Australian Design Rule 47/00 — Retroreflectors that is:
- (a) made under section 7 of the Motor Vehicles Standard Act 1989; and
  - (b) in force at the commencement of this Standard.
- 0.3.2. This Standard also repeals each instrument made under section 7 of the Motor Vehicles Standard Act 1989 that creates a vehicle standard with the name Australian Design Rule 47/00 — Retroreflectors, if there are no other vehicle standards created by that instrument, or amendments to vehicle standards made by that instrument, that are still in force at the commencement of this Standard.

**1. SCOPE**

This Australian Design Rule (ADR) prescribes the dimensions, photometric and stability requirements for retroreflecting devices which when mounted on a vehicle will ensure that they effectively warn of the presence of the vehicle.

**2. APPLICABILITY AND IMPLEMENTATION**

- 2.1. The circumstances under which retroreflectors are mandatory, optional, or prohibited are set out in either ADRs 13/..., 19/... or 67/....

**3. DEFINITIONS**

- 3.1. Refer to paragraph 2 of Appendix A.

**4. REQUIREMENTS**

- 4.1. Devices complying with the technical requirements of Appendix A as varied by part 5 Exemptions and Alternative Procedures and part 6 Supplementary General Requirements shall be accepted as complying with this rule.

**5. EXEMPTIONS AND ALTERNATIVE PROCEDURES**

- 5.1. The following provisions of Appendix A do not apply to this rule:
- 5.1.1. Section 3 Application for approval

Section 4	Markings
Section 5	Approval
Section 7	Special specifications (tests)
Section 9	Penalties for non conformity of production
Section 10	Production definitely discontinued
Section 11	Names and addresses of technical services responsible for conducting approval tests, and of administrative departments
Section 12	Transitional provisions
Annexes	
Annex 2	Communication concerning the approval (or refusal or withdrawal of approval or production definitely discontinued) of a type of reflex reflecting device pursuant to Regulation No. 3
Annex 3	Arrangements of approval marks
Annex 5	Appendix – Retroreflectors for trailers – Class IIIA
Annex 13	Resistance to impact
Annex 14	Test procedure – Class IVA
Annex 15	Chronological order of tests for Class IVA

5.1.2. Paragraphs 2.3 and 3.3 in Annex 18.

## **6. SUPPLEMENTARY GENERAL REQUIREMENTS**

The following general requirements are supplementary to the requirements of Appendix A:

6.1. The requirements and procedures set out in Annexes 17 and 18 of Appendix A are acceptable for the purposes of demonstrating compliance with the technical requirements of this rule

## **7. ALTERNATIVE STANDARDS**

7.1. The technical requirements of any of the editions of United Nations Economic Commission for Europe (UN ECE) Regulation No. 3 UNIFORM PROVISIONS CONCERNING THE APPROVAL OF RETRO-REFLECTING DEVICES FOR POWER DRIVEN VEHICLES AND THEIR TRAILERS. incorporating the 02 series of amendments are deemed to be equivalent to the technical requirements of this rule.

## **8. NOTES**

8.1. In place of Regulation No 48 where referenced in Appendix A, read ADR 13/00.

8.2. In place of Regulation No 37 where referenced in Appendix A, read ADR 51/00.

**APPENDIX A**

**UN-ECE REGULATION NO. 3/02  
UNIFORM PROVISIONS CONCERNING THE APPROVAL OF  
RETROREFLECTING DEVICES  
FOR POWER DRIVEN VEHICLES AND TRAILERS**

### **Regulation No. 3**

## **UNIFORM PROVISIONS CONCERNING THE APPROVAL OF RETRO-REFLECTING DEVICES FOR POWER-DRIVEN VEHICLES AND TRAILERS**

### **CONTENTS**

#### **REGULATION**

1. Scope
2. Definitions
3. Application for approval
4. Markings
5. Approval
6. General specifications
7. Special specifications (tests)
8. Conformity of production
9. Penalties for non-conformity of production
10. Production definitely discontinued
11. Names and address of technical services responsible for conducting approval tests, and of administrative departments
12. Transitional provisions

#### **ANNEXES**

- Annex 1- Retro-reflecting devices, symbols, units
- Annex 2- Communication concerning the approval (or refusal or withdrawal of approval or production definitely discontinued) of a type of retro-reflecting device pursuant to Regulation No. 3
- Annex 3- Arrangements of approval marks
- Annex 4- Test procedure - Class IA and Class IIIA
- Annex 5- Specifications of shape and dimensions
- Annex 5- Appendix - Retroreflectors for trailers - Class III A
- Annex 6- Colorimetric specifications
- Annex 7- Photometric specifications
- Annex 8- Resistance to external agents
- Annex 9- Stability in time of optical properties of retro-reflecting devices
- Annex 10- Resistance to heat
- Annex 11- Colour fastness
- Annex 12- Chronological order of tests
- Annex 13- Resistance to impact - Class IV A
- Annex 14- Test procedure - Class IV A
- Annex 15- Chronological order of tests for Class IV A
- Annex 16- Test procedure for Class IB devices
- Annex 17- Minimum requirements for conformity of production control procedures
- Annex 18- Minimum requirements for sampling by an inspector

### **Regulation No. 3**

## **UNIFORM PROVISIONS CONCERNING THE APPROVAL OF RETRO-REFLECTING DEVICES FOR POWER-DRIVEN VEHICLES AND TRAILERS**

### **1. SCOPE**

This Regulation applies to retro-reflecting devices <sup>1/</sup> used on road vehicles.

### **2. DEFINITIONS <sup>2/</sup>**

For the purpose of this Regulation,

- 2.1. The definitions given in Regulation No. 48 and its series of amendments in force at the time of application for type approval shall apply to this Regulation.
- 2.2. "Retroreflection" means the reflection in which light is reflected in directions close to the direction from which it came. This property is maintained over wide variations of the illumination angle.
- 2.3. "Retro-reflecting optical unit" means a combination of optical components producing retroreflection.
- 2.4. "Retro-reflecting device" / means an assembly ready for use and comprising one or more retro-reflecting optical units.
- 2.5. "Angle of divergence" means the angle between the straight lines connecting the centre of reference to the centre of the receiver and to the centre of the source of illumination.
- 2.6. "Illumination angle" means the angle between the axis of reference and the straight line connecting the centre of reference to the centre of the source of illumination.
- 2.7. "Angle of rotation" means the angle through which the retro-reflecting device is rotated about its axis of reference starting from one given position.
- 2.8. "Angular diameter of the retro-reflecting device" means the angle subtended by the greatest dimension of the visible area of the illuminating surface, either at the centre of the source of illumination or at the centre of the receiver.
- 2.9. "Illumination of the retro-reflecting device" is the abbreviated expression used conventionally to designate the illumination measured in a plane perpendicular to the incident rays and passing through the centre of reference.
- 2.10. "Coefficient of luminous intensity (CIL)" means the quotient of the luminous intensity reflected in the direction considered, divided by the illumination of the retro-reflecting device for given angles of illumination, divergence and rotation.
- 2.11. The symbols and units used in this Regulation are given in annex 1 to this Regulation.

---

<sup>1/</sup> Also called "retroreflector(s)".

<sup>2/</sup> The definitions of the technical terms (excluding the ones in Regulation No. 48) are those adopted by the International Commission on Illumination (CIE).

- 2.12. A type of "retro-reflecting device" is defined by the models and descriptive literature submitted with the application for approval. Retro-reflecting devices can be considered as belonging to the same type if they have one or more "retro-reflecting optical units" which are identical with those of the standard model, or if not identical are symmetrical and suitable for mounting one on the left and one on the right side of the vehicle, and if their other parts differ from those of the standard model only in ways not affecting the properties to which this Regulation applies.
- 2.13. Retro-reflecting devices are divided into three classes according to their photometric characteristics: Class IA or IB, Class IIIA and Class IVA.
- 2.15. Retro-reflecting devices are divided into three classes according to their photometric characteristics: Class IA or IB, Class IIIA and Class IVA.
- 2.16. Retro-reflecting devices of Class IB are devices combined with other signal lamps which are not watertight according to annex 8, paragraph 1.1., and which are integrated into the body of a vehicle.

### **3. APPLICATION FOR APPROVAL**

- 3.1. The application for approval shall be submitted by the holder of the trade name or mark, or if necessary by his duly accredited representative, and shall be accompanied by:
- 3.1.1. drawings, in triplicate, in sufficient detail to permit identification of the type, showing geometrically the position in which the retro-reflecting device is to be fitted to the vehicle. The drawings must show the position intended for the approval number and class indicator in relation to the circle of the approval mark;
- 3.1.2. a brief description giving the technical specifications of the materials of which the retro- reflecting optical unit is made;
- 3.1.3. Samples of the retro-reflecting device of a colour specified by the manufacturer and, if necessary, the means of fixation; the number of samples to be submitted is specified in annex 4.
- 3.1.4. if necessary, two samples in other colour(s) for simultaneous or subsequent extension of the approval to devices in other colour(s).
- 3.1.5. In the case of devices of Class IV A: samples of the retro-reflecting device and, if necessary, the means of fixation; the number of samples to be submitted is specified in annex 14 to this Regulation.

### **4. MARKINGS**

- 4.1. Every retro-reflecting device submitted for approval must bear:
- 4.1.1. the trade name or mark of the applicant;
- 4.1.2. the word "TOP" inscribed horizontally on the highest part of the illuminating surface, if such an indication is necessary to determine without ambiguity the angle or angles of rotation prescribed by the manufacturer.
- 4.2. A space of sufficient size to accommodate the approval mark shall be provided on every device. This space shall be shown on the drawings referred to in paragraph 3.1.1. above.



4.3. The markings must be applied on the illuminating surface, or on one of the illuminating surfaces, of the retro-reflecting device and must be visible from the outside when the retro-reflecting device is fitted on the vehicle.

4.4. The markings must be clearly legible and be indelible.

## 5. APPROVAL

5.1. If all the samples submitted meet the requirements of this Regulation, approval shall be granted.

5.2. If the approval granted in respect of a retro-reflecting device is extended to other such devices differing only in colour, the two samples in any other colour submitted in conformity with paragraph 3.1.4. of this Regulation shall be required to meet only the colorimetric specifications (annex 6), the other tests no longer being required. Paragraph 5.2. is not applicable to devices of Class IV A.

5.3. An approval number shall be assigned to each type approved. Its first two digits (at present 02, corresponding to the 02 series of amendments which entered into force on 1 July 1985) shall indicate the series of amendments incorporating the most recent major technical amendments made to the Regulation at the time of issue of the approval. The same Contracting Party shall not assign the same number to another type of retro-reflecting device covered by this Regulation except in the case of an extension of the approval to a device differing only in colour.

5.4. Notice of approval or of extension or refusal of approval of a type of retro-reflecting device pursuant to this Regulation shall be communicated to the Parties to the Agreement which apply this Regulation, by means of a form conforming to the model in annex 2 to this Regulation.

5.5. There shall be affixed to every retro-reflecting device conforming to a type approved under this Regulation, in the space referred to in paragraph 4.2. above and in addition to the markings prescribed in paragraph 4.1.

5.5.1. an international approval mark consisting of:

5.5.1.1. a circle surrounding the letter "E" followed by the distinguishing number of the country which has granted approval;<sup>3/</sup>

5.5.1.2. an approval number;

5.5.1.3. a group of symbols IA, IB, IIIA or IVA showing the class of the approved retro-reflecting device.

---

<sup>3/</sup> 1 for Germany, 2 for France, 3 for Italy, 4 for the Netherlands, 5 for Sweden, 6 for Belgium, 7 for Hungary, 8 for Czech Republic, 9 for Spain, 10 for Yugoslavia, 11 for the United Kingdom, 12 for Austria, 13 for Luxembourg, 14 for Switzerland, 15 (vacant), 16 for Norway, 17 for Finland, 18 for Denmark, 19 for Romania, 20 for Poland and 21 for Portugal, 22 for the Russian Federation, 23 for Greece, 24 (vacant), 25 for Croatia, 26 for Slovenia, 27 for Slovakia, 28 for Belarus, 29 for Estonia, 30 (vacant), 31 for Bosnia and Herzegovina, 32-36 (vacant), 37 for Turkey, 38-39 (vacant) and 40 for The former Yugoslav Republic of Macedonia. Subsequent numbers shall be assigned to other countries in the chronological order in which they ratify or accede to the Agreement Concerning the Adoption of Uniform Technical Prescriptions for Wheeled Vehicles, Equipment and Parts which can be Fitted and/or be Used on Wheeled Vehicles and the Conditions for Reciprocal Recognition of Approvals Granted on the Basis of these Prescriptions, and the numbers thus assigned shall be communicated by the Secretary-General of the United Nations to the Contracting Parties to the Agreement.

- 5.6. When two or more lamps are part of the same unit of grouped, combined or reciprocally incorporated lamps (including a retroreflector), approval is granted only if each of these lamps satisfies the requirements of this Regulation or of another Regulation. Lamps not satisfying any one of those Regulations shall not be part of such a unit of grouped, combined or reciprocally incorporated lamps.
- 5.6.1. Where grouped, combined or reciprocally incorporated lamps comply with the requirements of several Regulations, a single international approval mark may be applied, consisting of a circle surrounding the letter "E" followed by the distinguishing number of the country which has granted the approval, an approval number and, if necessary, the required arrow. This approval mark may be placed anywhere on the grouped, combined or reciprocally incorporated lamps provided that:
- 5.6.1.1. It is visible after their installation;
- 5.6.1.2. No part of the grouped, combined or reciprocally incorporated lamps that transmits light can be removed without at the same time removing the approval mark.
- 5.6.2. The identification symbol for each lamp appropriate to each Regulation under which approval has been granted, together with the corresponding series of amendments incorporating the most recent major technical amendments to the Regulation at the time of issue of the approval, shall be marked:
- 5.6.2.1. Either on the appropriate light-emitting surface,
- 5.6.2.2. Or in a group, in such a way that each lamp of the grouped, combined or reciprocally incorporated lamps may be clearly identified (see three possible examples shown in annex 3).
- 5.6.3. The size of the components of a single approval mark shall not be less than the minimum size required for the smallest of the individual marks by a Regulation under which approval has been granted.
- 5.6.4. An approval number shall be assigned to each type approved. The same Contracting Party may not assign the same number to another type of grouped, combined or reciprocally incorporated lamps covered by this Regulation.
- 5.7. The approval mark must be clearly legible and be indelible.
- 5.8. Annex 3 to this Regulation gives examples of arrangements of approval marks for a single lamp (figure 1) and for grouped, combined or reciprocally incorporated lamps (figure 2) with all the additional symbols referred to above.

## **6. GENERAL SPECIFICATIONS**

- 6.1. Retro-reflecting devices must be so constructed that they function satisfactorily and will continue to do so in normal use. In addition, they must not have any defect in design or manufacture that is detrimental to their efficient operation or to their maintenance in good condition.

- 6.2. The components of retro-reflecting devices must not be capable of being easily dismantled.
- 6.3. Retro-reflecting optical units may not be replaceable.
- 6.4. The outer surface of retro-reflecting devices must be easy to clean. Hence it must not be a rough surface; any protuberances it may exhibit must not prevent easy cleaning.
- 6.5. For devices of Class IV A their means of fixation shall be such that they allow a stable and durable connection between the device and the vehicle.
- 6.6. There shall be no access to the inner surface of the retro-reflectors when in normal use.

## **7. SPECIAL SPECIFICATIONS (TESTS)**

- 7.1. Retro-reflecting devices must also satisfy the conditions as to dimensions and shape, and the colorimetric, photometric, physical and mechanical requirements set forth in annexes 5 to 11 and 13 to this Regulation. The test procedures are described in annex 4 (Class IA, IIIA), annex 14 (Class IVA) and annex 16 (Class IB).
- 7.2. Depending on the nature of the materials of which the retro-reflecting devices and, in particular, their optical units, are made, the competent authorities may authorize laboratories to omit certain unnecessary tests, subject to the express reservation that such omission must be mentioned under "Remarks" on the form notifying approval.

## **8. CONFORMITY OF PRODUCTION**

The conformity of production procedures shall comply with those set out in the Agreement, Appendix 2 (E/ECE/324-E/ECE/TRANS/505/Rev.2), with the following requirements:

- 8.1. Retro-reflectors approved under this Regulation shall be so manufactured as to conform to the type approved by meeting the requirements set forth in paragraphs 6 and 7 above.
- 8.2. The minimum requirements for conformity of production control procedures set forth in annex 17 to this Regulation shall be complied with.
- 8.3. The minimum requirements for sampling by an inspector set forth in annex 18 to this Regulation shall be complied with.
- 8.4. The authority which has granted type approval may at any time verify the conformity control methods applied in each production facility. The normal frequency of these verifications shall be once every two years.

## **9. PENALTIES FOR NON-CONFORMITY OF PRODUCTION**

- 9.1. The approval granted for a type of retro-reflecting device may be withdrawn if the requirements are not complied with or if a retro-reflecting device bearing the approval mark does not conform to the type approved.
- 9.2. If a Contracting Party to the Agreement applying this Regulation withdraws an approval it has previously granted, it shall forthwith so notify the other Contracting Parties applying this Regulation by means of a communication form conforming to the model in annex 2 to this Regulation.

**10. PRODUCTION DEFINITELY DISCONTINUED**

If the holder of the approval completely ceases to manufacture a type of retro-reflecting device approved in accordance with this Regulation, he shall so inform the authority which granted the approval. Upon receiving the relevant communication, that authority shall inform thereof the other Parties to the 1958 Agreement applying this Regulation by means of a communication form conforming to the model in annex 2 to this Regulation.

**11. NAMES AND ADDRESSES OF TECHNICAL SERVICES RESPONSIBLE FOR CONDUCTING APPROVAL TESTS, AND OF ADMINISTRATIVE DEPARTMENTS**

The Contracting Parties to the Agreement which apply this Regulation shall communicate to the United Nations Secretariat the names and addresses of the technical services responsible for conducting approval tests and of the administrative departments which grant approval and to which forms certifying approval of extension or refusal or withdrawal of approval, issued in other countries, are to be sent.

**12. TRANSITIONAL PROVISIONS**

The Contracting Parties applying this Regulation:

- 12.1. Shall continue to recognize approvals issued for the former Classes I, II and III in respect of the fitting of retro-reflecting devices intended as replacement for vehicles in use;
- 12.2. May issue approvals for Classes I and II on the basis of original Regulation (document E/ECE/324-E/ECE/TRANS/505/Add.2 of 23 September 1964) provided that the devices are intended as replacements for fitting to vehicles in use and that it would not be technically feasible for the devices in question to satisfy the photometric requirements for Class I A;
- 12.3. May prohibit the fitting of retro-reflecting devices which do not meet the requirements of this Regulation;
  - 12.3.1. on vehicles for which type approval or individual approval was issued on or after 20 March 1984;
  - 12.3.2. on vehicles first brought into use on or after 20 March 1985.

## Annex 1

### RETRO-REFLECTING DEVICE

#### Symbols and units

A	=	Area of the illuminating surface of the retro-reflecting device (cm <sup>2</sup> )
C	=	Centre of reference
NC	=	Axis of reference
Rr	=	Receiver, observer or measuring device
Cr	=	Centre of receiver
Ør	=	Diameter of receiver Rr if circular (cm)
Se	=	Source of illumination
Cs	=	Centre of source of illumination
Øs	=	Diameter of source of illumination (cm)
De	=	Distance from centre Cs to center C (m)
D'e	=	Distance from centre Cr to center C (m)

**Note:** IN GENERAL, De and D'e are very nearly the same and under normal conditions of observation it may be assumed that De = D'e.

D	=	Observation distance from and from beyond which the illuminating surface appears to be continuous
α	=	Angle of divergence
β	=	Illumination angle. With respect to the line CsC which is always considered to be horizontal, this angle is prefixed by the signs - (left), + (right), + (up) or - (down), according to the position of the source Se in relation to the axis NC, as seen when looking towards the retro-reflecting device. For any direction defined by two angles, vertical and horizontal, the vertical angle is always given first.
γ	=	Angular diameter of the measuring device Rr as seen from point C
δ	=	Angular diameter of the source Se as seen from point C
ε	=	Angle of rotation. This angle is positive when the rotation is clockwise as seen when looking towards the illuminating surface. If the retro-reflecting device is marked "TOP", the position thus indicated is taken as the origin.
E	=	Illumination of the retro-reflecting device (lux)
CIL	=	Coefficient of luminous intensity (millicandelas/lux) Angles are expressed in degrees and minutes.

**RETROREFLECTORS**  
**Symbols**

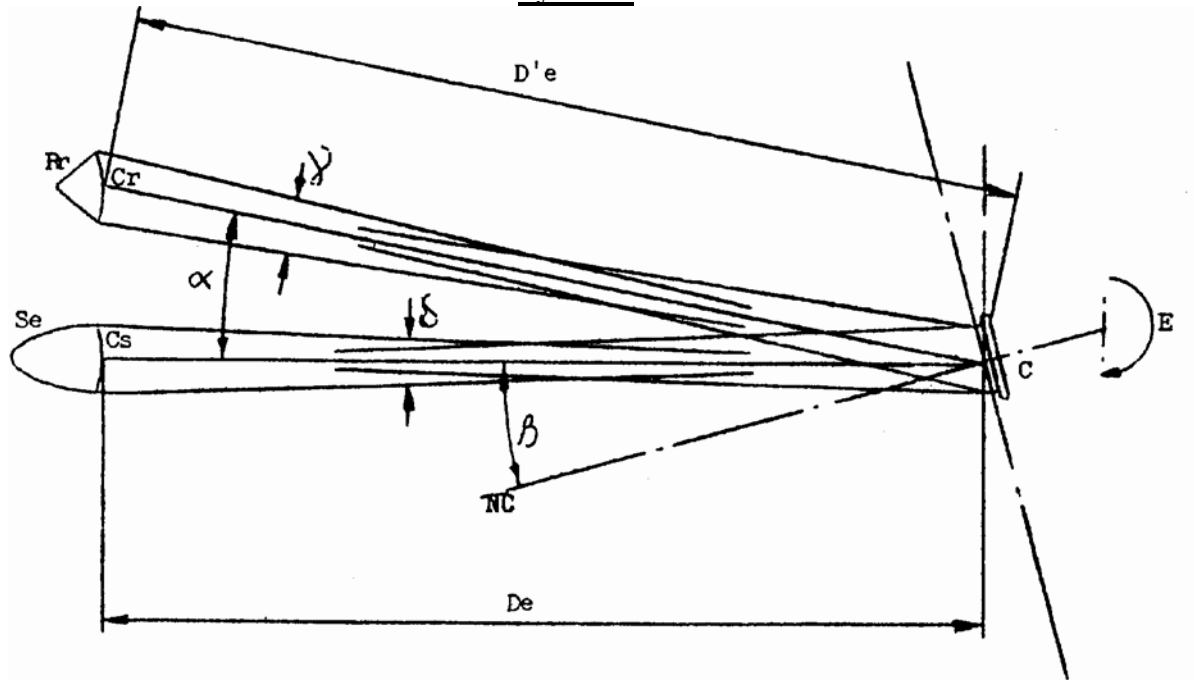

ELEVATION

**Annex 2**  
**COMMUNICATION**

(Maximum format: A.4 (210 x 297mm))

Issued by: Name of administration:

.....  
.....  
.....



Concerning: <sup>2/</sup> APPROVAL  
GRANTED APPROVAL EXTENDED  
APPROVAL REFUSED  
APPROVAL WITHDRAWN  
PRODUCTION DEFINITELY DISCONTINUED

of a type of retro-reflecting device pursuant to Regulation No. 3.

Approval No. .... Extension No. ....

1. Trade name or mark of the device:.....
2. Manufacturer's name for the type of device:.....
3. Manufacturer's name and address:.....
4. If applicable, name and address of the manufacturer's representative:.....
5. Submitted for approval on:.....
6. Technical service responsible for conducting approval tests:.....
7. Date of test report:.....
8. Number of test report:.....
9. Concise description:.....  
In isolation/part of an assembly of devices: <sup>2/</sup> .....
- Colour of light emitted: white/red/amber: <sup>2/</sup> .....
10. Position of the approval mark:.....
11. Reason(s) for extension (if applicable):.....
12. Approval granted/refused/extended/withdrawn: <sup>2/</sup> .....
13. Place:.....
14. Date:.....
15. Signature:.....
16. The following documents, bearing the approval number shown above, are available on request:

<sup>1/</sup>Distinguishing number of the country which has granted/extended/refused/withdrawn approval (see approval provisions in the Regulation).

<sup>2/</sup>Strike out what does not apply.

**Annex 3**

**EXAMPLES OF APPROVAL MARKS**

**Figure 1 (Marking for single lamps)**

**Model A**

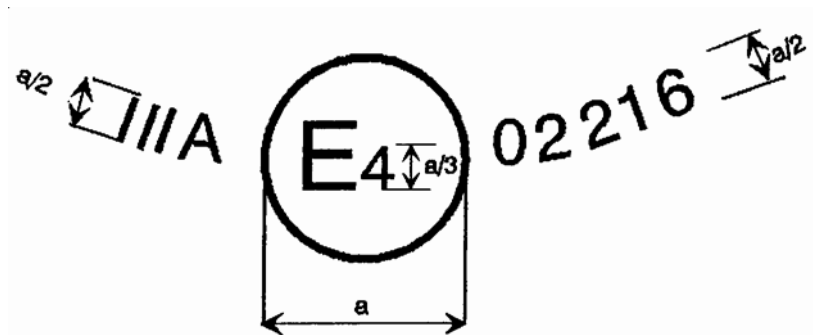

a = 4 mm min.

**Model B**

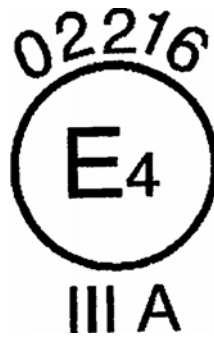

a = 4 mm min.

**Model C**



a = 4 mm min.



Note: The approval number must be placed close to, but in any position in relation to, the circle surrounding the letter "E". The digits constituting the approval number must face the same way as the "E". The group of symbols indicating the class must be diametrically opposite the approval number. The competent authorities shall avoid using approval numbers IA, IB, IIIA and IVA which might be confused with the class symbols IA, IB, IIIA and IVA.

These sketches show various possible arrangements and are given as examples only.

The above approval mark affixed to a retro-reflecting device shows that the type of device concerned has been approved in the Netherlands (E 4) under approval number 02216. The approval number shows that approval was granted in accordance with the requirements of the Regulation as modified by the 02 series of amendments.

Figure 2

(Simplified marking for grouped, combined or reciprocally incorporated lamps)

**Model D**

	3333 ⓔ <sub>4</sub> →			
	IA 02	2 a 00	R 01	
	F 00	AR 00	S2 01	

**MODEL E**

	IA 02 F 00	2 a 00 AR 00	R 01 S2 01	
	3333 ⓔ <sub>4</sub> →			

**MODEL F**

IA 02	2a 00	R 01			
F 00	AR 00	S2 01			
3333 					

Note: The three examples of approval marks, models D, E and F represent three possible variations of the marking of a lighting device when two or more lamps are part of the same unit of grouped, combined or reciprocally incorporated lamps. This approval mark shows that the device was approved in the Netherlands (E 4) under approval number 3333 and comprising:

A retro-reflecting of class I A approved in accordance with the 02 series of amendments to Regulation No. 3; A rear direction indicator of category 2a approved in accordance with Regulation No. 6 in its original form; A red rear position lamp (R) approved in accordance with the 01 series of amendments of Regulation No. 7; A rear fog lamp (F) approved in accordance with Regulation No. 38 in its original form;

A reversing lamp (AR) approved in accordance with Regulation No. 23 in its original form;

A stop lamp with two levels of illumination (S2) approved in accordance with the 01 series of amendments to Regulation No. 7.

## **Annex 4**

### **TEST PROCEDURE - CLASS I A AND CLASS III A**

1. The applicant shall submit for approval ten samples which shall be tested in the chronological order indicated in annex 12.
  2. After verification of the general specifications (paragraph 6 of the Regulation) and the specifications of shape and dimensions (annex 5), the ten samples shall be subjected to the heat resistance test described in annex 10 to this Regulation and at least one hour after this test examined as to their colorimetric characteristics (annex 6) and CIL (annex 7) for an angle of divergence of 20' and an illumination angle  $V = H = 0$  degrees or if necessary, in the position defined in annex 7, paragraphs 4 and 4.1. The two retro-reflecting devices giving the minimum and maximum values shall then be fully tested as shown in annex 7. These two samples shall be kept by the laboratories for any further checks which may be found necessary. The other eight samples shall be divided into four groups of two:  

First Group:

The two samples shall be subjected successively to the water penetration test (Annex 8, paragraph 1.1.) and then, if this test is satisfactory, to the tests for resistance to fuels and lubricants (Annex 8, paragraphs 3 and 4).

Second Group:

The two samples shall, if necessary, be subjected to the corrosion test (annex 8, paragraph 2), and then to the abrasive-strength test of the rear face of the retro-reflecting device (annex 8, paragraph 5).

Third Group:

The two samples shall be subjected to the test for stability in time of the optical properties of retro-reflecting device (annex 9).

Fourth Group:

The two samples shall be subjected to the colour-fastness test (annex 11).
  3. After undergoing the tests referred to in the above paragraph, the retro-reflecting devices in each group must have:
    - 3.1. a colour which satisfies the conditions laid down in annex 6. This shall be verified by a qualitative method and, in case of doubt, confirmed by a quantitative method.
    - 3.2. a CIL which satisfies the conditions laid down in annex 7. The verification shall be performed only for an angle of divergence of 20 and an illumination angle of  $V = H = 0$  degrees or, if necessary, in the position specified in annex 7, paragraphs 4 and 4.1.
-

## **Annex 5**

### **SPECIFICATIONS OF SHAPE AND DIMENSIONS**

#### **1. SHAPE AND DIMENSIONS OF RETRO-REFLECTING DEVICES IN CLASS IA OR IB**

- 1.1. The shape of the illuminating surfaces must be simple, and not easily confused at normal observation distances, with a letter, a digit or a triangle.
- 1.2. The preceding paragraph notwithstanding, a shape resembling the letters or digits of simple form O, I, U or 8 is permissible.

#### **2. SHAPE AND DIMENSIONS OF RETRO-REFLECTING DEVICES IN CLASS III A**

(See appendix to this annex)

- 2.1. The illuminating surfaces of retro-reflecting devices in Class III A must have the shape of an equilateral triangle. If the word "TOP" is inscribed in one corner, the apex of that corner must be directed upwards.
- 2.2. The illuminating surface may or may not have at its centre a triangular, non-retro-reflecting area, with sides parallel to those of the outer triangle.
- 2.3. The illuminating surface may or may not be continuous. In any case, the shortest distance between two adjacent retro-reflecting optical units must not exceed 15mm.
- 2.4. The illuminating surface of a retro-reflecting device shall be considered to be continuous if the edges of the illuminating surfaces of adjacent separate optical units are parallel and if the said optical units are evenly distributed over the whole solid surface of the triangle.
- 2.5. If the illuminated surface is not continuous, the number of separate retro-reflecting optical units including the corner units shall not be less than four on each side of the triangle.
  - 2.5.1. The separate retro-reflecting optical units shall not be replaceable unless they consist of approved retro-reflecting devices in Class I A.
- 2.6. The outside edges of the illuminating surfaces of triangular retro-reflecting devices in Class III A shall be between 150 and 200mm long. In the case of devices of hollow-triangle type, the width of the sides, measured at right angles to the latter, shall be equal to at least 20% of the effective length between the extremities of the illuminating surface.

#### **3. SHAPE AND DIMENSIONS OF RETRO-REFLECTING DEVICES IN CLASS IV A**

- 3.1. The shape of the light emitting surfaces must be simple and not easily confused at normal observation distances with a letter, a digit or a triangle. However, a shape resembling the letters and digits of simple form, O, I, U and 8 is permissible.
- 3.2. The light emitting surface of the retro-reflecting device must be at least 25cm<sup>2</sup>.

- 4. COMPLIANCE WITH THE ABOVE SPECIFICATIONS SHALL BE VERIFIED BY VERIFIED BY VISUAL INSPECTION.**

**Annex 5 - Appendix**  
**RETRO-REFLECTING FOR TRAILERS - CLASS III A**

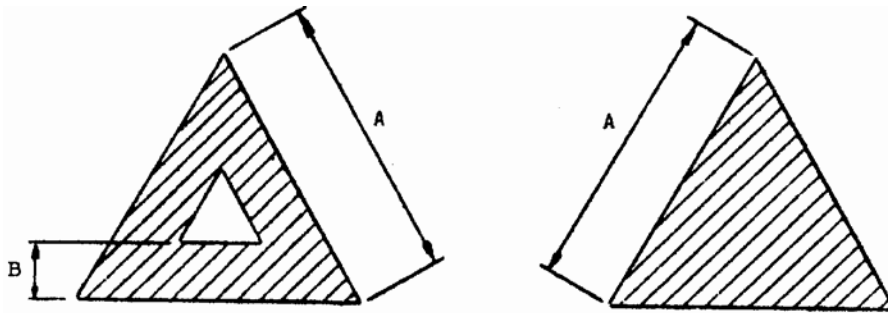

$150 \text{ mm} \leq A \leq 200 \text{ mm}$   
 $B \geq \frac{A}{5}$   
 $C \leq 15 \text{ mm}$

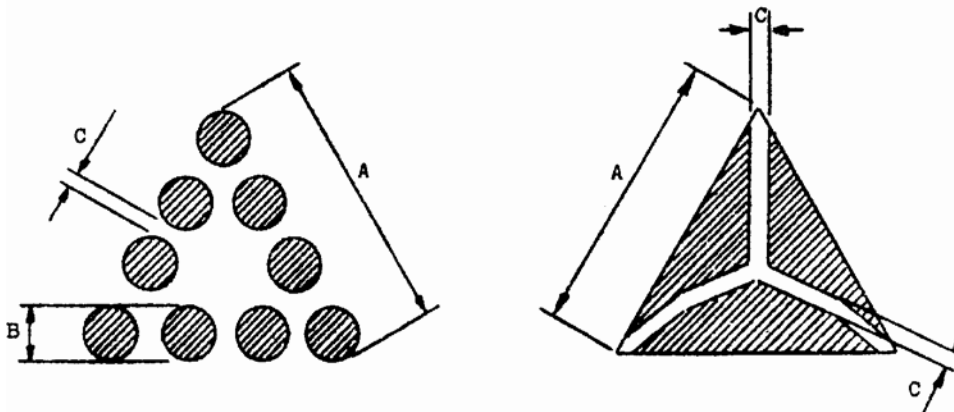

Note: These sketches are for illustration purposes only.

## Annex 6

### COLORIMETRIC SPECIFICATIONS

1. These specifications shall apply only to clear, red or amber retro-reflecting devices.
    - 1.1. Retro-reflecting devices may consist of a combined retro-reflecting optical unit and filter, which must be so designed that they cannot be separated under normal conditions of use.
    - 1.2. The colouring of retro-reflecting optical units and filters by means of paint or varnish is not permitted.
  2. When the retro-reflecting device is illuminated by ICI standard illuminant A, with an angle of divergence of 1/3 degrees and an illumination angle  $V=H=0$  degrees, or, if this produces a colourless surface reflection, an angle  $V= \pm 5$  degrees,  $H=0$  degrees, the trichromatic coordinates of the reflected luminous flux must be within the following limits:

RED:	Limit towards yellow:	$y < 0.335$
	Limit toward purple:	$z < 0.008$
AMBER:	Limit towards yellow	$y < 0.429$
	Limit towards red:	$y < 0.398$
	Limit towards white:	$z > 0.007$
  - 2.1. In the case of red and amber, compliance with the colorimetric specifications shall be verified by a visual comparison test.
  - 2.2. If any doubt remains after this test, compliance with the colorimetric specifications shall be verified by determining the trichromatic co-ordinates of the most doubtful sample.
  3. Clear retro-reflecting devices must not produce a selective reflection, that is to say, the trichromatic co-ordinates "x" and "y" of the standard illuminant "A" used to illuminate the retro-reflecting device must not undergo a change of more than 0.01 after reflection by the retro-reflecting device.
    - 3.1. This shall be verified by the visual comparison test indicated above, the control field being illuminated by a light source of which the trichromatic coordinates differ by 0.01 from that of standard illuminant A.
    - 3.2. In case of doubt, the trichromatic coordinates for the most selective sample shall be determined.
-

**Annex 7**

**PHOTOMETRIC SPECIFICATIONS**

1. When applying for approval, the applicant shall specify the axis of reference. This corresponds to the illumination angle  $V = H = 0$  degrees in the table of coefficients of luminous intensity (CIL).
2. For photometric measurements only the illuminating surface contained within a circle of 200mm diameter for Class IA or IB shall be considered, and the illuminating surface itself shall be limited to 100cm<sup>2</sup> though the surfaces of the retro-reflecting optical units need not necessarily attain this area. The manufacturer shall specify the perimeter of the area to be used. In the case of Class III A and IV A the whole of the illuminating surfaces shall be considered without limitation as to size.
3. **CIL values**
  - 3.1. Class IA, Class IB and Class IIIA
    - 3.1.1. The CIL values for red retro-reflecting devices must be at least equal to those in the table below, expressed in millicandelas per lux, for the angles of divergence and illumination shown.

Class	Class Divergence Alpha	Illumination angles (in degrees)			
		Vertical V Horizontal H	0 degrees 0 degrees	+/- 10 degree 0 degree	+/- 5 degree +/- 20 degrees
I A, I B	20'		300	200	100
	1 degree 30'		5	2.8	2.5
III A	20'		450	200	150
	1 degree 30'		12	8	8

CIL values lower than those shown in the last two columns of the above table are not permissible within the solid angle having the reference centre as its apex and bounded by the planes intersecting along the following lines:

( $V = +/- 10$  degrees,  $H = 0$  degrees)

( $V = +/- 5$  degrees,  $H = +/- 20$  degrees).

- 3.1.2. CIL values for amber retro-reflecting devices in class IA or IB must be at least equal to those in the table of paragraph 3.1.1. above multiplied by the coefficient 2.5;
- 3.1.3. CIL values for colourless retro-reflecting devices in class IA or IB must be at least equal to those in the table of paragraph 3.1.1. above multiplied by the coefficient 4.
- 3.2. For devices of Class IV A the CIL values must be at least equal to those in the table below, expressed in millicandelas per lux, for the angles of divergence and illumination shown.



Colour	Angle of Divergence alpha	Illumination angles (in degrees)						
		Vertical V Horizontal H	0 0	+/- 10 0	0 +/- 20	0 +/- 30	0 +/- 40	0 +/- 50
White	20 degree 1 degree 30'		1,800 34	1,200 24	610 15	540 15	470 15	400 15
Amber	20' 1 degree 30'		1,125 21	750 15	380 10	335 10	290 10	250 10
Red	20' 1 degree 30'		450 9	300 6	150 4	135 4	115 4	100 4

4. When the CIL of a retro-reflecting device is measured for an angle beta of  $V = H = 0$  degrees, it shall be ascertained whether any mirror effect is produced by slightly turning the device. If there is any such effect, a reading shall be taken with an angle beta of  $V = +/- 5$  degrees,  $H = 0$  degrees. The position adopted shall be that corresponding to the minimum CIL for one these positions.
- 4.1. With an illumination angle beta of  $V = H = 0$  degrees, or the angle specified in paragraph 4 above, and an angle of divergence of 20', retro-reflecting devices which are not marked "TOP" shall be rotated about their axes of reference to the position of minimum CIL, which must conform to the value specified in paragraph 3 above. When the CIL is measured for the other angles of illumination and divergence, the retro-reflecting device shall be placed in the position corresponding to this value of e. If the specified values are not attained, the device may be rotated about its axis of reference +/- 5 degrees from that position.
- 4.2. With an illumination angle beta of  $V = H = 0$  degrees, or the angle specified in paragraph 4 above, and an angle of divergence of 20', retro-reflecting devices marked "TOP" shall be rotated about their axes +/- 5 degrees. The CIL must not fall below the prescribed value in any position assumed by the device during this rotation.
- 4.3. If for the direction  $V = H = 0$  degrees, and for  $e = 0$  degrees the CIL exceeds the specified value by 50% or more, all measurements for all angles of illumination and divergence shall be made for  $e = 0$  degrees.

## Annex 8

### RESISTANCE TO EXTERNAL AGENTS

#### 1. Resistance to water and dirt penetration

##### 1.1. Water submersion test

1.1.1. Retro-reflecting devices whether part of a lamp or not, shall be stripped of all removable parts and immersed for 10 minutes in water at a temperature of 50 degrees +/-5 degreesC, the highest point of the upper part of the illuminating surface being 20mm below the surface of the water. This test shall be repeated after turning the retro- reflecting device through 180 degrees, so that the illuminating surface is at the bottom and the rear face is covered by about 20mm of water. These optical units shall then be immediately immersed in the same conditions in water at a temperature of 25 degrees +/- 5 degreesC.

1.1.2. No water shall penetrate to the reflecting surface of the retro-reflecting optical unit. If visual inspection clearly reveals the presence of water, the device shall not be considered to have passed the test.

1.1.3. If visual inspection does not reveal the presence of water or in case of doubt, the CIL shall be measured by the method described in annex 4, paragraph 3.2., or annex 14, paragraph 4.2., the retro-reflecting device being first lightly shaken to remove excess water from the outside.

##### 1.2. Alternative test procedure for Class IB devices

As an alternative, at the request of the manufacturer, the following test (moisture and dust test) shall be applied instead of the submersion-test specified in paragraph 1.1. above.

##### 1.2.1. Moisture test

The test evaluates the ability of the sample device to resist moisture penetration from a water spray and determines the drainage capability of those devices with drain holes or other exposed openings in the device.

##### 1.2.1.1. Water spray test equipment

A water spray cabinet with the following characteristics shall be used:

##### 1.2.1.1.1. Cabinet

The cabinet shall be equipped with a nozzle(s) which provides a solid cone water spray of sufficient angle to completely cover the sample device. The centreline of the nozzle(s) shall be directed downward at an angle of 45 degrees +/- 5 degrees to the vertical axis of a rotating test platform.

##### 1.2.1.1.2. Rotating test platform

The rotating test platform shall have a minimum diameter of 140mm and rotate about a vertical axis in the centre of the cabinet.

##### 1.2.1.1.3. Precipitation rate

The precipitation rate of the water spray at the device shall be 2.5 (+ 1.6/-0) mm/min as measured with a vertical cylindrical collector centred on the

vertical axis of the rotating test platform. The height of the collector shall be 100mm and the inside diameter shall be a minimum of 140mm.

1.2.1.2. Water spray test procedure

A sample device mounted on a test fixture, with initial CIL measured and recorded shall be subjected to a water spray as follows:

1.2.1.2.1. Device openings

All drain holes and other openings shall remain open. Drain wicks, when used, shall be tested in the device.

1.2.1.2.2. Rotational speed

The device shall be rotated about its vertical axis at a rate of 4.0 +/- 0.5min<sup>-1</sup>.

1.2.1.2.3. If the retro-reflector is reciprocally incorporated with signalling or lighting functions, these functions shall be operated at design voltage according to a cycle of 5min ON (in flashing mode, where appropriate), 55min OFF.

1.2.1.2.4. Test duration

The water spray test shall last 12 h (12 cycles of 5/55min).

1.2.1.2.5. Drain period

The rotation and the water spray shall be turned OFF and the device allowed to drain for 1h with the cabinet door closed.

1.2.1.2.6. Sample evaluation

Upon completion of the drain period. The interior of the device shall be observed for moisture accumulation. No standing pool of water shall be allowed to be formed, or which can be formed by tapping or tilting the device. The CIL shall be measured according to the method specified in annex 4 paragraph 3.2. after having dried the exterior of the device with a dry cotton cloth.

1.2.2. Dust exposure test

This test evaluates the ability of the sample device to resist dust penetration which could significantly affect the photometric output of the retro-reflector.

1.2.2.1. Dust exposure test equipment

The following equipment shall be used to test for dust exposure:

1.2.2.1.1. Dust exposure test chamber

The interior of the test chamber shall be cubical in shape in size 0.9 to 1.5m per side. The bottom may be "hopper shaped" to aid in collecting the dust. The internal chamber volume, not including a "hopper shaped" bottom shall be 2m<sup>3</sup> maximum and shall be charged with 3 to 5kg of the test dust. The chamber shall have the capability of agitating the test dust by means of compressed air or blower fans in such a way that the dust is diffused throughout the chamber.

---

1.2.2.1.2. The dust

The test dust used shall be fine powdered cement in accordance with standard ASTM C 150-84.<sup>\*/</sup>

1.2.2.2. Dust exposure test procedure

A sample device, mounted on a test fixture, with the initial CIL measured and recorded, shall be exposed to dust as follows:

1.2.2.2.1. Device openings

All drain holes and other openings shall remain open. Drain wicks, when used, shall be tested in the device.

1.2.2.2.2. Dust exposure

The mounted device shall be placed in the dust chamber no closer than 150mm from a wall. Devices with a length exceeding 600mm shall be horizontally centred in the test chamber. The test dust shall be agitated as completely as possible by compressed air or blower(s) at intervals of 15min for a period of 2 to 15s for the duration of 5 hours. The dust shall be allowed to settle between the agitation periods.

1.2.2.2.3. Measured sample evaluation

Upon completion of the dust exposure test, the exterior of the device shall be cleaned and dried with a dry cotton cloth and the CIL measured according to the method specified in annex 4, paragraph 3.2.

**2. RESISTANCE TO CORROSION**

2.1. Retro-reflecting devices must be so designed that they retain the prescribed photometric and colorimetric characteristics despite the humidity and corrosive influences to which they are normally exposed. The resistance of the front surface to tarnishing and of the protection of the rear face to deterioration shall be checked, particularly when an essential metal component seems liable to be attacked.

2.2. The retro-reflecting device, or the lamp if the device is combined with a light, shall be stripped of all removable parts and subjected to the action of a saline mist for a period of 50 hours, comprising two periods of exposure of 24 hours each, separated by an interval of two hours during which the sample is allowed to dry.

2.3. The saline mist shall be produced by atomizing, at a temperature of 35 degrees +/- 2 degrees C, a saline solution obtained by dissolving 20 +/- 2 parts by weight of sodium chloride in 80 parts of distilled water containing not more than 0.02% of impurities.

2.4. Immediately after completion of the test, the sample must not show signs of excessive corrosion liable to impair the efficiency of the device.

**3. RESISTANCE TO FUELS**

The outer surface of the retro-reflecting device and, in particular, of the illuminating surface, shall be lightly wiped with a cotton cloth soaked in a

---

<sup>\*/</sup> American society for Testing and Materials

mixture of 70 vol. % of n- heptane and 30 vol. % of toluol. After about five minutes, the surface shall be inspected visually. It must not show any apparent surface changes, except that slight surface cracks will not be objected to.

**4. RESISTANCE TO LUBRICATING OILS**

The outer surface of the retro-reflecting device and, in particular, the illuminating surface, shall be lightly wiped with a cotton cloth soaked in a detergent lubricating oil. After about 5 minutes, the surface shall be cleaned. The CIL shall then measured (annex 4, paragraph 3.2. or annex 14, paragraph 4.2.).

**5. RESISTANCE OF THE ACCESSIBLE REAR FACE OF MIRROR-BACKED RETRO-REFLECTING DEVICES**

- 5.1. After having brushed the rear face of the retro-reflecting device with a hard nylon brush, a cotton cloth soaked in the mixture, defined in paragraph 3 shall be applied to the said rear face for one minute. The cotton cloth is then removed and the retro-reflecting device left to dry.
- 5.2. As soon as evaporation is completed, an abrasion test shall be made by brushing the rear face with the same nylon brush as before.
- 5.3. The CIL shall then be measured (annex 4, paragraph 3.2. or annex 14, paragraph 4.2.), after the whole surface of the mirror-backed rear face has been covered with Indian ink.

## **Annex 9**

### **STABILITY IN TIME OF THE OPTICAL PROPERTIES <sup>1/</sup> OF RETRO-REFLECTING DEVICES**

1. The authority which granted approval shall have the right to check the stability in time of the optical properties of a type of retro-reflecting device in service.
2. The competent authorities of countries other than the country in which approval was granted may carry out similar checks in their territory. If a type of retroreflector in use exhibits a systematic defect, the said authorities shall transmit any components removed for examination to the authority which granted approval, with a request for its opinion.
3. In the absence of other criteria, the concept of "systematic defect" of a type of retroreflector in use shall be interpreted in conformity with the intention of paragraph 6.1. of this Regulation.

---

<sup>1/</sup> Despite the importance of tests to check the stability in time of the optical properties of retro-reflecting devices, it is in the present state of the art not yet possible to assess this stability by laboratory tests of limited duration.

---

### **Annex 10**

#### **RESISTANCE TO HEAT**

1. The retro-reflecting device shall be kept for 48 consecutive hours in a dry atmosphere at a temperature of 65 +/- 2 degrees C.
2. After this test, no cracking or appreciable distortion of the retro-reflecting device and, in particular, of its optical component must be visible.

## **Annex 11**

### **COLOUR-FASTNESS <sup>1/</sup>**

1. The authority which granted approval shall have the right to check the colour-fastness of a type of retro-reflecting device in service.
2. The competent authorities of countries other than country in which approval was granted may carry out similar checks in their territory. If a type of retroreflector in use exhibits a systematic defect, the said authorities shall transmit any components removed for examination to the authority which granted approval, with a request for its opinion.
3. In the absence of other criteria, the concept "systematic defect" of a type of retroreflector in use shall be interpreted in conformity with the intention of paragraph 9.1. of this Regulation.

---

<sup>1/</sup> Despite the importance of tests to check the colour-fastness of retro-reflecting devices, it is in the present state of the art not yet possible to assess colour-fastness by laboratory tests of limited duration.

---



**Annex 12**  
**CHRONOLOGICAL ORDER OF TESTS**

Number of annex	Number of Paragraph	TEST	SAMPLES											
			a	b	c	d	e	f	g	h	i	j		
-	6. <sup>*/</sup>	General specifications: visual inspection	x	x	x	x	x	x	x	x	x	x	x	x
5		Shapes and dimensions: visual inspection	x	x	x	x	x	x	x	x	x	x	x	x
10		Heat: 48 h at 65 degrees +/- 2 degreesC Visual inspection for distortion	x	x	x	x	x	x	x	x	x	x	x	x
6		Colorimetry: visual inspection Trichromatic coordinates in case of doubt	x	x	x	x	x	x	x	x	x	x	x	x
7 7	3.	Photometry: limited to 20' and V = H = 0 degrees Complete photometry	x	x	x	x	x	x	x	x	x	x	x	x
8	1.	Water: 10min. in normal position 10min. in inverted position visual inspection								x	x			
4	3.1.	Colorimetry: visual inspection Trichromatic coordinates in case of doubt								x	x			
4	3.2.	Photometry: limited to 20' and V = H = 0 degrees								x	x			
8	3.	Motor fuels: 5 min. visual inspection								x	x			
8	4.	Oils: 5 min. visual inspection								x	x			
4	3.1.	Colorimetry: visual inspection Trichromatic coordinates in case of doubt								x	x			
4	3.2.	Photometry: limited to 20' and V = H = 0 degrees								x	x			
8	2.	Corrosion: 24 hours 2 hours interval 24 hours visual inspection						x	x					
8	5.	Rear face: 1 min. visual inspection						x	x					
4	3.1.	Colorimetry: visual inspection Trichromatic coordinates in case of doubt						x	x					
4	3.2.	Photometry: limited to 20' and V = H = 0 degrees						x	x					
9		Stability in time												
4	3.1.	Colorimetry: visual inspection or Trichromatic coordinates												
4	3.2.	Photometry: limited to 20' and V = H = 0 degrees												
11		Colour-fastness												

Number of	Number of	TEST	SAMPLES										
4	3.1.	Colorimetry: visual inspection or Trichromatic coordinates											
4	3.2.	Photometry: limited to 20' and V = H = 0 degrees											
4	2.	Deposit of samples with administration		x	x								

\*/ Of the Regulation.

### Annex 13

#### RESISTANCE TO IMPACT - CLASS IV A

1. The retro-reflecting device shall be mounted in a manner similar to the way in which it is mounted on the vehicle, but with the lens faced horizontal and directed upwards.
2. Drop a 13mm diameter polished solid steel ball, once, vertically onto the central part of the lens from a height of 0.76m. The ball may be guided but not restricted in free fall.
3. When a retro-reflecting device is tested at room temperature with this method, the lens shall not crack.

## **Annex 14**

### **TEST PROCEDURE - CLASS IV A**

1. The applicant shall submit for approval ten samples which shall be tested in the chronological order indicated in annex 15.
  2. After verification of the specifications in paragraphs 6.1. to 6.5. and the specifications of shape and dimensions (annex 5), the ten samples shall be subjected to the heat resistance test (annex 10) and one hour minimum after this test examined as to their colorimetric characteristics (annex 6) and CIL (annex 7) for an angle of divergence of 20' and an illumination angle  $V = H = 0$  degrees or, if necessary, in the positions defined in annex 7. The two retro-reflecting devices giving the minimum and maximum values shall then be fully tested as shown in annex 7. These two samples shall be kept by the laboratories for any further checks which may be found necessary.
  3. Four samples out of the remaining eight samples shall be selected at random and divided into two groups of two in each group.  

First group:

The two samples shall be subjected successively to the water-penetration resistance test (annex 8, paragraph 1) and then, if this test is satisfactory, to the tests for resistance to fuels and lubricating oils (annex 8, paragraphs 3 and 4).

Second group:

The two samples shall, if relevant, be subjected to the corrosion test (annex 8, paragraph 2), and then to the abrasive-strength test of the rear face of the retro-reflecting device (annex 8, paragraph 5). These two samples shall also be subjected to the impact test (annex 13).
  4. After undergoing the tests referred to in the above paragraph, the retro-reflecting devices in each group must have:
    - 4.1. A colour which satisfies the conditions laid down in annex 6. This shall be verified by a qualitative method and, in case of doubt, confirmed by a quantitative method;
    - 4.2. A CIL which satisfies the conditions laid down in annex 7. Verification shall be performed only for an angle of divergence of 20' and an illumination angle of  $V = H = 0$  degrees or, if necessary, in the positions specified in annex 7.
  5. The four remaining samples can be utilized, if necessary, for any other purpose.
-

**Annex 15**  
**CHRONOLOGICAL ORDER OF TESTS FOR CLASS IV A**

Number of annex	Number of Paragraph	TEST	SAMPLES												
			a	b	c	d	e	f	g	h	i	j			
-	6. <sup>*/</sup>	General specifications: visual inspection	x	x	x	x	x	x	x	x	x	x	x	x	x
5		Shapes and dimensions: visual inspection	x	x	x	x	x	x	x	x	x	x	x	x	x
10	-	Heat: 48 h at 65 degrees +/- 2 degreesC Visual inspection for distortion	x	x	x	x	x	x	x	x	x	x	x	x	x
6	-	Colorimetry: visual inspection Trichromatic coordinates in case of doubt	x	x	x	x	x	x	x	x	x	x	x	x	x
7	-	Photometry: limited to 20' and V = H = 0 degrees	x	x	x	x	x	x	x	x	x	x	x	x	x
7	-	Complete photometry	x	x											
8	1.	Water: 10min. in normal position 10min. in inverted position visual inspection			x	x									
8	3.	Motor fuels: 5min. visual inspection			x	x									
8	4.	Oils: 5min. visual inspection			x	x									
6	-	Colorimetry: visual inspection Trichromatic coordinates in case of doubt			x	x									
7	-	Photometry: limited to 20' and V = H = 0 degrees			x	x									
8	2.	Corrosion: 24 hours 2 hours interval 24 hours visual inspection						x	x						
8	5.	Rear face: 1min. visual inspection						x	x						
13		Impact visual inspection						x	x						
6	-	Colorimetry: visual inspection Trichromatic coordinates in case of doubt						x	x						
7	-	Photometry: limited to 20' and V = H = 0 degrees						x	x						
14	2.	Deposit of samples with administration	x	x											

<sup>\*/</sup> of the Regulation

## **Annex 16**

### **TEST PROCEDURE FOR CLASS IB DEVICES**

Retro-reflecting devices of Class IB shall be tested according to the test procedures specified in Annex 4, following the chronological order of tests given in annex 12, with the exception of the test according to annex 8, paragraph 1, which for Class IB devices may be replaced by the test specified in annex 8, paragraph 1.2.

## Annex 17

### MINIMUM REQUIREMENTS FOR CONFORMITY OF PRODUCTION CONTROL PROCEDURES

#### 1. GENERAL

- 1.1. The conformity requirements shall be considered satisfied from a mechanical and geometric standpoint, if the differences do not exceed inevitable manufacturing deviations within the requirements of this Regulation.
- 1.2. With respect to photometric performances, the conformity of mass-produced retro- reflectors shall not be contested if, when testing photometric performances of any retro- reflector chosen at random no measured value deviates unfavourably by more than 20% from the minimum values prescribed in this Regulation.
- 1.3. The chromaticity coordinates shall be complied with.

#### 2. MINIMUM REQUIREMENTS FOR VERIFICATION OF CONFORMITY BY THE MANUFACTURER

For each type of retro-reflector the holder of the approval mark shall carry out at least the following tests, at appropriate intervals. The tests shall be carried out in accordance with the provisions of this Regulation.

If any sampling shows non-conformity with regard to the type of test concerned, further samples shall be taken and tested. The manufacturer shall take steps to ensure the conformity of the production concerned.

##### 2.1. Nature of tests

Tests of conformity in this Regulation shall cover the photometric and colorimetric characteristics and the resistance to penetration of water.

##### 2.2. Methods used in tests

- 2.2.1. Tests shall generally be carried out in accordance with the methods set out in this Regulation.
- 2.2.2. In any test of conformity carried out by the manufacturer, equivalent methods may be used with the consent of the competent authority responsible for approval tests. The manufacturer is responsible for proving that the applied methods are equivalent to those laid down in this Regulation.
- 2.2.3. The application of paragraphs 2.2.1. and 2.2.2. requires regular calibration of test apparatus and its correlation with measurements made by a competent authority.
- 2.2.4. In all cases the reference methods shall be those of this Regulation, particularly for the purpose of administrative verification and sampling.

##### 2.3. Nature of sampling

Samples of retro-reflectors shall be selected at random from the production of a uniform batch. A uniform batch means a set of retro-reflectors of the

same type, defined according to the production methods of the manufacturer.

The assessment shall in general cover series production from individual factories.

However, a manufacturer may group together records concerning the same type from several factories, provided these operate under the same quality system and quality management.

2.4. Measured and recorded photometric characteristics

The sampled retro-reflector shall be subjected to photometric measurements at the points and the chromaticity coordinates provided for in the Regulation.

2.5. Criteria governing acceptability

The manufacturer is responsible for carrying out a statistical study of the test results and for defining, in agreement with the competent authority, criteria governing the acceptability of his products in order to meet the specifications laid down for the verification of conformity of products in paragraph 8.1. of this Regulation.

The criteria governing the acceptability shall be such that, with a confidence level of 95%, the minimum probability of passing a spot check in accordance with annex 18 (first sampling) would be 0.95.



## Annex 18

### MINIMUM REQUIREMENTS FOR SAMPLING BY AN INSPECTOR

#### 1. GENERAL

- 1.1. The conformity requirements shall be considered satisfied from a mechanical and a geometric standpoint, in accordance with the requirements of this Regulation, if any, if the differences do not exceed inevitable manufacturing deviations.
- 1.2. With respect to photometric performance, the conformity of mass-produced retro-reflectors shall not be contested if, when testing photometric performances of any retro- reflector chosen at random:
- 1.2.1. no measured value deviates unfavourably by more than 20% from the minimum values prescribed in this Regulation.
- 1.2.2. Retro-reflectors with apparent defects are disregarded.
- 1.3. The chromaticity coordinates shall be complied with.

#### 2. FIRST SAMPLING

In the first sampling four retro-reflectors are selected at random. The first sample of two is marked A, the second sample of two is marked B.

- 2.1. The conformity is not contested
- 2.1.1. Following the sampling procedure shown in Figure 1 of this annex the conformity of mass-produced retro-reflectors shall not be contested if the deviation of the measured values of the retro-reflectors in the unfavourable directions are:
- 2.1.1.1. sample A
- |     |   |     |
|-----|---|-----|
| A1: | one retro-reflector.....                | 0%  |
|     | one retro-reflector not more than ..... | 20% |
| A2: | both retro-reflectors more than .....   | 0%  |
|     | but not more than .....                 | 20% |
- go to sample B
- 2.1.1.2. sample B
- |     |                            |     |
|-----|----------------------------|-----|
| B1: | both retro-reflectors..... | 0 % |
|-----|----------------------------|-----|
- 2.2. The conformity is contested
- 2.2.1. Following the sampling procedure shown in Figure 1 of this annex the conformity of mass-produced retro-reflectors shall be contested and the manufacturer requested to make his production meet the requirements (alignment) if the deviations of the measured values of the retro-reflectors are:
- 2.2.1.1. sample A
- |     |   |     |
|-----|---|-----|
| A3: | one retro-reflector not more than ..... | 20% |
|     | one retro-reflector more than .....     | 20% |

---

	but not more than .....	30%
2.2.1.2.	sample B	
	B2: in the case of A2	
	one retro-reflector more than.....	0%
	but not more than.....	20%
	one retro-reflector not more than.....	20%
	B3: in the case of A2	
	one retro-reflector.....	0%
	one retro-reflector more than .....	20%
	but not more than .....	30%

2.3. Approval withdrawn

Conformity shall be contested and paragraph 9 applied if, following the sampling procedure in Figure 1 of this annex, the deviations of the measured values of the retro- reflectors are:

2.3.1.	sample A	
	A4: one retro-reflector not more than.....	20%
	one retro-reflector more than .....	30%
	A5: both retro-reflectors more than.....	20%
2.3.2.	sample B	
	B4: in the case of A2	
	one retro-reflector more than.....	0%
	but not more than.....	20%
	one retro-reflector more than .....	20%
	B5:in the case of A2	
	both retro-reflectors more than .....	20%
	B6: in the case of A2	
	one retro-reflector .....	0%
	one retro-reflector more than .....	30 %

**3. REPEATED SAMPLING**

In the cases of A3, B2, B3 a repeated sampling, third sample C of two retro-reflectors and fourth sample D of two retro-reflectors, selected from stock manufactured after alignment, is necessary within two months' time after the notification.

- 3.1. The conformity is not contested
- 3.1.1. Following the sampling procedure shown in Figure 1 of this annex the conformity of mass-produced retro-reflectors shall not be contested if the deviations of the measured values of the retro-reflectors are:

- 3.1.1.1. sample C
- C1: one retro-reflector.....0%
  - one retro-reflector not more than .....20%
  - C2: both retro-reflectors more than.....0%
  - but not more than..... 20%

go to sample D

- 3.1.1.2. sample D
- D1: in the case of C2
  - both retro-reflectors.....0%

3.2. The conformity is contested

3.2.1. Following the sampling procedure shown in Figure 1 of this annex the conformity of mass-produced retro-reflectors shall be contested and the manufacturer requested to make his production meet the requirements (alignment) if the deviations of the measured values of the retro-reflectors are:

- 3.2.1.1. sample D
- D2: in the case of C2
  - one retro-reflector more than..... 0%
  - but not more than.....20%
  - one retro-reflector not more than.....20%

3.3. Approval withdrawn

Conformity shall be contested and paragraph 9 applied if, following the sampling procedure in Figure 1 of this annex, the deviations of the measured values of the retro- reflectors are:

- 3.3.1. sample C
- C3: one retro-reflector not more than.....20%
  - one retro-reflector more than.....20%
  - C4: both retro-reflectors more than.....20%

- 3.3.2. sample D
- D3: in the case of C2
  - one retro-reflector 0 or more than.....0%
  - one retro-reflector more than .....20%

**4. RESISTANCE TO PENETRATION OF WATER**

With respect to the verification of the resistance to penetration of water, the following procedure shall be applied:

One of the retro-reflectors of sample A, after sampling procedure in Figure 1 of this annex, shall be tested according to the procedure described in

paragraph 1 of annex 8 respectively paragraph 3 of annex 14 for class IV A reflectors.

The retro-reflectors shall be considered as acceptable if the test has been passed. However, if the test on sample A is not complied with, the two retro-reflectors of sample B shall be subjected to the same procedure and both shall pass the test.

FIGURE 1

