



Vehicle Standard (Australian Design Rule 50/00 – Front Fog Lamps) 2006

I, JAMES ERIC LLOYD, Minister for Local Government, Territories and Roads,
determine this vehicle standard under subsection 7 (1) of the *Motor Vehicle Standards
Act 1989*.

Dated 5 July 2006

[Signed]

James Eric Lloyd

Minister for Local Government, Territories and Roads

CONTENTS

0.	LEGISLATIVE PROVISIONS.....	3
1.	SCOPE.....	3
2.	APPLICABILITY AND IMPLEMENTATION.....	3
3.	DEFINITIONS	3
4.	REQUIREMENTS	3
5.	EXEMPTIONS AND ALTERNATIVE PROCEDURES	3
6.	SUPPLEMENTARY GENERAL REQUIREMENTS	4
7.	ALTERNATIVE STANDARDS	4
8.	NOTES	4
	APPENDIX A	5

0. LEGISLATIVE PROVISIONS**0.1. NAME OF STANDARD**

0.1.1. This Standard is the Vehicle Standard (Australian Design Rule 50/00 – Front Fog Lamps) 2006.

0.1.2. This Standard may also be cited as Australian Design Rule 50/00 — Front Fog Lamps.

0.2. COMMENCEMENT

0.2.1. This Standard commences on the day after it is registered.

0.3. REPEAL

0.3.1. This Standard repeals each vehicle standard with the name Australian Design Rule 50/00 — Front Fog Lamps that is:

(a) made under section 7 of the Motor Vehicle Standards Act 1989; and

(b) in force at the commencement of this Standard.

0.3.2. This Standard also repeals each instrument made under section 7 of the Motor Vehicle Standards Act 1989 that creates a vehicle standard with the name Australian Design Rule 50/00 — Front Fog Lamps, if there are no other vehicle standards created by that instrument, or amendments to vehicle standards made by that instrument, that are still in force at the commencement of this Standard.

1. SCOPE

This Australian Design Rule (ADR) prescribes the photometric requirements for front fog lamps.

2. APPLICABILITY AND IMPLEMENTATION

2.1. The circumstances under which front fog lamps are mandatory, optional, or prohibited are set out in either ADRs 13/.., 19/.. or 67/..

3. DEFINITIONS

3.1. Refer to paragraph 1 of Appendix A.

4. REQUIREMENTS

4.1. Devices complying with the technical requirements of Appendix A as varied by part 5 Exemptions and Alternative Procedures and part 6 Supplementary General Requirements shall be accepted as complying with this rule.

5. EXEMPTIONS AND ALTERNATIVE PROCEDURES

5.1. The following provisions of Appendix A do not apply. to this rule

5.1.1. Scope (including footnote 1)

Section 2 Application for approval

Section 3	Markings
Section 4	Approval
Section 8	Determination of discomfort (dazzle)
Section 10	Modification of the type of the front fog lamp and extension of approval
Section 11	Conformity of production – partial (for particular deletions to the section refer to paragraph 5.1.2)
Section 12	Penalties for non conformity of production
Section 13	Production definitely discontinued
Section 14	Names and addresses of technical services responsible for conducting approval tests, and of administrative departments
Annexes	
Annex 1	Communication concerning the approval (or refusal or withdrawal of approval or production definitely discontinued) of a type of motor vehicle fog lamp pursuant to Regulation No. 19
Annex 2	Examples of arrangements of approval marks

5.1.2. Paragraphs 2.3 and 3.3 in Annex 7.

6. SUPPLEMENTARY GENERAL REQUIREMENTS

The following general requirements are supplementary to the requirements of Appendix A:

6.1. The requirements and procedures set out in Annexes 6 and 7 of Appendix A are acceptable for the purposes of demonstrating compliance with the technical requirements of this rule.

7. ALTERNATIVE STANDARDS

7.1. The technical requirements of any of the editions of United Nations – Economic Commission for Europe (UN ECE) Regulation No. 19 - UNIFORM PROVISIONS CONCERNING THE APPROVAL OF MOTOR VEHICLE FRONT FOG LAMPS, from the edition incorporating the 01 series of amendments up to and including the edition incorporating the 02 series of amendments are deemed to be equivalent to the technical requirements of the rule.

8. NOTES

8.1. In place of Regulation No 48 where referenced in Appendix A, read ADR 13/00.

8.2. In place of Regulation No 37 where referenced in Appendix A, read ADR 51/00.

APPENDIX A

UN-ECE REGULATION NO. 19/02 UNIFORM PROVISIONS CONCERNING THE APPROVAL OF MOTOR VEHICLE FRONT FOG LAMPS

NOTE:

In view of recent changes to the Regulation, text containing Supplements 8 and 9 have not been incorporated in the main Regulation document. Supplements 8 and 9 have been placed between pages 50 to 53. Changes in the texts of Supplements 8 and 9 will be incorporated into the Regulation when the consolidated document is available from the UN-ECE.

Regulation No. 19
UNIFORM PROVISIONS CONCERNING THE APPROVAL OF
MOTOR VEHICLE FRONT FOG LAMPS

Contents

REGULATION

- Scope
- 1. Definitions
- 2. Application for approval
- 3. Markings
- 4. Approval
- 5. General specifications
- 6. Illumination
- 7. Colour
- 8. Determination of discomfort (dazzle)
- 9. Observation concerning colour
- 10. Modifications of the type of front fog lamp and extension of approval
- 11. Conformity of production
- 12. Penalties for non-conformity of production
- 13. Production definitely discontinued
- 14. Names and addresses of technical services responsible for conducting approval tests, and of administrative departments
- 15. Transitional provisions

ANNEXES

- Annex 1 - Communication concerning the approval or extension or refusal or withdrawal of approval or production definitely discontinued of a type of motor vehicle front fog lamp pursuant to Regulation No. 19 Annex 2- Examples of arrangements of approval marks
- Annex 3- Measuring screen
- Annex 4- Tests for stability of photometric performance of headlamps in operation
- Annex 5- Requirements for lamps incorporating lenses of plastic material - testing of lens or material samples and of complete lamps
- Annex 6- Minimum requirements for conformity of production control procedures
- Annex 7- Minimum requirements for sampling by an inspector

Regulation No. 19

UNIFORM PROVISIONS CONCERNING THE APPROVAL OF MOTOR VEHICLE FRONT FOG LAMPS

SCOPE: ^{1/}

This Regulation applies to front fog lamps which may incorporate lenses of glass or plastic material.

1. DEFINITIONS

For the purpose of this Regulation,

- 1.1. "Front fog lamp" means the lamp on a vehicle which improves the illumination of the road in conditions of fog, snowfall, heavy rain or dust clouds;
- 1.2. "Lens" means the outermost component of the front fog lamp (unit) which transmits light through the illuminating surface;
- 1.3. "Coating" means any product or products applied in one or more layers to the outer face of a lens;
- 1.4. "Front fog lamps of different types" are front fog lamps which differ in such essential respects as:
 - 1.4.1. the trade name or mark;
 - 1.4.2. the characteristics of the optical system;
 - 1.4.3. the inclusion of components capable of altering the optical effects by reflection, refraction, absorption and/or deformation during operation;
 - 1.4.4. the category of filament lamp;
 - 1.4.5. the materials constituting the lenses and coating, if any.

2. APPLICATION FOR APPROVAL

- 2.1. The application for approval shall be submitted by the holder of the trade name or mark or by his duly accredited representative.
- 2.2. The application relating to each type of front fog lamp shall be accompanied by:
 - 2.2.1. a brief technical specification. If the device is not of the sealed-beam type, the category of filament lamp(s) shall be specified; it shall be H₁, H₂, H₃, H₄, H₇, H₈, HB₃, HB₄, H27W/1, H27W/2 or H₁₀ filament lamp(s) as specified in Regulation No. 37;
 - 2.2.2. drawings in triplicate in sufficient detail to permit identification of the type and representing a frontal view of the front fog lamp, with details of lens ribbing if any, and the cross-section; the drawings shall indicate the space reserved for the approval mark;
 - 2.2.3. two samples of the type of front fog lamp;

^{1/} Nothing in this Regulation shall prevent a Party to the Agreement applying this Regulation from prohibiting the combination of a front fog lamp incorporating a plastic lens, approved under this Regulation, with a mechanical headlamp-cleaning device (with wipers).

- 2.2.4. for the test of plastic material of which the lenses are made:
 - 2.2.4.1. thirteen lenses;
 - 2.2.4.1.1. six of these lenses may be replaced by six samples of material at least 60 x 80 mm size, having a flat or convex outer surface and a substantially flat area (radius of curvature not less than 300 mm) in the middle measuring at least 15 x 15 mm);
 - 2.2.4.1.2. every such lens or sample of material shall be produced by the method to be used in mass production;
 - 2.2.4.2. a reflector to which the lenses can be fitted in accordance with the manufacturer's instructions.
- 2.3. The characteristics of the materials making up the lenses and coatings, if any, should be accompanied by the test report on these materials and coatings if they have already been tested.
- 2.4. The competent authority shall verify the existence of satisfactory arrangements for ensuring effective control of the conformity of production before type approval is granted.

3. MARKINGS

- 3.1. The samples of a type of front fog lamp which are submitted for approval shall bear the trade name or mark of the applicant, which shall be clearly legible and be indelible.
- 3.2. They shall comprise, on the lens and on the main body^{2/}, spaces of sufficient size for the approval mark and the additional symbols referred to in paragraph 4; these spaces shall be indicated on the drawings referred to in paragraph 2.2.2. above.

4. APPROVAL

4.1. General

- 4.1.1. If all the samples of a type of front fog lamp submitted in pursuance of paragraph 2. above satisfy the provisions of this Regulation, approval shall be granted.
- 4.1.2. Where grouped, combined or reciprocally incorporated lamps have been found to comply with the requirements of several Regulations, a single international approval mark may be applied provided that each of the grouped, combined or reciprocally incorporated lamps satisfies the provisions applicable to it.
- 4.1.3. An approval number shall be assigned to each type approved. Its first two digits (at present 02) shall indicate the series of amendments incorporating the most recent major technical amendments made to the Regulation at the time of issue of the approval. The same Contracting Party may not assign the same number to another type of front fog lamp covered by this Regulation except in the case of an extension of the approval to a device differing only in the colour of the light emitted.

^{2/} If the lens cannot be detached from the main body of the front fog lamp, a space on the lens shall be sufficient.

- 4.1.4. Notice of approval or of extension or refusal or withdrawal of approval or production definitely discontinued of a type of front fog lamp pursuant to this Regulation shall be communicated to the Parties to the Agreement applying this Regulation by means of a form conforming to the model in annex 1 to this Regulation.
- 4.1.5. In addition to the mark prescribed in paragraph 3.1., an approval mark as described in paragraphs 4.2. and 4.3. below shall be affixed in the spaces referred to in paragraph 3.2. above to every fog lamp conforming to a type approved under this Regulation.
- 4.2. Composition of the approval mark
- The approval mark shall consist of:
- 4.2.1. An international approval marking, comprising:
- 4.2.1.1. a circle surrounding the letter "E" followed by the distinguishing number of the country which has granted approval;^{3/}
- 4.2.1.2. the approval number prescribed in paragraph 4.1.3. above.
- 4.2.2. The following additional symbol (or symbols):
- 4.2.2.1. On front fog lamps meeting the requirements of this Regulation, the letter "B";
- 4.2.2.2. On front fog lamps incorporating a lens of plastic material the group of letters "PL" to be affixed near the symbols prescribed in paragraph 4.2.2.1. above;
- 4.2.2.3. In every case the relevant operating mode used during the test procedure according to paragraph 1.1.1.1. of annex 4 and the permitted voltages according to paragraph 1.1.1.2. of annex 4 shall be stipulated on the approval forms and on the communication forms transmitted to the countries which are Contracting Parties to the Agreement and which apply this Regulation.

In the corresponding cases the device shall be marked as follows:

On units meeting the requirements of this Regulation which are so designed that the filament(s) of one function shall not be lit simultaneously with that of any function with which it may be reciprocally incorporated, an oblique stroke(/) shall be placed behind the symbol in the approval mark of such function.

^{3/} 1 for Germany, 2 for France, 3 for Italy, 4 for the Netherlands, 5 for Sweden, 6 for Belgium, 7 for Hungary, 8 for the Czech Republic, 9 for Spain, 10 for Yugoslavia, 11 for the United Kingdom, 12 for Austria, 13 for Luxembourg, 14 for Switzerland, 15 (vacant), 16 for Norway, 17 for Finland, 18 for Denmark, 19 for Romania, 20 for Poland, 21 for Portugal, 22 for the Russian Federation, 23 for Greece, 24 (vacant), 25 for Croatia, 26 for Slovenia, 27 for Slovakia, 28 for Belarus and 29 for Estonia, 30 (vacant), 31 for Bosnia and Herzegovina, 32-36 (vacant), 37 for Turkey, 38-39 (vacant) and 40 for The former Yugoslav Republic of Macedonia. Subsequent numbers will be assigned to other countries in the chronological order in which they ratify or accede to the Agreement concerning the Adoption of Uniform Technical Prescriptions for Wheeled Vehicles, Equipment and Parts which can be Fitted and /or be Used on Wheeled Vehicles and the Conditions for Reciprocal Recognition of Approvals Granted on the Basis of these Prescriptions, and the numbers thus assigned shall be communicated to the Contracting Parties to the Agreement by the Secretary-General of the United Nations.

However, if only the front fog lamp and the passing lamp shall not be lit simultaneously, the oblique stroke shall be placed behind the fog lamp symbol, this symbol being placed either separately or at the end of a combination of symbols.

On units meeting the requirements of annex 4 to this Regulation only when supplied with a voltage of 6 V or 12 V, a symbol consisting of the number 24 crossed out by an oblique cross (?) shall be placed near the filament lamp holder. The reciprocal lamp incorporation of passing beam lamp and front fog lamp is possible if it is in compliance with Regulation No. 48;

4.2.2.4. The two digits of the approval number (at present 02) which indicate the series of amendments incorporating the most recent major technical amendments made to the Regulation at the time of issue of the approval may be marked close to the above additional symbols;

4.2.2.5. The marks and symbols referred to in paragraphs 4.2.1. and 4.2.2. above shall be clearly legible and be indelible even when the front fog lamp is fitted in the vehicle.

4.3. Arrangement of the approval mark

4.3.1. Independent lamps

Annex 2, figures 1 and 2, to this Regulation gives examples of arrangements of the approval mark with the above-mentioned additional symbols.

4.3.2. Grouped, combined or reciprocally incorporated lamps

4.3.2.1. Where grouped, combined or reciprocally incorporated lamps have been found to comply with the requirements of several Regulations, a single international approval mark may be provided, consisting of a circle surrounding the letter "E" followed by the distinguishing number of the country which has granted the approval, and an approval number. This approval mark may be located anywhere on the grouped, combined or reciprocally incorporated lamps, provided that:

4.3.2.1.1. it is visible after their installation;

4.3.2.1.2. no part of the grouped, combined or reciprocally incorporated lamps that transmits light can be removed without at the same time removing the approval mark.

4.3.2.2. The identification symbol for each lamp appropriate to each Regulation under which approval has been granted, together with the corresponding series of amendments incorporating the most recent major technical amendments to the Regulation at the time of issue of the approval and, if necessary, the required arrow shall be marked:

4.3.2.2.1. either on the appropriate light-emitting surface;

4.3.2.2.2. or in a group, in such a way that each of the grouped, combined or reciprocally incorporated lamps may be clearly identified.

4.3.2.3. The size of the components of a single approval mark shall not be less than the minimum size required for the smallest of the individual marks by the Regulation under which approval has been granted.

- 4.3.2.4. An approval number shall be assigned to each type approved. The same Contracting Party may not assign the same number to another type of grouped, combined or reciprocally incorporated lamps covered by this Regulation.
- 4.3.2.5. Annex 2, figure 3, to this Regulation gives examples of arrangements of approval marks for grouped, combined or reciprocally incorporated lamps with all the above-mentioned additional symbols.
- 4.3.3. Lamps, the lens of which is used for different types of lamps and which may be reciprocally incorporated or grouped with other lamps
The provisions laid down in paragraph 4.3.2. above are applicable.
- 4.3.3.1. In addition, where the same lens is used, the latter may bear the different approval marks relating to the different types of headlamps or units of lamps, provided that the main body of the headlamp, even if it cannot be separated from the lens, also comprises the space described in paragraph 3.2. above and bears the approval marks of the actual functions.
If different types of headlamps comprise the same main body, the latter may bear the different approval marks.
- 4.3.3.2. Annex 2, figure 4, to this Regulation gives examples of arrangements of approval marks for lamps reciprocally incorporated with a headlamp.

5. GENERAL SPECIFICATIONS

- 5.1. Each sample submitted in conformity with paragraph 2.2.3. above shall meet the specifications set forth in paragraphs 6 and 7 of this Regulation.
- 5.2. The front fog lamps shall be so designed and constructed that in normal use, despite the vibrations to which they may then be subjected, their satisfactory operation continues to be ensured and they retain the characteristics prescribed by this Regulation. The correct position of the lens shall be clearly marked and the lens and reflector shall be so secured as to prevent any rotation during use. Conformity with the requirements of this paragraph shall be verified by visual inspection and, where necessary, by a trial fitting.
- 5.2.1. Front fog lamps shall be fitted with a device enabling them to be so adjusted on the vehicles as to comply with the rules applicable to them. Such a device need not be fitted on units in which the reflector and the diffusing lens cannot be separated, provided the use of such units is confined to vehicles on which the front fog lamp setting can be adjusted by other means. Where a front fog lamp and another front lamp, each equipped with its own filament lamp, are assembled to form a composite unit, the adjusting device shall enable each optical system individually to be duly adjusted.
- 5.2.2. However, these provisions shall not apply to front lamp assemblies whose reflectors are indivisible. For this type of assembly the requirements of paragraph 6.6. of this Regulation shall apply.
- 5.3. Complementary tests shall be done according to the requirements of annex 4 to ensure that in use there is no excessive change in photometric performance.

5.4. If the lens of the front fog lamp is of plastic material, tests shall be done according to the requirements of annex 5.

6. ILLUMINATION

6.1. Front fog lamps shall be so designed as to provide illumination with limited dazzle.

6.2. The illumination produced by the front fog lamp shall be determined by means of a vertical screen set up 25 m forward of the lens of the front fog lamp. The point HV is the base of the perpendicular from the centre of the lamp to the screen. The line hh is the horizontal through HV (See annex 3 to this Regulation).

6.3. A colourless-bulb standard (reference) filament lamp of the category specified by the manufacturer, designed for a rated voltage of 12 V and supplied by the manufacturer, shall be used.

During the checking of the front fog lamp the voltage of the terminals of the filament lamp shall be regulated so as to obtain the following characteristics:

Filament lamp category	Approximate supply voltage (V) for measurement	Light flux in Lumens
H ₁	12	1,150
H ₂	12	1,300
H ₃	12	1,100
H ₄	12	750 *
H ₇	12	1,100
H ₈	12	600
HB ₃	12	1,300
HB ₄	12	825
H27W/1	12	350
H27W/2	12	350
H ₁₀	12	600

The front fog lamp shall be deemed satisfactory if the photometric requirements are met with at least one standard 12 V filament lamp.

6.4. The beam shall produce on the screen, over a width of not less than 2.25 m on both sides of the line VV, a symmetrical cut-off approximating sufficiently closely to the horizontal to enable adjustment to be performed with its aid.

6.5. The front fog lamp shall be so directed that the cut-off on the screen is 50 cm below the line hh.

6.6. When so adjusted, the front fog lamp shall meet the requirement set out in paragraph 6.7. below.

6.7. The illumination produced on the screen (see annex 3) shall meet the following requirements:

Position on measuring screen		Illumination required, in lux
Zone	Zone limits	
A	225 cm on both sides of the line VV and 75 cm above hh	> 0.15 and < 1
B	1,250 cm on both sides of the line VV and 150 cm above hh, including hh (except zone A)	< 1
C	1,250 cm on both sides of the line VV and starting from 150 cm above hh. The luminous intensity of the front fog lamp in any direction forming an angle of more than 15 degrees above the horizontal shall be limited to 200 cd.	< 0.5
D	450 cm on both sides of the line VV and comprised between the parallels to hh respectively situated 75 and 150 cm below hh	On each vertical line in this zone there shall be at least one point (a, b, c) where the illumination is > 1.5
E	From 450 cm to 1,000 cm on both sides of zone D and comprised between the parallels to hh respectively situated 75 and 150 cm below hh	On each vertical line in this zone there shall be at least one point where the illumination is > 0.5

Note: The illumination specifications also apply to the straight lines constituting the boundaries of the zones. The strictest specification shall be applied in respect to straight lines contiguous to two zones.

The illumination shall be measured either in white light or in coloured light as prescribed by the manufacturer for use of the front fog lamp in normal service. No variations in illumination detrimental to satisfactory visibility shall exist in either of the zones B and C.

- 6.8. The screen illumination referred to in paragraph 6.7. above shall be measured by means of a photo-electric cell having a useful area comprised within a square of 65 mm side.

7. COLOUR

Approval may be obtained for a type of front fog lamp emitting either white or yellow ^{4/} light. The colouring, if any, of the beam may be obtained either through the filament lamp bulb or through the lens of the front fog lamp or by any other suitable means.

8. DETERMINATION OF DISCOMFORT (DAZZLE)

The discomfort dazzle caused by the front fog lamp shall be determined. ^{5/}

9. OBSERVATION CONCERNING COLOUR

Any approval under this Regulation is granted, pursuant to paragraph 7 above, to a type of front fog lamp emitting either white or selective-yellow light; article 3 of the Agreement to which the Regulation is annexed shall accordingly not prevent the Contracting Parties from prohibiting the use on

^{4/} Same definition as for "selective yellow", but with a different purity factor: the limit towards white shall be: $y > -x + 0.940$ and $y > 0.440$ instead of: $y > -x + 0.966$, as for selective yellow.

^{5/} This determination will be the subject of a recommendation to Administrations.

vehicles registered by them of front fog lamps emitting a beam of white light or a beam of selective-yellow light. A front fog lamp approved for white light may also be approved for selective-yellow light under the same number, subject to a check of the colorimetric characteristics of the components enabling such colour to be obtained.

10. MODIFICATIONS OF THE TYPE OF FRONT FOG LAMP AND EXTENSION OF APPROVAL

- 10.1. Every modification of the type of front fog lamp shall be notified to the administrative department which approved the type of front fog lamp. The department may then either:
 - 10.1.1. Consider that the modifications made are unlikely to have an appreciable adverse effect and that in any case the front fog lamp still complies with the requirements; or
 - 10.1.2. Require a further test report from the technical service responsible for conducting the tests.
- 10.2. Confirmation or refusal of approval, specifying the alterations, shall be communicated by the procedure specified in paragraph 4.1.4. above the Parties to the Agreement which apply this Regulation.
- 10.3. The competent authority issuing the extension of approval shall assign a series number for such an extension and inform thereof the other Parties to the 1958 Agreement applying this Regulation by means of a communication form conforming to the model in annex 1 to this Regulation.

11. CONFORMITY OF PRODUCTION

- 11.1. Front fog lamps approved under this Regulation shall be so manufactured as to conform to the type approved by meeting the requirements set forth in paragraphs 6. and 7.
 - 11.2. In order to verify that the requirements of paragraph 11.1. are met, suitable controls of the production shall be carried out.
 - 11.3. The holder of the approval shall in particular:
 - 11.3.1. ensure the existence of procedures for the effective control of the quality of products;
 - 11.3.2. have access to the control equipment necessary for checking the conformity to each approved type;
 - 11.3.3. ensure that data of test results are recorded and that related documents shall remain available for a period to be determined in accordance with the administrative service;
 - 11.3.4. analyze the results of each type of test in order to verify and ensure the stability of the product characteristics making allowance for variation of an industrial production;
 - 11.3.5. ensure that for each type of product at least the tests prescribed in annex 6 to this Regulation are carried out;
 - 11.3.6. ensure that any collecting of samples giving evidence of non-conformity with the type of test considered shall give rise to another sampling and
-

another test. All the necessary steps shall be taken to re-establish the conformity of the corresponding production.

- 11.4. The competent authority which has granted type approval may at any time verify the conformity control methods applicable to each production unit.
 - 11.4.1. In every inspection, the test books and production survey records shall be presented to the visiting inspector.
 - 11.4.2. The inspector may take samples at random to be tested in the manufacturer's laboratory. The minimum number of samples may be determined in the light of the results of the manufacturer's own checks.
 - 11.4.3. When the quality level appears unsatisfactory or when it seems necessary to verify the validity of the tests carried out in the application of paragraph 11.4.2. above, the inspector shall select samples, to be sent to the technical service which has conducted the type approval tests, using the criteria of annex 7.
 - 11.4.4. The competent authority may carry out any test prescribed in this Regulation. These tests will be on samples selected at random without causing distortion of the manufacturer's delivery commitments and in accordance with the criteria of annex 7.
 - 11.4.5. The competent authority shall strive to obtain a frequency of inspection of once every two years. However, this is at the discretion of the competent authority and their confidence in the arrangements for ensuring effective control of the conformity of production. In the case where negative results are recorded, the competent authority shall ensure that all necessary steps are taken to re-establish the conformity of production as rapidly as possible.
- 11.5. Front fog lamps with apparent defects are disregarded.

12. PENALTIES FOR NON-CONFORMITY OF PRODUCTION

- 12.1. The approval granted in respect of a type of front fog lamp pursuant to this Regulation may be withdrawn if the requirements set forth above are not met, or if a front fog lamp bearing the approval mark does not conform to the type approved.
- 12.2. If a Contracting Party to the Agreement applying this Regulation withdraws an approval it has previously granted, it shall forthwith so notify the other Contracting Parties applying this Regulation, by means of a communication form conforming to the model in annex 1 to this Regulation.

13. PRODUCTION DEFINITELY DISCONTINUED

If the holder of the approval completely ceases to manufacture a front fog lamp approved in accordance with this Regulation, he shall so inform the authority which granted the approval. Upon receiving the relevant communication that authority shall inform thereof the other Parties to the 1958 Agreement which apply this Regulation, by means of a communication form conforming to the model in annex 1 to this Regulation.

14. NAMES AND ADDRESSES OF TECHNICAL SERVICES RESPONSIBLE FOR CONDUCTING APPROVAL TESTS, AND OF ADMINISTRATIVE DEPARTMENTS

The Parties to the 1958 Agreement which apply this Regulation shall communicate to the United Nations Secretariat the names and addresses of the technical services responsible for conducting approval tests and of the administrative departments which grant approval and to which forms certifying approval or extension or refusal or withdrawal of approval, or production definitely discontinued, issued in other countries, are to be sent.

15. TRANSITIONAL PROVISIONS

15.1. From the date of entry into force of the 02 series of amendments to this Regulation no Contracting Party applying it shall refuse to grant approvals under this Regulation as amended by the 02 series of amendments.

15.2. From 24 months after the date of entry into force mentioned in paragraph 15.1. above, Contracting Parties applying this Regulation shall grant approval only if the type of front fog lamp corresponds to the requirements of this Regulation as amended by the 02 series of amendments.

15.3. Existing approvals for front fog lamps as well as for H₁, H₂, H₃ and H₄, HB₃, HB₄ and H₇ filament lamps, already granted under this Regulation before the date mentioned in paragraph 15.2. above shall remain valid.

However, after the date of entry into force of this series of amendments, Contracting Parties applying this Regulation may prohibit the fitting of front fog lamps equipped with H₁, H₂, H₃ or H₄, HB₃, HB₄ and H₇ filament lamps if they do not satisfy the requirements of Regulation No. 37.

They may also prohibit the fitting of devices which do not meet the requirements of this Regulation as amended by the 02 series of amendments;

15.3.1. on vehicles for which type approval or individual approval is granted more than 24 months after the date of entry into force mentioned in paragraph 15.1. above,

15.3.2. on vehicles first registered more than 5 years after the date of entry into force mentioned in paragraph 15.1. above.

Annex 1
COMMUNICATION

(Maximum format: A4 (210 x 297 mm))

issued by: Name of administration:



.....
.....
.....

concerning: ^{2/} APPROVAL GRANTED

APPROVAL EXTENDED

APPROVAL REFUSED

APPROVAL WITHDRAWN

PRODUCTION DEFINITELY DISCONTINUED

of a type of motor vehicle front fog lamp pursuant to Regulation No. 19

Approval No.

Extension No.

1. Trade name or mark of the device:.....
2. Front fog lamp using a filament lamp category H₁, H₂, H₃, H₄, H₇, H₈, HB₃, HB₄, H_{27W/1}, H_{27W/2}, H₁₀: ^{2/}
3. Manufacturer's name and address:.....
4. If applicable, name and address of the manufacturer's representative:.....
5. Submitted for approval on:.....
6. Technical service responsible for conducting approval tests:.....
.....
7. Date of report issued by that service:.....
8. Number of test report issued by that service:.....
9. Brief description:
Category as described by the relevant marking: / B, B/, BPL, B/PL
Number and category of filament lamp(s):.....
Rated voltage (if sealed beam):.....
Colour of light emitted: white/yellow^{2/}
10. Position of the approval mark:.....

^{1/} Distinguishing number of the country which has granted/extended/refused/withdrawn approval (see approval provisions in the Regulation).

^{2/} Strike out what does not apply.

11. Reason(s) for extension (if applicable):.....
12. Approval granted/extended/refused/withdrawn: ^{2/}.....
13. Place:.....
14. Date:.....
15. Signature:.....
16. The list of documents deposited with the Administrative Service which has granted approval is annexed to this communication and may be obtained on request.

Annex 2

EXAMPLES OF ARRANGEMENTS OF APPROVAL MARKS

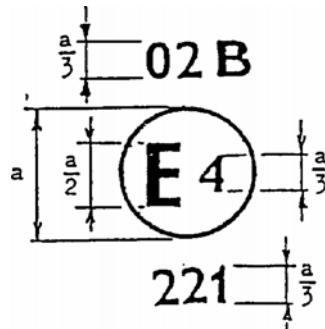

Figure 1

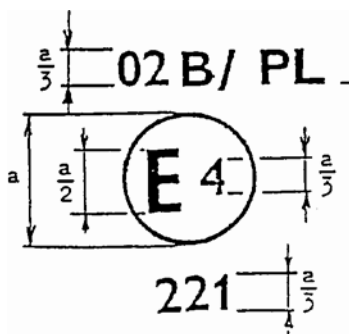
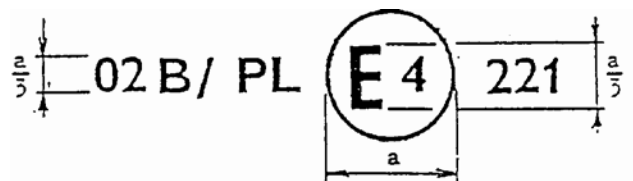

Figure 2a



a = 12mm min.

Figure 2b

The device bearing the above approval marking is a fog lamp approved in the Netherlands (E4) under number 221, in accordance with Regulation No. 19.

The number mentioned close to the symbol "B" indicates that the approval was granted in accordance with the requirements of Regulation No. 19 as amended by the 02 series of amendments.

Figure 1 indicates that the device is a front fog lamp which can be lit simultaneously with any other lamp with which it may be reciprocally incorporated.

Figures 2(a) and (b) indicate that the device is a front fog lamp incorporating a lens of plastic material and that it cannot be lit simultaneously with any other lamp with which it may be reciprocally incorporated. Note: The approval number and the additional symbols shall be placed close to the circle and either above or below the letter "E", or to the right or left of that letter. The digits of the approval number shall be on the same side of the letter "E" and face the same direction. The use of Roman numerals as approval numbers should be avoided so as to prevent any confusion with other symbols.

Examples of possible markings for grouped, combined or reciprocally incorporated lamps situated on the front of a vehicle

Figure 3

The vertical and horizontal lines schematize the shape of the light-signalling device. These are not part of the approval mark.

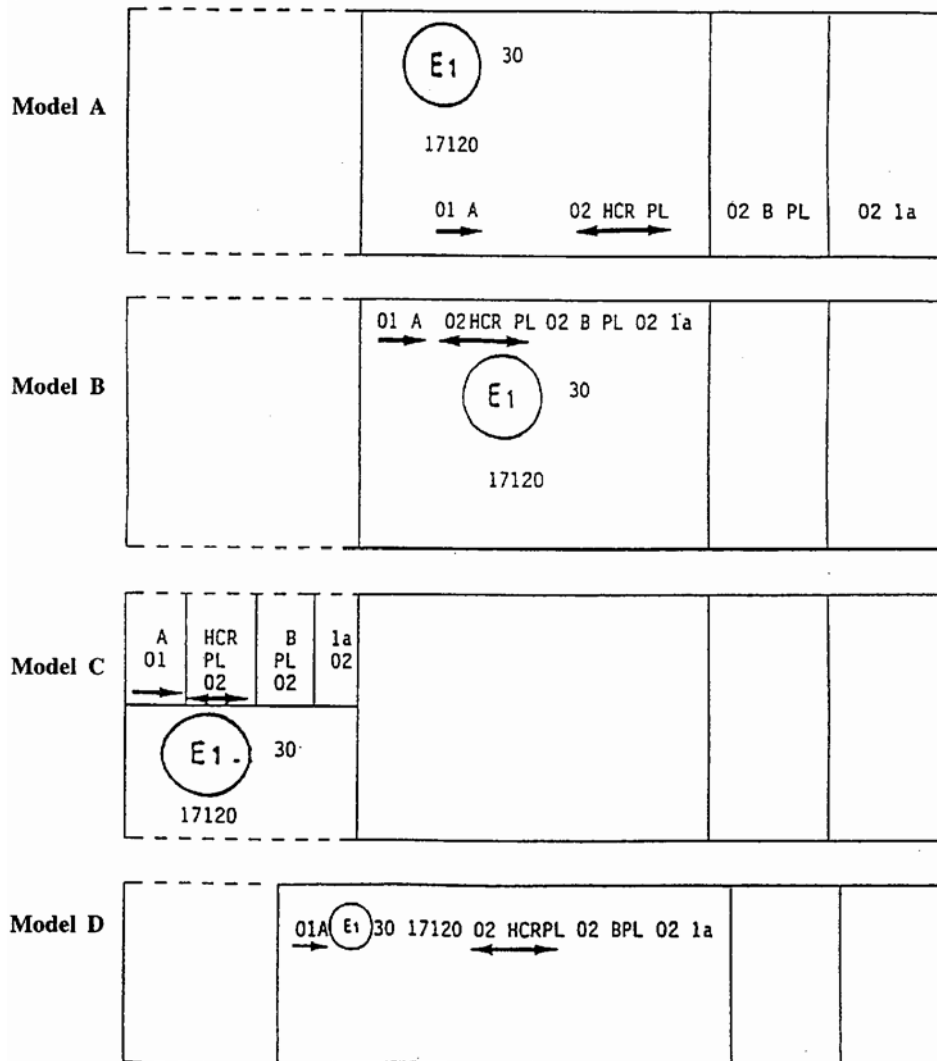

Note: The four examples shown above correspond to a lighting device bearing an approval mark relating to :

A front position lamp approved in accordance with the 01 series of amendments to Regulation No. 7;

A headlamp with a passing beam designed for right-hand and left-hand traffic and a driving beam with a maximum intensity comprised between 86,250 and 101,250 candelas (as indicated by the number 30) approved in accordance with the 02 series of amendments to Regulation No. 20 and incorporating a lens of plastic material;

A front fog lamp approved in accordance with the 02 series of amendments to Regulation No. 19 and incorporating a lens of plastic material;

A front direction indicator lamp of category 1a approved in accordance with the 02 series of amendments to Regulation No. 6.

Lamp reciprocally incorporated with a headlamp

Figure 4

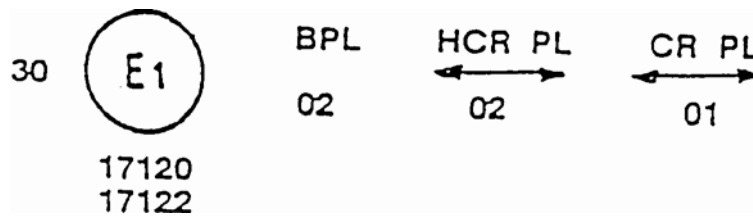

The above example corresponds to the marking of a lens of plastic material intended to be used in different types of headlamps, namely:

either: a headlamp with a passing beam designed for right-hand and left-hand traffic and a driving beam with a maximum intensity comprised between 86,250 and 101,250 candelas, approved in Germany (E1) in accordance with the requirements of Regulation No. 20 as amended by the 02 series of amendments, which is reciprocally incorporated with a front fog lamp approved in accordance with the 02 series of amendments to Regulation No. 19;

or: a headlamp with a passing beam designed for right-hand and left-hand traffic and a driving beam, approved in Germany (E1) in accordance with the requirements of Regulation No. 1 as amended by the 01 series of amendments, which is reciprocally incorporated with the same front fog lamp as above;

or even: either of the above-mentioned headlamps approved as a single lamp.

The main body of the headlamp shall bear only valid approval number, for instance:

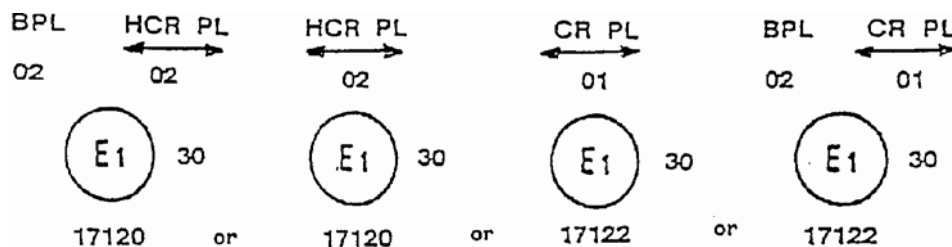

Annex 3
MEASURING SCREEN

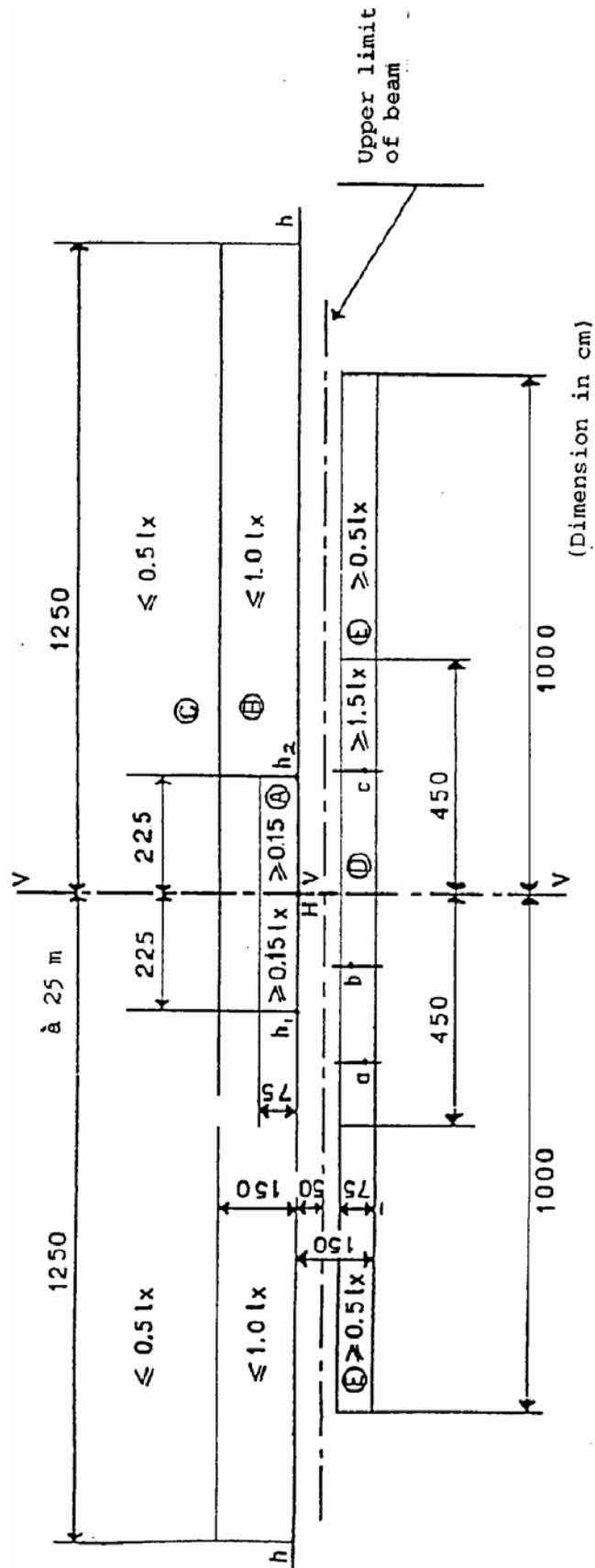

HV: point of intersection of lines hh and VV

Annex 4

TEST FOR STABILITY OF PHOTOMETRIC PERFORMANCE OF HEADLAMPS IN OPERATION

TESTS ON COMPLETE HEADLAMPS

Once the photometric values have been measured according to the prescriptions of this Regulation, in the point of maximum illumination in zone D (E_{\max}) and in point HV, a complete headlamp sample shall be tested for stability of photometric performance in operation. "Complete headlamp" shall be understood to mean the complete lamp itself including those surrounding body parts and lamps which could influence its thermal dissipation.

1. TEST FOR STABILITY OF PHOTOMETRIC PERFORMANCE

The tests shall be carried out in a dry and still atmosphere at an ambient temperature of 23 degrees C +/- 5 degrees C, the complete headlamp being mounted on a base representing the correct installation on the vehicle.

1.1. Clean headlamp

The headlamp shall be operated for 12 hours as described in subparagraph 1.1.1. and checked as prescribed in subparagraph 1.1.2.

1.1.1. Test procedure

The headlamp shall be operated for the specified time so that: ^{1/}

- 1.1.1.1. (a) in the case where only a front fog lamp is to be approved, the corresponding filament lamp(s) is (are) lit for the prescribed time;
- (b) In the case of a front fog lamp reciprocally incorporated with another function: If the applicant declares that the headlamp is to be used with a single filament lit^{1/} at a time, the test shall be carried out in accordance with this condition, activating each specified function successively for half the time specified in paragraph 1.1.; In all other cases, ^{1/} the headlamp shall be subjected to the following cycle until the time specified is reached:

15 minutes, front fog lamp filament(s) lit

5 minutes, all filaments (that can be lit simultaneously);

- (c) In the case of grouped lighting functions all the individual functions shall be lit simultaneously for the time specified for individual lighting functions (a), also taking into account the use of reciprocally incorporated lighting functions, according to the manufacturer's specifications.

1.1.1.2. Test voltage

The voltage of the filament lamp shall be adjusted so as to supply 90 % of

^{1/} Should two or more filaments be simultaneously lit when headlamp flashing is used, this shall not be considered as being normal use of the filaments simultaneously. When the tested headlamp is grouped and/or reciprocally incorporated with signalling lamps, the latter shall be lit for the duration of the test. In the case of a direction indicator lamp, it shall be lit in flashing operation mode with an on/off time ratio of approximately one to one.

the maximum wattage specified in the Regulation for filament lamps (Regulation No. 37).

The applied wattage shall in all cases comply with the corresponding value of a filament lamp of 12 V rated voltage, except if the applicant for approval specifies that the headlamp may be used at a different voltage. In the latter case, the test shall be carried out with the filament lamp of which the wattage is the highest that can be used.

1.1.2. Test results

1.1.2.1. Visual inspection

Once the headlamp has been stabilized to the ambient temperature, the headlamp lens and the external lens, if any, shall be cleaned with a clean, damp cotton cloth. It shall then be inspected visually; no distortion, deformation, cracking or change in colour of either the headlamp lens or the external lens, if any, shall be noticeable.

1.1.2.2. Photometric test

To comply with the requirements of this Regulation, the following photometric values shall be verified in the following points:

HV, and point of Emax in zone D.

Another aiming may be carried out to allow for any deformation of the headlamp base due to heat (the change of the position of the cut-off line is covered in paragraph 2). A 10 % discrepancy between the photometric characteristics and the values measured prior to the test is permissible including the tolerances of the photometric procedure.

1.2. Dirty headlamp

After being tested as specified in subparagraph 1.1. above, the headlamp shall be operated for one hour as described in subparagraph 1.1.1., after being prepared as prescribed in subparagraph 1.2.1., and checked as prescribed in subparagraph 1.1.2.

1.2.1. Preparation of the headlamp

1.2.1.1. Test mixture

1.2.1.1.1. For headlamp with the outside lens in glass:

The mixture of water and a polluting agent to be applied to the headlamp shall be composed of:

9 parts by weight of silica sand with a particle size of 0-100 µm,

1 part by weight of vegetal carbon dust (beechwood) with a particle size of 0-100 µm, 0.2 part by weight of NaCMC^{2/} and

an appropriate quantity of distilled water, with a conductivity of < 1 mS/m.

The mixture must not be more than 14 days old.

^{2/} NaCMC represents the sodium salt of carboxymethylcellulose, customarily referred to as CMC. The NaCMC used in the dirt mixture shall have a degree of substitution (DS) of 0.6-0.7 and a viscosity of 200-300 cP for a 2 % solution at 20 degrees C.

1.2.1.1.2. For headlamp with outside lens in plastic material:

The mixture of water and polluting agent to be applied to the headlamp shall be composed of:

9 parts by weight of silica sand with a particle size of 0-100 μm ,

1 part by weight of vegetal carbon dust (beechwood) with a particle size of 0-100 μm , 0.2 part by weight of NaCMC ^{2/},

13 parts by weight of distilled water with a conductivity of < 1 mS/m, and

2 +/- 1 parts by weight of surface-actant.^{3/}

The mixture must not be more than 14 days old.

1.2.1.2. Application of the test mixture to the headlamp

The test mixture shall be uniformly applied to the entire light emitting surface of the headlamp and then left to dry. This procedure shall be repeated until the illumination value has dropped to 15-20 % of the values measured for the following point under the conditions described in this annex: point of Emax in zone D.

1.2.1.3. Measuring equipment

The measuring equipment shall be equivalent to that used during headlamp approval tests. A standard (reference) filament lamp shall be used for the photometric verification.

2. TEST FOR CHANGE IN VERTICAL POSITION OF THE CUT-OFF LINE UNDER THE INFLUENCE OF HEAT

This test consists of verifying that the vertical drift of the cut-off line under the influence of heat does not exceed the specified value for an operating front fog lamp.

The headlamp tested in accordance with paragraph 1, shall be subjected to the test described in 2.1., without being removed from or readjusted in relation to its test fixture.

2.1. Test

The test shall be carried out in a dry and still atmosphere at an ambient temperature of 23 degrees C +/- 5 degrees C.

Using a mass production filament lamp which has been aged for at least one hour the headlamp shall be operated without being dismantled from or readjusted in relation to its test fixture. (For the purpose of this test, the voltage shall be adjusted as specified in paragraph 1.1.1.2.). The position of the cut-off line between a point situated 2.25 m left and a point situated 2.25 m right of the line VV (see paragraph 6.4. of the Regulation) shall be verified after three minutes (r_3) and 60 minutes (r_{60}) respectively of operation. The measurement of the variation in the cut-off line position as described above shall be carried out by any method giving acceptable accuracy and reproducible results.

^{3/} The tolerance on quantity is due to the necessity of obtaining a dirt that correctly spreads out on all the plastic lens.

2.2. Test results

2.2.1. The result expressed in milliradians (mrad) shall be considered acceptable when the absolute value $\Delta r_I = (r_3 - r_{60})$ recorded on this headlamp is not more than 2 mrad ($\Delta r_I < 2$ mrad).

2.2.2. However, if this value is more than 2 mrad but not more than 3 mrad ($2 \text{ mrad} < \Delta r_I < 3 \text{ mrad}$) a second headlamp shall be tested as described in paragraph 2.1 after being subjected three consecutive times to the cycle as described below, in order to stabilize the position of mechanical parts of the headlamp on a base representative of the correct installation on the vehicle:

Operation of the front fog lamp for one hour (the voltage shall be adjusted as specified in paragraph 1.1.1.2.).

Period of rest for one hour.

The headlamp type shall be considered acceptable if the mean value of the absolute values Δr_I measured on the first sample and Δr_{II} measured on the second sample is not more than 2 mrad.

$$\frac{\Delta r_I + \Delta r_{II}}{2} \leq 2 \text{ mrad}$$

Annex 5

REQUIREMENTS FOR LAMPS INCORPORATING LENSES OF PLASTIC MATERIAL - TESTING OF LENS OR MATERIAL SAMPLES AND OF COMPLETE LAMPS

1.

GENERAL SPECIFICATIONS

1.1.

The samples supplied pursuant to paragraph 2.2.4. of this Regulation shall satisfy the specifications indicated in paragraphs 2.1. to 2.5. below.

1.2.

The two samples of complete lamps supplied pursuant to paragraph 2.2.3. of this Regulations and incorporating lenses of plastic material shall, with regard to the lens material, satisfy the specifications indicated in paragraph 2.6. below.

1.3.

The samples of lenses of plastic material or samples of material shall be subjected, with the reflector to which they are intended to be fitted (where applicable), to approval tests in the chronological order indicated in table A reproduced in appendix 1 to this annex.

1.4.

However, if the lamp manufacturer can prove that the product has already passed the tests prescribed in paragraphs 2.1.-2.5. below, or the equivalent tests pursuant to another Regulation, those tests need not be repeated; only the tests prescribed in appendix 1, table B, shall be mandatory.

2.

TESTS

2.1.

Resistance to temperature changes

2.1.1.

Tests

Three new samples (lenses) shall be subjected to five cycles of temperature and humidity (RH = relative humidity) change in accordance with the following programme. 3 hours at 40 degrees C +/- 2 degrees C and 85-95 % RH;

1 hour at 23 degrees C +/- 5 degrees C and 60-75 % RH;

15 hours at -30 degrees C +/- 2 degrees C;

1 hour at 23 degrees C +/- 5 degrees C and 60-75 % RH;

3 hours at 80 degrees C +/- 2 degrees C;

1 hour at 23 degrees C +/- 5 degrees C and 60-75 % RH;

Before this test, the samples shall be kept at 23 degrees C +/- 5 degrees C and 60-75 % RH for at least four hours.

Note:

The periods of one hour at 23 degrees C +/- 5 degrees C shall include the periods of transition from one temperature to another which are needed in order to avoid thermal shock effects.

2.1.2.

Photometric measurements

2.1.2.1.

Method

Photometric measurements shall be carried out on the samples before and after the test. These measurements shall be made using a standard lamp, at the following points: HV and Emax zone D.

2.1.2.2.

Results

The variation between the photometric values measured on each sample before and after the test shall not exceed 10 % including the tolerances of the photometric procedure.

2.2.

Resistance to atmospheric and chemical agents

2.2.1.

Resistance to atmospheric agents

Three new samples (lenses or samples of material) shall be exposed to radiation from a source having a spectral energy distribution similar to that of a black body at a temperature between 5,500K and 6,000K. Appropriate filters shall be placed between the source and the samples so as to reduce as far as possible radiations with wave lengths smaller than 295 nm and greater than 2,500 nm. The samples shall be exposed to an energetic illumination of 1,200 W/m² +/- 200 W/m² for a period such that the luminous energy that they receive is equal to 4,500 MJ/m² +/- 200 MJ/m². Within the enclosure, the temperature measured on the black panel placed on a level with the samples shall be 50 degrees C +/- 5 degrees C. In order to ensure a regular exposure, the samples shall revolve around the source of radiation at a speed between 1 and 5 l/min.

The samples shall be sprayed with distilled water of conductivity lower than 1 mS/m at a temperature of 23 degrees C +/- 5 degrees C, in accordance with the following cycle: spraying: 5 minutes;

drying: 25 minutes.

2.2.2.

Resistance to chemical agents

After the test described in paragraph 2.2.1. above and the measurement described in paragraph 2.2.3.1. below have been carried out, the outer face of the said three samples shall be treated as described in paragraph 2.2.2.2. with the mixture defined in paragraph 2.2.2.1. below.

2.2.2.1. Test mixture

The test mixture shall be composed of 61.5 % n-heptane, 12.5 % toluene, 7.5 % ethyl tetrachloride, 12.5 % trichlorethylene and 6 % xylene (volume %).

2.2.2.2. Application of the test mixture

Soak a piece of cotton cloth (as per ISO 105) until saturation with the mixture defined in paragraph 2.2.2.1. above and, within 10 seconds, apply it for 10 minutes to the outer face of the sample at a pressure of 50 N/cm², corresponding to an effort of 100 N applied on a test surface of 14 x 14 mm.

During this 10-minute period, the cloth pad shall be soaked again with the mixture so that the composition of the liquid applied is continuously identical with that of the test mixture prescribed.

During the period of application, it is permissible to compensate the pressure applied to the sample in order to prevent it from causing cracks.

2.2.2.3. Cleaning

At the end of the application of the test mixture, the samples shall be dried in the open air and then washed with the solution described in paragraph 2.3. (Resistance to detergents) at 23 degrees C +/- 5 degrees C.

Afterwards the samples shall be carefully rinsed with distilled water containing not more than 0.2 % impurities at 23 degrees C +/- 5 degrees C and then wiped off with a soft cloth.

2.2.3. Results

2.2.3.1. After the test of resistance to atmospheric agents, the outer face of the samples shall be free from cracks, scratches, chipping and deformation, and the mean variation in transmission.

$$\Delta t = \frac{T2 - T3}{T2}$$

measured on the three samples according to the procedure described in appendix 2 to this annex shall not exceed 0.020 ($\Delta t_m < 0.020$).

2.2.3.2. After the test of resistance to chemical agents, the samples shall not bear any traces of chemical staining likely to cause a variation of flux diffusion, whose mean variation

$$\Delta d = \frac{T5 - T4}{T2}$$

measured on the three samples according to the procedure described in appendix 2 to this annex shall not exceed 0.020 ($Dd_m < 0.020$).

2.3. Resistance to detergents and hydrocarbons

2.3.1. Resistance to detergents

The outer face of three samples (lenses or samples of material) shall be heated to 50 degrees C +/- 5 degrees C and then immersed for five minutes in a mixture maintained at 23 degrees C +/- 5 degrees C and composed of 99 parts distilled water containing not more than 0.02 % impurities and one part alkylaryl sulphonate.

At the end of the test, the samples shall be dried at 50 degrees C +/- 5 degrees C. The surface of the samples shall be cleaned with a moist cloth.

2.3.2. Resistance to hydrocarbons

The outer face of these three samples shall then be lightly rubbed for one minute with a cotton cloth soaked in a mixture composed of 70 % n-heptane and 30 % toluene (volume %), and shall then be dried in the open air.

2.3.3. Results

After the above two tests have been performed successively, the mean value of the variation in transmission

$$\Delta t = \frac{T2 - T3}{T2}$$

measured on the three samples according to the procedure described in appendix 2 to this annex shall not exceed 0.010 ($D_{tm} < 0.010$).

2.4. Resistance to mechanical deterioration

2.4.1. Mechanical deterioration method

The outer face of the three new samples (lenses) shall be subjected to the uniform mechanical deterioration test by the method described in appendix 3 to this annex.

2.4.2. Results

After this test, the variations:

$$\Delta t = \frac{T2 - T3}{T2}$$

and in diffusion:

$$\Delta d = \frac{T5 - T4}{T2}$$

shall be measured according to the procedure described in appendix 2 in the area specified in paragraph 2.2.4.1.1 above. The mean value of the three samples shall be such that:

$$D_{tm} < 0.100;$$

$$D_{dm} < 0.050.$$

2.5. Test of adherence of coatings, if any

2.5.1. Preparation of the sample

A surface of 20 mm x 20 mm in area of the coating of a lens shall be cut with a razor blade or a needle into a grid of squares approximately 2 mm x 2 mm. The pressure on the blade or needle shall be sufficient to cut at least the coating.

2.5.2. Description of the test

Use an adhesive tape with a force of adhesion of 2 N/(cm of width) +/- 20 % measured under the standardized conditions specified in appendix 4 to this annex. This adhesive tape, which shall be at least 25 mm wide, shall be pressed for at least five minutes to the surface prepared as prescribed in paragraph 2.5.1.

Then the end of the adhesive tape shall be loaded in such a way that the force of adhesion to the surface considered is balanced by a force perpendicular to that surface. At this stage, the tape shall be torn off at a constant speed of 1.5 m/s +/- 0.2 m/s.

2.5.3. Results

There shall be no appreciable impairment of the gridded area. Impairments at the intersections between squares or at the edges of the cuts shall be permitted, provided that the impaired area does not exceed 15 % of the gridded surface.

2.6. Tests of the complete lamp incorporating a lens of plastic material

2.6.1. Resistance to mechanical deterioration of the lens surface

2.6.1.1. Tests

The lens of lamp sample No. 1 shall be subjected to the test described in paragraph 2.4.1. above.

2.6.1.2. Results

After the test, the results of photometric measurements carried out on the lamp in accordance with this Regulation shall not exceed by more than 30 % the maximum values prescribed in zones A and B.

2.6.2. Test of adherence of coatings, if any

The lens of lamp sample No. 2 shall be subjected to the test described in paragraph 2.5. above.

3. VERIFICATION OF THE CONFORMITY OF PRODUCTION

3.1. With regard to the materials used for the manufacture of lenses, the lamps of a series shall be recognized as complying with this Regulation if:

3.1.1. After the test for resistance to chemical agents and the test for resistance to detergents and hydrocarbons, the outer face of the samples exhibits no cracks, chipping or deformation visible to the naked eye (see paragraphs 2.2.2., 2.3.1. and 2.3.2.);

- 3.1.2. After the test described in paragraph 2.6.1.1., the photometric values at the points of measurement considered in paragraph 2.6.1.2. are within the limits prescribed for conformity of production by this Regulation.
- 3.2. If the test results fail to satisfy the requirements, the tests shall be repeated on another sample of headlamps selected at random.

Annex 5 - Appendix 1

CHRONOLOGICAL ORDER OF APPROVAL TESTS

A. Tests on plastic materials (lenses or samples of material supplied pursuant to paragraph 2.2.4. of this Regulation).

Tests	Sample	Lenses or samples						Samples						
		1	2	3	4	5	6	7	8	9	10	11	12	13
1.1. Limited photometry (para. 2.1.1.)											x	x	x	
1.1.1. Temperature change (para. 2.1.1)											x	x	x	
1.1.2. Limited photometry(para. 2.1.2)											x	x	x	
1.2.1. Transmission measurement		x	x	x	x	x	x	x	x	x				
1.2.2. Diffusion measurement		x	x	x				x	x	x				
1.3. Atmospheric agents(para. 2.2.1)		x	x	x										
1.3.1. Transmission measurement		x	x	x										
1.4. Chemicals agents(para. 2.2.2)		x	x	x										
1.4.1. Diffusion measurement		x	x	x										
1.5. Detergents(para. 2.3.1)					x	x	x							
1.6. Hydrocarbons(para. 2.3.2)					x	x	x							
1.6.1. Transmission measuremen					x	x	x							
1.7. Deterioration (para. 2.4.1)								x	x	x				
1.7.1. Transmission measurement								x	x	x				
1.7.2. Diffusion measurement								x	x	x				
1.8. Adherence(para. 2.5)														x

B. Tests on complete lamps (supplied pursuant to paragraph 2.2.3. of this Regulation).

Test	Complete headlamp	
	Sample No.	
	1	2
2.1. Deterioration (para. 2.6.1.1.)	X	
2.2. Photometry (para. 2.6.1.2.)	X	
2.3. Adherence (para. 2.6.2.)		X

Annex 5 - Appendix 2

METHOD OF MEASUREMENT OF THE DIFFUSION AND TRANSMISSION OF LIGHT

1. EQUIPMENT (see figure)

The beam of a collimator K with a half divergence

$$\frac{\beta}{2} = 17.4 \times 10^{-4} \text{ rd}$$

is limited by a diaphragm DT with an opening of 6 mm against which the sample stand is placed.

A convergent achromatic lens L₂, corrected for spherical aberrations, links the diaphragm D_T with the receiver R; the diameter of the lens L₂ shall be such that it does not diaphragm the light diffused by the sample in a cone with a half top angle of $\beta/2 = 14$ degrees.

An annular diaphragm D_D with angles

$$\frac{\alpha_0}{2} = 1^\circ$$

and

$$\frac{\alpha_{\max}}{2} = 12^\circ$$

is placed in an image focal plane of the lens L₂.

The non-transparent central part of the diaphragm is necessary in order to eliminate the light arriving directly from the light source. It shall be possible to remove the central part of the diaphragm from the light beam in such a manner that it returns exactly to its original position.

The distance L₂ D_T and the focal length F₂^{1/} of the lens L₂ shall be so chosen that the image of D_T completely covers the receiver R.

When the initial incident flux is referred to 1,000 units, the absolute precision of each reading shall be better than 1 unit.

2. MEASUREMENTS

The following readings shall be taken:

Reading	With sample	With central part of D _D	Quantity represented
T ₁	No	No	Incident flux in initial reading
T ₂	Yes (before test)	No	Flux transmitted by the new material in a field of 24 degrees C
T ₃	Yes (after test)	No	Flux transmitted by the tested material in a field of 24 degrees C
T ₄	Yes (before test)	Yes	Flux diffused by the new material
T ₅	Yes (after test)	Yes	Flux diffused by the tested material

^{1/} For L₂ it is recommended to use a focal distance of about 80 mm.

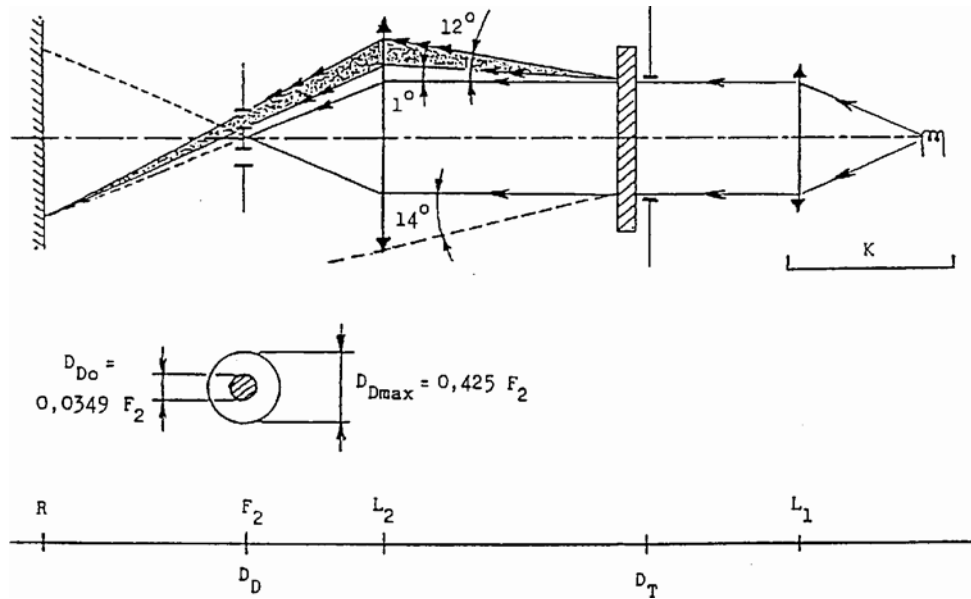

Annex 5 - Appendix 3

SPRAY TESTING METHOD

1. Test equipment

1.1. Spray gun

The spray gun used shall be equipped with a nozzle 1.3 mm in diameter allowing a liquid flow rate of 0.24 +/- 0.02 l/minute at an operating pressure of 6.0 bars - 0, + 0.5 bar. Under these operation conditions the fan pattern obtained shall be 170 mm +/- 50 mm in diameter on the surface exposed to deterioration, at a distance of 380 mm +/- 10 mm from the nozzle.

1.2. Test mixture

The test mixture shall be composed of:

Silica sand of hardness 7 on the Mohs scale, with a grain size between 0 and 0.2 mm and an almost normal distribution, with an angular factor of 1.8 to 2;

Water of hardness not exceeding 205 g/m³ for a mixture comprising 25 g of sand per litre of water.

2. Test

The outer surface of the lamp lenses shall be subjected once or more than once to the action of the sand jet produced as described above. The jet shall be sprayed almost perpendicular to the surface to be tested.

The deterioration shall be checked by means of one or more samples of glass placed as a reference near the lenses to be tested. The mixture shall be sprayed until the variation in the diffusion of light on the sample or samples measured by the method described in appendix 2, is such that:

$$\Delta d = \frac{T5 - T4}{T2} = 0.0250 \pm 0.0025$$

Several reference samples may be used to check that the whole surface to be tested has deteriorated homogeneously.

Annex 5 - Appendix 4

ADHESIVE TAPE ADHERENCE TEST

1. PURPOSE

This method allows to determine under standard conditions the linear force of adhesion of an adhesive tape to a glass plate.

2. PRINCIPLE

Measurement of the force necessary to unstick an adhesive tape from a glass plate at an angle of 90 degrees.

3. SPECIFIED ATMOSPHERIC CONDITIONS

The ambient conditions shall be at 23 degrees C +/- 5 degrees C and 65 +/- 15 % relative humidity (RH).

4. TEST PIECES

Before the test, the sample roll of adhesive tape shall be conditioned for 24 hours in the specified atmosphere (see para. 3 above).

Five test pieces each 400 mm long shall be tested from each roll. These test pieces shall be taken from the roll after the first three turns were discarded.

5. PROCEDURE

The test shall be under the ambient conditions specified in paragraph 3.

Take the five test pieces while unrolling the tape radially at a speed of approximately 300 mm/s, then apply them within 15 seconds in the following manner:

Apply the tape to the glass plate progressively with a slight lengthwise rubbing movement of the finger, without excessive pressure, in such a manner as to leave no air bubble between the tape and the glass plate.

Leave the assembly in the specified atmospheric conditions for 10 minutes.

Unstick about 25 mm of the test piece from the plate in a plane perpendicular to the axis of the test piece.

Fix the plate and fold back the free end of the tape at 90 degrees. Apply force in such a manner that the separation line between the tape and the plate is perpendicular to this force and perpendicular to the plate.

Pull to unstick at a speed of 300 mm/s +/- 30 mm/s and record the force required.

6. RESULTS

The five values obtained shall be arranged in order and the median value taken as the result of the measurement. This value shall be expressed in Newtons per centimetre of width of the tape.

Annex 6

MINIMUM REQUIREMENTS FOR CONFORMITY OF PRODUCTION CONTROL PROCEDURES

1. GENERAL

- 1.1. The conformity requirements shall be considered satisfied from a mechanical and geometric standpoint, if the differences do not exceed inevitable manufacturing deviations within the requirements of this Regulation.
- 1.2. With respect to photometric performances, the conformity of mass-produced front fog lamps shall not be contested if, when testing photometric performances of any front fog lamp chosen at random and equipped with a standard filament lamp no measured value deviates unfavourably by more than 20 % from the value prescribed in this Regulation (points B 50 and left and right bottom corners of zone D);

If the results of the tests described above do not meet the requirements, tests on the front fog lamp shall be repeated using another standard filament lamp.

- 1.3. With respect to the verification of the change in vertical position of the cut-off line under the influence of heat, the following procedure shall be applied:

One of the sampled front fog lamps shall be tested according to the procedure described in paragraph 2.1. of annex 4 after being subjected three consecutive times to the cycle described in paragraph 2.2.2. of annex 4.

The front fog lamp shall be considered as acceptable if D_r does not exceed 3.0 mrad.

If this value exceeds 3.0 mrad but is not more than 4.0 mrad, a second front fog lamp shall be subjected to the test after which the mean of the absolute values recorded on both samples shall not exceed 3.0 mrad.

- 1.4. The chromaticity coordinates shall be complied with when the front fog lamp is equipped with a filament lamp set to Standard A colour temperature.

The photometric performance of a front fog lamp emitting enlarged selective yellow light when equipped with a colourless filament lamp shall be the values contained in this Regulation multiplied by 0.84.

2. MINIMUM REQUIREMENTS FOR VERIFICATION OF CONFORMITY BY THE MANUFACTURER

For each type of front fog lamp the holder of the approval mark shall carry out at least the following tests, at appropriate intervals. The tests shall be carried out in accordance with the provisions of this Regulation.

If any sampling shows non-conformity with regard to the type of test concerned, further samples shall be taken and tested. The manufacturer shall take steps to ensure the conformity of the production concerned.

2.1. Nature of tests

Tests of conformity in this Regulation shall cover the photometric characteristics and the verification of the change in vertical position of the cut-off line under the influence of heat.

2.2. Methods used in tests

2.2.1. Tests shall generally be carried out in accordance with the methods set out in this Regulation.

2.2.2. In any test of conformity carried out by the manufacturer, equivalent methods may be used with the consent of the competent authority responsible for approval tests. The manufacturer is responsible for proving that the applied methods are equivalent to those laid down in this Regulation.

2.2.3. The application of paragraphs 2.2.1. and 2.2.2. requires regular calibration of test apparatus and its correlation with measurements made by a competent authority.

2.2.4. In all cases the reference methods shall be those of this Regulation, particularly for the purpose of administrative verification and sampling.

2.3. Nature of sampling

Samples of front fog lamps shall be selected at random from the production of a uniform batch. A uniform batch means a set of front fog lamps of the same type, defined according to the production methods of the manufacturer.

The assessment shall in general cover series production from individual factories. However, a manufacturer may group together records concerning the same type from several factories, provided these operate under the same quality system and quality management.

2.4. Measured and recorded photometric characteristics

The sampled front fog lamp shall be subjected photometric measurements at the points provided for in the Regulation, the reading being limited to points B 50 and left and right bottom corners of zone D (see figure in annex 3).

2.5. Criteria governing acceptability

The manufacturer is responsible for carrying out a statistical study of the test results and for defining, in agreement with the competent authority, criteria governing the acceptability of his products in order to meet the specifications laid down for verification of conformity of products in paragraph 11.1. of this Regulation.

The criteria governing the acceptability shall be such that, with a confidence level of 95 %, the minimum probability of passing a spot check in accordance with annex 7 (first sampling) would be 0.95.

Annex 7

MINIMUM REQUIREMENTS FOR SAMPLING BY AN INSPECTOR

1. GENERAL

- 1.1. The conformity requirements shall be considered satisfied from a mechanical and a geometric standpoint, in accordance with the requirements of this Regulation, if any, if the differences do not exceed inevitable manufacturing deviations.
- 1.2. With respect to photometric performance, the conformity of mass-produced front fog lamps shall not be contested if, when testing photometric performances of any front fog lamp chosen at random and equipped with a standard filament lamp no measured value deviates unfavourably by more than 20 % from the values prescribed in this Regulation (points B 50 and left and right bottom corners of zone D).
- 1.2.1. If the results of the tests described above do not meet the requirements, tests on the front fog lamp shall be repeated using another standard filament lamp.
- 1.2.2. Front fog lamps with apparent defects are disregarded.
- 1.3. The chromaticity coordinates shall be complied with when the front fog lamp is equipped with a filament lamp set to Standard A colour temperature.

The photometric performance of a front fog lamp emitting enlarged selective yellow light when equipped with a colourless filament lamp shall be multiplied by 0.84.

2. FIRST SAMPLING

In the first sampling four front fog lamps are selected at random. The first sample of two is marked A, the second sample of two is marked B.

2.1. The conformity is not contested

- 2.1.1. Following the sampling procedure shown in Figure 1 of this annex the conformity of mass-produced front fog lamps shall not be contested if the deviation of the measured values of the front fog lamps in the unfavourable directions are:

2.1.1.1. sample A

- A1: one front fog lamp..... 0 %
one front fog lamp not more than.....20 %
- A2: both front fog lamps more than 0 %
but not more than20 %

go to sample B

2.1.1.2. sample B

- B1: both front fog lamps 0 %

2.2. The conformity is contested

2.2.1. Following the sampling procedure shown in Figure 1 of this annex the conformity of mass-produced front fog lamps shall be contested and the manufacturer requested to make his productions meet the requirements (alignment) if the deviations of the measured values of the front fog lamps are:

2.2.1.1. sample A:

- A3: one front fog lamp not more than.....20 %
one front fog lamp more than.....20 %
but not more than.....30 %

2.2.1.2. sample B:

B2: in the case of A2

- one front fog lamp more than..... 0 %
but not more than.....20 %
one front fog lamp not more than.....20 %

B3: in the case of A2

- one front fog lamp..... 0 %
one front fog lamp more than.....20 %
but not more than.....30

2.3. Approval withdrawn

Conformity shall be contested and paragraph 12 applied if, following the sampling procedure in Figure 1 of this annex, the deviations of the measured values of the front fog lamps are:

2.3.1. sample A

- A4: one front fog lamp not more than.....20 %
one front fog lamp more than.....30 %
- A5: both front fog lamps more than.....20 %

2.3.2. sample B

B4: in the case of A2

- one front fog lamp more than.....0 %
but not more than.....20 %
one front fog lamp more than.....20 %

B5: in the case of A2

- both front fog lamps more than.....20 %

B6: in the case of A2

- one front fog lamp.....0 %
- one front fog lamp more than.....30 %

3. REPEATED SAMPLING

In the cases of A3, B2, B3 a repeated sampling, third sample C of two front fog lamps and fourth sample D of two front fog lamps, selected from stock manufactured after alignment, is necessary within two months time after the notification.

3.1. The conformity is not contested

3.1.1. Following the sampling procedure shown in Figure 1 of this annex the conformity of mass-produced front fog lamps shall not be contested if the deviations of the measured values of the front fog lamps are:

3.1.1.1. sample C

- C1: one front fog lamp.....0 %
- one front fog lamp not more than.....20 %
- C2: both front fog lamps more than.....0 %
- but not more than.....20 %

go to sample D

3.1.1.2. sample D

D1: in the case of C2

- both front fog lamps.....0 %

3.2. The conformity is contested

3.2.1. Following the sampling procedure shown in Figure 1 of this annex the conformity of mass-produced front fog lamps shall be contested and the manufacturer requested to make his production meet the requirements (alignment) if the deviations of the measured values of the front fog lamps are:

Sample D

D2: in the case of C2

- one front fog lamp more than.....0 %
- but not more than.....20 %
- one front fog lamp not more than20 %

3.3. Approval withdrawn

Conformity shall be contested and paragraph 12 applied if, following the sampling procedure in Figure 1 of this annex, the deviations of the measured values of the front fog lamps are:

- 3.3.1. sample C
- C3: one front fog lamp not more than.....20 %
one front fog lamp more than.....20 %
- C4: both front fog lamps more than.....20 %
- 3.3.2. sample D
- D3: in the case of C2
- one front fog lamp 0 or more than.....0 %
one front fog lamp more than.....20 %

4. CHANGE OF THE VERTICAL POSITION OF THE CUT-OFF LINE

With respect to the verification of the change in vertical positions of the cut-off line under the influence of heat, the following procedure shall be applied:

One of the front fog lamps of sample A after sampling procedure in Figure 1 of this annex shall be tested according to the procedure described in paragraph 2.1. of annex 4 after being subjected three consecutive times to the cycle described in paragraph 2.2.2. of annex 4.

The front fog lamp shall be considered as acceptable if D_r does not exceed 3.0 mrad.

If this value exceeds 3.0 mrad but is not more than 4.0 mrad, the second front fog lamp of sample A shall be subjected to the test after which the mean of the absolute values recorded in both samples shall not exceed 3.0 mrad.

However, if this value of 3.0 mrad on sample A is not complied with, the two front fog lamps of sample B shall be subjected to the same procedure and the value of D_r for each of them shall not exceed 3.0 mrad.

Figure 1

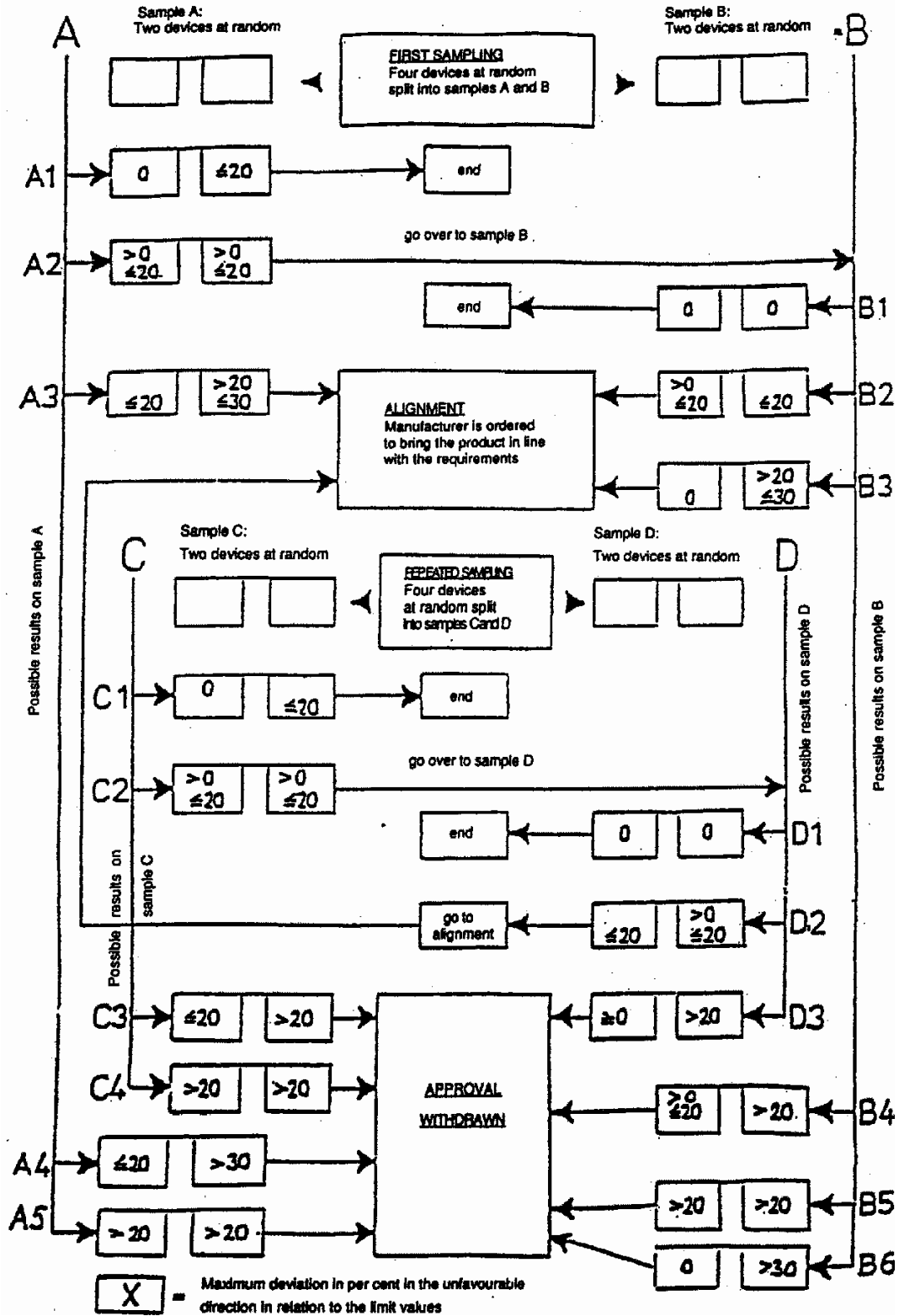

**UNITED
NATIONS**

E



**Economic and Social
Council**

Distr.

GENERAL

TRANS/WP.29/617
15 May 1998

ENGLISH

Original: ENGLISH
and FRENCH

ECONOMIC COMMISSION FOR EUROPE
INLAND TRANSPORT COMMITTEE
Working Party on the Construction of Vehicles

**DRAFT SUPPLEMENT 8 TO THE 02 SERIES OF AMENDMENTS TO
REGULATION No. 19 (Front fog lamps)**

Note: The text reproduced below was adopted by the Administrative Committee (AC.1) of the amended 1958 Agreement at its eighth session, following the recommendation by the Working Party at its one-hundred-and-fourteenth session. It is based on document TRANS/WP. 29/1998/16, not amended (TRANS / WP. 29/609, paras. 63 and 114).

Paragraph 2.2.1., amend to read:

"... specified; it shall be H₁, H₂, H₃, H₄, H₇, H₈, HB₃, HB₄, H27W/1, H27W/2, H₁₀ or H₁₁ filament lamp(s) as specified in Regulation No. 37;"

Paragraph 6.3., insert a new line to the existing table to read:

"H11 12 1000"

Annex 1, item 2, amend to read:

"2. ..Front fog lamp using a filament lamp category H₁, H₂, H₃, H₄, H₇, H₈, HB₃, HB₄, H27W/1, H27W/2, H₁₀, H₁₁^{2/}..... "

^{2/} (note not modified)

**UNITED
NATIONS**

E



**Economic and Social
Council**

Distr.

GENERAL

TRANS/WP.29/646
16 February 1999

ENGLISH

Original: ENGLISH
and FRENCH

ECONOMIC COMMISSION FOR EUROPE

INLAND TRANSPORT COMMITTEE

Working Party on the Construction of Vehicles

**DRAFT SUPPLEMENT 9 TO THE 02 SERIES OF AMENDMENTS TO
REGULATION No. 19 (Front fog lamps)**

Note: The text reproduced below was adopted by the Administrative Committee (AC. 1) of the amended 1958 Agreement at its tenth session following the recommendation by the Working Party at its one-hundred-and- sixteenth session. It is based on document TRANS/WP.29/1998/54, not amended (TRANS/WP.29/640, para. 155).

Paragraph 2.2.1., amend to read:

"... specified; it shall be H₁, H₂, H₃, H₄, H₇, H₈, HB₃, HB₄, H27W/1, H27W/2, H₁₀, H₁₁ or H₁₂ filament lamp(s) as specified in Regulation No. 37;"

Paragraph 6.3., insert a new line to the existing table to read:

"H12 12 775"

Annex 1, item 2, amend to read:

"2. ..Front fog lamp using a filament lamp category H₁, H₂, H₃, H₄, H₇, H₈, HB₃, HB₄, H27W/1, H27W/2, H₁₀, H₁₁, H₁₂^{2/} "

^{2/}(note not modified)