



## **Vehicle Standard (Australian Design Rule 4/01 – Seatbelts) 2006**

I, JAMES ERIC LLOYD, Minister for Local Government, Territories and Roads,  
determine this vehicle standard under subsection 7 (1) of the *Motor Vehicle Standards  
Act 1989*.

Dated            31 July 2006

[SIGNED]

James Eric Lloyd

Minister for Local Government, Territories and Roads

**CONTENTS**

0.	LEGISLATIVE PROVISIONS.....	3
A.	FUNCTION AND SCOPE.....	3
B.	APPLICABILITY .....	3
C.	APPLICABILITY TABLE .....	4
4.1.	DEFINITIONS .....	5
4.2.	REQUIREMENTS .....	6
4.3.	ADJUSTMENT REQUIREMENTS .....	9
4.4.	BUCKLE REQUIREMENTS .....	10
4.5.	GENERAL REQUIREMENTS FOR SEATBELT COMPONENTS.....	12
4.6.	RETRACTORS (OTHER THAN ‘ <i>TYPE 4N RETRACTORS</i> ’, FOR WHICH SEE APPENDIX A).....	13
4.7.	DYNAMIC TEST REQUIREMENTS .....	16
4.8.	RETRACTOR DURABILITY TEST .....	16
4.9.	DYNAMIC TESTING PROCEDURE .....	17
4.10.	TEST DUMMY REQUIREMENTS.....	17
4.11.	DUMMY CALIBRATION .....	17
4.12.	TEST RIG CALIBRATION .....	18
4.13.	COMPONENT BOUNDARY LOCATION .....	18
4.14.	DETAILED REQUIREMENTS FOR VEHICLE CATEGORIES MD3, MD4, ME, NB2 AND NC ONLY .....	19
4.15.	CORROSION CONDITIONING PROCEDURE FOR SEATBELT ASSEMBLIES FITTED IN ACCORDANCE WITH CLAUSE 4.14 .....	19
4.16.	ADJUSTMENT REQUIREMENTS FOR VEHICLE CATEGORIES MD3, MD4, ME, NB2 AND NC ONLY .....	20
4.17.	ALTERNATIVE STANDARDS .....	20
	APPENDIX A .....	23

**0. LEGISLATIVE PROVISIONS****0.1. NAME OF STANDARD**

0.1.1. This Standard is the Vehicle Standard (Australian Design Rule 4/01 – Seatbelts) 2006.

0.1.2. This Standard may also be cited as Australian Design Rule 4/01 — Seatbelts.

**0.2. COMMENCEMENT**

0.2.1. This Standard commences on the day after it is registered.

**0.3. REPEAL**

0.3.1. This Standard repeals each vehicle standard with the name Australian Design Rule 4/01 — Seatbelts that is:

(a) made under section 7 of the Motor Vehicle Standards Act 1989; and

(b) in force at the commencement of this Standard.

0.3.2. This Standard also repeals each instrument made under section 7 of the Motor Vehicle Standards Act 1989 that creates a vehicle standard with the name Australian Design Rule 4/01 — Seatbelts, if there are no other vehicle standards created by that instrument, or amendments to vehicle standards made by that instrument, that are still in force at the commencement of this Standard.

**A. FUNCTION AND SCOPE**

The function of this Australian Design Rule is to specify requirements for seatbelts to restrain vehicle occupants under impact conditions, to facilitate fastening and correct adjustment, to assist the driver to remain in his ‘Seat’ and thus maintain control of the vehicle in an emergency situation, and to provide protection against ejection in an accident situation.

**B. APPLICABILITY**

B.1. Subject to clause B.2, this ADR applies to the design and construction of vehicles as set out in the table below.

B.2. Where ECE 16/04 was used as the Alternative Standard, vehicles meeting the requirements of any of the Acceptable Prior Rules shown below in the Applicability Table for a particular category are deemed to comply with this rule.

B.3. For omnibuses complying with ADR 68/... only the driver’s seatbelt is required to comply with clauses 4.14 to 4.16 of this rule.

### C. APPLICABILITY TABLE

Vehicle Category	ADR Category Code *	UNECE Category Code *	Manufactured on or After	Acceptable Prior Rules
Moped 2 wheels	LA	L1	Not Applicable	
Moped 3 wheels	LB	L2	Not Applicable	
Motor cycle	LC	L3	Not Applicable	
Motor cycle and sidecar	LD	L4	Not Applicable	
Motor tricycle	LE	L5		
	LEM		Not Applicable	
	LEP		1 March 1991	Nil
	LEG		1 July 1992	Nil
Passenger car	MA	M1	1 Jan 1991	/00
Forward-control passenger vehicle	MB	M1	1 Jan 1991	/00
Off-road passenger vehicle	MC	M1	1 Jan 1991	/00
Light omnibus	MD	M2		
up to 3.5 tonnes 'GVM' and up to 12 seats	MD1		1 July 1991	/00
up to 3.5 tonnes 'GVM' and more than 12 seats	MD2		1 July 1992	Nil
over 3.5 tonnes and up to 4.5 tonnes 'GVM'	MD3		1 July 1992	Nil
over 4.5 tonnes and up to 5 tonnes 'GVM'	MD4		1 July 1992	Nil
Heavy omnibus	ME	M3	1 July 1992	Nil
Light goods vehicle	NA	N1	1 July 1991	/00
Medium goods vehicle	NB	N2		
over 3.5 tonnes up to 4.5 tonnes 'GVM'	NB1		1 July 1991	/00
over 4.5 tonnes up to 12 tonnes 'GVM'	NB2		1 July 1992	Nil
Heavy goods vehicle	NC	N3	1 July 1992	Nil
Very light trailer	TA	O1	Not Applicable	
Light trailer	TB	O2	Not Applicable	
Medium trailer	TC	O3	Not Applicable	
Heavy trailer	TD	O4	Not Applicable	

\* The category code may also be in the format L<sub>1</sub>, L<sub>A</sub> etc.

## 4.1. DEFINITIONS

- 4.1.1. 'Accessible' - a point on a seatbelt component is considered to be 'Accessible' if (Figure 2 refers) either:
- 4.1.1.1. it is located above Line J; or
- 4.1.1.2. it is capable of being enclosed by a straight 100 mm external diameter tube, a point of which extends to Line J and the centre line of which can intersect Line G at a point not more than 100 mm forward nor more than 300 mm rearward of Point O.
- 4.1.2. 'Automatic Length Adjusting and Locking Retractor' - a retractor incorporating a self actuating mechanism which automatically locks the retractor at the webbing extension selected by the user.
- 4.1.3. 'Buckle Component' - each one of the 2 parts of the buckle assembly designed to be latched to each other to complete the buckle assembly.
- 4.1.4. 'Correctly Fitted' - the design configuration of the 'Seatbelt Assembly' as installed in the vehicle using the 'Anchorages' and 'Sash Guide' devices, and adjusted around the occupant of the seating position to eliminate slack, with the occupant seated such that his centreline lies in the 'Seating Reference Plane' of the seating position.
- 4.1.5. 'Dry Breaking Strength' - the tensile strength of a webbing strap conditioned in an atmosphere at  $20 \pm 5^{\circ}\text{C}$  and relative humidity not more than 67%.
- 4.1.6. 'Emergency Locking Retractor' - a retractor incorporating a locking mechanism that is designed to lock under abnormal operating conditions.
- 4.1.7. 'Functional Component' - a component essential to the satisfactory operation of the 'Seatbelt Assembly' and without which the 'Seatbelt Assembly' would no longer meet the requirements of this rule.
- 4.1.8. 'Lap Sash Point' - the point representing the intersection of the lap and torso 'Straps' of a 'Lap-Sash Belt'.
- 4.1.9. 'Line X', 'Point Y' - a line or point of a family, established in clause 4.13 and represented in Figure 2, where X and Y represent a symbol listed in clause 4.13.
- 4.1.10. 'Manual Adjusting Device' - a device other than a retractor designed to be operated by the wearer to adjust the length of a 'Strap' of a 'Seatbelt Assembly'.
- 4.1.11. 'Seating Reference Locus' - the locus of a point fixed relative to the 'Seat', which is coincident with the 'Seating Reference Point' when the 'Seat' back is at the design 'Seat Back Angle' and when the 'Seat' is in the rearmost driving or riding position, as the 'Seat' traverses over the riding or driving range of 'Seat' travel.
- 4.1.12. 'Test Seat Datum Point' - a point in relation to the 'Seat' described in Figure 1 of clause 4.11.1. When viewed in side elevation it is located 120 mm above and 115 mm 'Forward' of the intersection of the planes of the 'Seat' base and the 'Seat' back.

- 4.1.13. *'Type 4N Retractor'* - an *'Emergency Locking Retractor'* which has a higher response threshold - i.e. having special properties as regard its use in vehicles other than passenger cars. Its properties are specified in Appendix A.
- 4.1.14. *'5th Percentile Adult Female'* - a dummy whose dimensions comply with the appropriate dimensions in Table 1, or a person with dimensions which are less than the appropriate dimensions in Table 1.
- 4.1.15. *'50th Percentile 6 Years Old Child'* - a dummy whose dimensions comply with the appropriate dimensions in Table 1, or a person with dimensions which are less than the appropriate dimensions in Table 1.
- 4.1.16. *'95th Percentile Adult Male'* - a dummy whose dimensions comply with the appropriate dimensions in Table 1, or a person with dimensions which are greater than the appropriate dimensions in Table 1.

## **4.2. REQUIREMENTS**

### **4.2.0. General**

- 4.2.0.1. Vehicle categories LEP, MA; MB; and MD1 shall comply with clauses 4.2.1 to 4.13.
- 4.2.0.2. Vehicle categories LEG, MC, MD2, NA and NB1 shall comply with either:
- 4.2.0.2.1. Clauses 4.2.1, 4.2.2.1 (excluding 4.2.2.1.3 and 4.2.2.1.4) and 4.2.3 to 4.13 (excluding 4.7.2 and 4.7.3, for omnibuses); or
- 4.2.0.2.2. Clause 4.2.0.1.
- 4.2.0.3. Vehicles categories MD3, MD4, ME, NB2 and NC shall comply with either:
- 4.2.0.3.1. clauses 4.2.1, 4.2.2.1 (excluding 4.2.2.1.3 and 4.2.2.1.4), 4.2.2.2, 4.2.2.3 and 4.14 to 4.16; or
- 4.2.0.3.2. Clause 4.2.0.1.; or
- 4.2.0.3.3. Clause 4.2.0.2 (except that clauses 4.2.2.2 and 4.2.2.3 shall be complied with).
- 4.2.1. *'Seatbelts Assemblies'* of a type determined by the *'Anchorage'* system shall be fitted to each seating position for which seatbelt *'Anchorages'* are required in accordance with ADR 5/... "Anchorages for Seatbelts and Child Restraints".
- 4.2.1.1. Threaded steel bolts of 7/16 inch - 20 UNF - 2A are recommended for attachment to the vehicle.
- 4.2.2. Type of *'Seatbelt Assembly'*
- 4.2.2.0. Not Used
- 4.2.2.1. A *'Lap-Sash Belt'* or *'Harness Belt'* shall:
- 4.2.2.1.1. when fitted to the driver's seating position incorporate an *'Emergency Locking Retractor'*.

- 
- 4.2.2.1.1.1. Where the driver's *'Seat'* is a *'Suspension Seat'* and not all the *'Anchorages'* are mounted on the moving part of the *'Seat'*, the retractor shall be a *'Type 4N Retractor'*.
- 4.2.2.1.2. when fitted to the other front *'Outboard Seating Position'*, incorporate an *'Emergency Locking Retractor'* or an *'Automatic Length Adjusting and Locking Retractor'*;
- 4.2.2.1.3. when fitted to any *'Outboard Seating Position'* of a *'Second Row Seat'* incorporate an *'Emergency Locking Retractor'* or an *'Automatic Length Adjusting and Locking Retractor'*; and
- 4.2.2.1.4. when fitted to any *'Outboard Seating Position'* other than the driver's seating position in a forward-control passenger vehicle (MB); or an omnibus (MD1) incorporate an *'Emergency Locking Retractor'* or an *'Automatic Length Adjusting and Locking Retractor'*.
- 4.2.2.2. For an ME or NC vehicle, a *'Lap Belt'* shall incorporate an *'Emergency Locking Retractor'* when fitted to the driver's seating position.
- 4.2.2.3. For an ME or NC vehicle, a *'Lap Belt'* shall, incorporate either an *'Emergency Locking Retractor'* or an *'Automatic Length Adjusting and Locking Retractor'* when fitted to the other front *'Outboard Seating Position'*.
- 4.2.3. Removal of the *'Seatbelt Assembly'* from the vehicle or separation of any *'Functional Components'* shall not be possible without the use of tools except in the case of:
- 4.2.3.1. the unlatching of the *'Buckle Components'*;
- 4.2.3.2. a *'Sash Guide'* device which is both:
- 4.2.3.2.1. designed to separate from its supporting structure or fail to retain the strap upon application of the *'Anchorage'* test loads ADR 5/... "Anchorages for Seatbelts and Child Restraints"; and
- 4.2.3.2.2. for which more than one point of attachment to the vehicle is available to provide the occupant with a choice of sash *'Strap'* positions relative to his shoulder; or
- 4.2.3.3. the torso *'Strap'* of a *'Lap-Sash Belt'* *'Seatbelt Assembly'* fitted to an *'Outboard Seating Position'* where the seat is designed to provide adjustment for conversion of occupant space to luggage or goods space and such seating position is not the driver's or front *'Seat'* passenger's seating position or the seating position immediately to the rear thereof.
- 4.2.3.4. The provisions of clause 4.2.3.3 above shall apply notwithstanding the requirements of clause 5 of AS 2596-1983 "Seat Belt Assemblies for Motor Vehicles".
- 4.2.4. In the case where a *'Lap-Sash Belt'* *'Seatbelt Assembly'* is provided with a torso *'Strap'* designed to be removed or separated from the *'Seatbelt Assembly'* in accordance with the provisions of clause 4.2.3 the requirements of this rule shall apply to the *'Seatbelt Assembly'* as:
- 4.2.4.1. a *'Lap-Sash Belt'* with the torso *'Strap'* operative; or
- 4.2.4.2. a *'Lap Belt'* with the sash *'Strap'* so removed or separated.
-

- 4.2.5. Any single component of the ‘*Seatbelt Assembly*’ having a mass in excess of 75 g other than a ‘*Strap*’, ‘*Anchor Fitting*’ or ‘*Sash Guide*’ device shall be located in areas other than that area forward of the ‘*Torso Reference Line*’ and between Line A and Line B when the assembly is correctly fitted for a ‘*95th Percentile Adult Male*’ and ‘*50th Percentile 6 Years Old Child*’ independently.
- 4.2.6. Each ‘*Seatbelt Assembly*’ shall be permanently and legibly marked with at least the manufacturer’s name or trade mark, date of manufacture by month and year, and identification code. The identification code shall be a number and/or symbol which uniquely identifies the ‘*Seatbelt Assembly*’ or sub-assembly design.
- 4.2.6.1. The same identification code may be used on two or more assembly or sub-assembly designs which are identical except for variations in ‘*Strap*’ length which do not exceed:
- 4.2.6.1.1. 25 mm in the case of a ‘*Strap*’ which has a length critical to the correct location of the ‘*Lap-Sash Point*’; or
- 4.2.6.1.2. 100 mm in the case of other ‘*Straps*’.
- 4.2.6.2. Furthermore, where a manufacturer, for “in-service” replacement purposes, provides for replacement of parts of a ‘*Seatbelt Assembly*’ rather than the assembly as a whole, each of the 2 sub-assemblies of the ‘*Seatbelt Assembly*’ which can be separated from each other by the normal unlatching process shall be permanently and legibly marked in accordance with the requirements of this clause.
- 4.2.7. ‘*Seatbelt Assemblies*’ shall comply with either:
- 4.2.7.1. The AS 2596 referred to in clause 4.2.3.4 but excluding clauses 1,2,4,15,16,17,18 and AS 2597.13 - 1983: “Determination of Dynamic Performance”;
- 4.2.7.1.1. the maximum dummy displacement limit in AS 2596-1983 section 14.1 (c), does not apply to ‘*Seatbelt Assemblies*’ required to comply with ADR 69/...
- 4.2.7.1.2. ‘*Seatbelt Assemblies*’ required to comply with ADR 69/... need not comply with the elongation and Hysteresis requirements specified in section 6.5 of AS 1753 - 1990; or
- 4.2.7.2. not used.
- 4.2.7.3. any other ‘*Approved*’ standard accepted as equivalent.
- 4.2.8. Instructions for use of ‘*Seatbelt Assemblies*’ shall be included in the vehicle handbook, or otherwise supplied with the vehicle. The instructions shall include the following text:
- 4.2.8.1. “WARNING: Seatbelts are designed to bear upon the bony structure of the body, and should be worn low across the front of the pelvis or the pelvis, chest and shoulders, as applicable; wearing the lap section of the belt across the abdominal area must be avoided.



“Seatbelts should be adjusted as firmly as possible, consistent with comfort, to provide the protection for which they have been designed. A slack belt will greatly reduce the protection afforded to the wearer.

“Care should be taken to avoid contamination of the webbing with polishes, oils and chemicals, and particularly battery acid. Cleaning may safely be carried out using mild soap and water. The belt should be replaced if webbing becomes frayed, contaminated or damaged.

“It is essential to replace the entire assembly after it has been worn in a severe impact even if damage to the assembly is not obvious.

“Belts should not be worn with straps twisted.

“Each belt assembly must only be used by one occupant; it is dangerous to put a belt around a child being carried on the occupant’s lap.”

- 4.2.8.2. In the case where a ‘Seatbelt Assembly’ incorporates an ‘Automatic Length Adjusting and Locking Retractor’ or an ‘Emergency Locking Retractor’:
- 4.2.8.2.1. “WARNING: No modifications or additions should be made by the user which will either prevent the seat belt adjusting devices from operating to remove slack, or prevent the seat belt assembly from being adjusted to remove slack.”; plus
- 4.2.8.2.2. a description of the adjustments necessary to ensure that the lap and sash portions of the ‘*Seatbelt Assembly*’ fit as firmly as possible consistent with comfort; and
- 4.2.8.2.3. instructions on the correct use of any device or devices included in the ‘*Seatbelt Assembly*’ which, upon manual or automatic operation, prevent the belt from being retracted.
- 4.2.9. When installed the ‘*Seatbelt Assembly*’ webbing shall not contact any sharp edges which could abrade or cut the webbing during normal use or in an accident. If necessary, the webbing shall be protected.

### **4.3. ADJUSTMENT REQUIREMENTS**

- 4.3.1. Each ‘*Seatbelt Assembly*’ shall be so designed that, with the adjustment provided, it shall be capable of being ‘*Correctly Fitted*’ for:
- 4.3.1.1. in the case of the driver’s seating position, a ‘*5th Percentile Adult Female*’ with the seat in the rearmost driving position and a ‘*95th Percentile Adult Male*’ with the ‘*Seat*’ in the foremost driving position; and
- 4.3.1.2. if installed at any other seating position, a ‘*50th Percentile 6 Years Old Child*’ with the ‘*Seat*’ in the rearmost riding position and a ‘*95th Percentile Adult Male*’ with the ‘*Seat*’ in the foremost riding position.
- 4.3.1.3. Furthermore, in the case of the fittings to the ‘*95th Percentile Adult Male*’ in 4.3.1.1 and 4.3.1.2 above, the design shall provide for at least 75 mm of additional ‘*Strap*’ in a ‘*Lap Belt*’ and at least 75 mm of additional ‘*Strap*’ in both the lap ‘*Strap*’ and upper torso ‘*Strap*’ of a ‘*Lap-Sash Belt*’ or ‘*Harness Belt*’. The purpose of this clause is to accommodate a

stouter person than represented by the 95th percentile anthropometric dimensions.

4.3.2. In the case of a *'Seatbelt Assembly'* incorporating a manual adjusting device, the following requirements shall be met when the assembly is correctly fitted for a *'95th Percentile Adult Male'* and a *'50th Percentile 6 Years Old Child'* independently, when the *'Seat'* is in the foremost riding or driving position (Figure 2 refers):

4.3.2.1. for tightening, the adjustment shall be by a single action at an *'Accessible'* point which lies between Line C and Line E and *'Forward'* of Line FOS; and

4.3.2.2. for loosening, the entire adjusting device shall lie between Line C and Line D and *'Forward'* to Line KPS and there shall be one point on the device which is *'Accessible'*.

4.3.2.3. For the purpose of determining whether the point is *'Accessible'*, the dummy or occupant may be removed.

4.3.3. Any free end of a *'Strap'* shall:

4.3.3.1. be designed so as to prevent it from passing through the adjuster under normal adjustment operations, and with the strap fully extended the *'Strap'*/adjuster combination shall be capable of withstanding, for not less than 30 seconds a static tensile load of 9 kN applied to the load bearing end of *'Strap'* with the adjuster restrained as in the vehicle; and

4.3.3.2. be restrained by a positive design feature to adopt a position against another *'Strap'*.

The free end of a *'Strap'* on any seat belt for a centre seating position or for an *'Outboard Seating Position'* not adjacent to a vehicle door need not meet this requirement.

4.3.3.3. Further, with the *'Strap'* fully extended, there shall be not less than 25 mm of material extending from the device to provide a grip for adjustment purposes. The material may either be attached to or form part of the free end of the *'Strap.'*

#### **4.4. BUCKLE REQUIREMENTS**

4.4.1. It shall not be possible to adjust a *'Lap-Sash Belt'* so that when correctly fitted for a *'5th Percentile Adult Female'*, the *'Lap Sash Point'* is less than 125 mm in the case of *'Seats'* with *'Forward'* and *'Rearward'* adjustment, or 175 mm in the case of fixed *'Seats'*, from the *'Seating Reference Plane'* when measured along the centreline of the pelvic restraint section of the belt. This requirement shall be met with the *'Seat'* in its foremost and rearmost driving or riding position and with the *'Seat'* back at the design *'Seat Back Angle'*.

4.4.2. In cases where the *'Buckle Component'* of a *'Lap-Sash Belt'* *'Strap'* can be latched with part of an assembly intended for an adjacent seating position, the design shall be such that the requirements of clause 4.4.1 are met irrespective of the combination used.

- 4.4.3. In cases where the *'Buckle Component'* of a *'Seatbelt Assembly'* can be engaged either wholly or partially with the *'Buckle Component'* of a *'Seatbelt Assembly'* intended for an adjacent seating position, the design shall be such that the *'Seatbelt Assembly'* so formed shall comply with the requirements of clause 14 of the AS 2596 - 1983 "Seat Belt Assemblies for Motor Vehicles".
- 4.4.3.1. This requirement shall apply irrespective of whether the wholly or partially engaged components will separate without operation of the unlatching device.
- 4.4.3.2. This requirement shall not apply in cases where *'Seatbelt Assemblies'* fitted to adjacent seating positions are from the same manufacturer and have the same buckle design.
- 4.4.4. In the case of a *'Lap-Sash Belt'* incorporating a retractor, the design shall be such that in the fully retracted position, the *'Buckle Component'* associated with the retracting *'Strap'* must adopt a position that is either:
- 4.4.4.1. *'Accessible'*; and
- 4.4.4.1.1. within 300 mm of both foremost and rearmost points on the *'Seating Reference Locus'* when viewed in side elevation or within 300 mm of Point O and Point N when viewed in side elevation; and
- 4.4.4.1.2. within 400 mm of the *'Seating Reference Plane'* when viewed in plan; or
- 4.4.4.2. can be moved to a position which meets the requirements of clauses 4.4.4.1.0 to 4.4.4.1.2 above by a manual operation applied to the assembly at points which meet the requirements of clauses 4.4.4.1.0 to 4.4.4.1.2.
- 4.4.4.3. This requirement shall not apply to a seating position adjacent to an access door, where the *'Seat'* must hinge or fold to permit access to another seating position.
- 4.4.5. In the case of a vehicle with one front seating position only, or with 2 front *'Seats'* each providing for one seating position only, the *'Buckle Component'* on that part of a *'Lap-Sash Belt'* which does not include the retracting *'Strap'* shall be supported by a rigid member which may pivot, or in such a manner that after being correctly fitted for a *'95th Percentile Adult Male'* with the *'Seat'* in the foremost driving or riding position, unlatching of the buckle assembly and removal of the occupant from the seating position does not result in any point on the component moving downwards such that the vertical component of movement is more than 50 mm.
- 4.4.5.1. When unlatched after the assembly has been correctly fitted for a *'95th Percentile Adult Male'* with the *'Seat'* in the foremost driving or riding position and a *'5th Percentile Adult Female'* with the *'Seat'* in the rearmost driving or riding position, independently, there shall be a point on the component which is:
- 4.4.5.1.1. *'Accessible'*;
- 4.4.5.1.2. within 300 mm of both the foremost and rearmost points on the *'Seating Reference Locus'* when viewed in side elevation; and

- 4.4.5.1.3. within 150 mm to 400 mm of the 'Seating Reference Plane' when viewed in plan.
- 4.4.5.2. For the purpose of determining whether the point is 'Accessible', the dummy or occupant may be removed.
- 4.4.6. In the case of outboard seating positions not provided for in clause 4.4.5 the part of the assembly which does not include the 'Strap' designed to pass over the torso of the occupant shall be so restrained by a positive design feature that one point at least cannot pass 'Rearward' of the line of contact of the 'Seat' cushion with the 'Seat' back.
- 4.4.6.1. The line of contact of the 'Seat' cushion with the 'Seat' back is the front boundary of the area of contact across the 'Seat' width of the 'Seat' cushion with the 'Seat' back when the 'Seat' cushion is unoccupied.
- 4.4.6.2. The requirements of clause 4.4.6 shall be met when a folding or hinged 'Seat' is in its normal position. Re-establishment of such a 'Seat' may include a manual operation to re-establish part of the 'Seatbelt Assembly'.
- 4.4.7. In the case of 'Lap-Sash Belt' assemblies not incorporating 'Emergency Locking Retractors', or Automatic Length Adjusting and Locking Retractors' fitted to outboard seating positions vehicles.
- 4.4.7.1. The design shall provide for a stowage feature for the part of the assembly which includes the 'Strap' designed to pass over the pelvis or torso of the occupant, to facilitate that part of the assembly, when unlatched, being kept clear of the vehicle floor and the lower edge of the door opening.
- 4.4.8. The area of vehicle floor does not include areas which are inaccessible to the occupant's feet during travel or during entry and exit.

#### **4.5. GENERAL REQUIREMENTS FOR SEATBELT COMPONENTS**

- 4.5.1. In all cases where the 'Strap' passes through another component, other than a 'Sash Guide' used in conjunction with an 'Emergency Locking Retractor', and there is relative movement between the 'Strap' and the component as a result of adjusting operations, the tensile strength of the webbing shall not be reduced to less than 14.7 kN or 75% of the 'Dry Breaking Strength', whichever is the greater, after 2,500 cycles of relative movement under the following test conditions:
- 4.5.1.1. the tensile load in all parts of the test 'Strap' during the working stroke of the 2 strokes of each cycle shall be not less than 13 N;
- 4.5.1.2. the working stroke shall be not less than 150 mm nor more than 200 mm; and
- 4.5.1.3. the angle which the centreline of each end of the test 'Strap' makes with the component shall be not less critical to 'Strap' abrasion than that nominated by the vehicle 'Manufacturer' as representative of such angle of the 'Strap' in use, when the assembly is correctly fitted for a '5th Percentile Adult Female' with the 'Seat' in the rearmost driving or riding position, except that in the case where the design provides for the centrelines of the straps to be separated when viewed normal to the plane

of one 'Strap', then such angle of separation in the test may be any angle greater than 25°, and the angle of separation of the centrelines of the 'Straps' when viewed in the plane of one 'Strap' may be any angle less than 10°.

- 4.5.2. In the case of a 'Lap-Sash Belt' incorporating an 'Emergency Locking Retractor' (other than a 'Type 4N Retractor', for which see Appendix A). where, during the wearing and retracting operations, there is relative movement between the retracting 'Strap' and the 'Sash Guide' system other than the retractor itself the tensile strength of the webbing shall not be reduced to less than 14.7 kN or 75% of the 'Dry Breaking Strength', whichever is the greater, after the retracting 'Strap' has been drawn through the 'Sash Guide' system for 50,000 cycles under the following test conditions:
- 4.5.2.1. the tensile load in all parts of the test 'Strap' during the working stroke of the 2 strokes of each cycle shall not be less than 18 N;
- 4.5.2.2. the tensile load in the test 'Strap' at one point in the cycle shall be reduced to zero;
- 4.5.2.3. the working stroke shall be not less than 200 mm;
- 4.5.2.4. the orientation of the test 'Strap' relative to the 'Sash Guide' shall be such that:
- 4.5.2.4.1. the 'Sash Guide' shall be in its design configuration except that, for 'Sash Guides' designed to pivot, the angle of the axis of rotation may vary from its design configuration provided that such variation is not greater than 5°
- 4.5.2.4.2. the part of the test 'Strap' which simulates the 'Strap' passing from the 'Sash Guide' to the next 'Sash Guide' or to the retractor, shall be in the design configuration; and
- 4.5.2.4.3. the part of the test 'Strap' which simulates the torso 'Strap' shall be pulled in a vertical plane not more than 45° or a longitudinal plane when viewed in plan, and the direction of pull in that plane shall vary over a range of not less than 65° during the working stroke of each cycle; and
- 4.5.2.5. all 'Sash Guides' for the one assembly shall be tested simultaneously.
- 4.5.2.6. The requirements of this clause shall not apply to relative movement between the 'Strap' and the retractor, at the retractor.
- 4.5.3. Buckle-Spring Fatigue Resistance
- 4.5.3.1. In the case where a spring is incorporated in the unlatching mechanism of a buckle, the load required to operate the spring shall not be reduced by more than 20% after the spring has been subjected to 50,000 operations each involving a movement not less than 95% of the design movement for buckle unlatching.
- 4.6. RETRACTORS (OTHER THAN 'TYPE 4N RETRACTORS', FOR WHICH SEE APPENDIX A).**
- 4.6.1. All retractors incorporated in 'Seatbelt Assemblies' shall comply with the requirements of clause 4.6.2 and either clause 4.6.3 or 4.6.4.

#### 4.6.2. General Requirements for Retractors

- 4.6.2.1. After being subjected to the retractor durability test of clause 4.8, the retractor shall:
- 4.6.2.1.1. when locked, either:
- 4.6.2.1.1.1. withstand a tensile load of not less than 9 kN applied to the 'Strap'; or
- 4.6.2.1.1.2. be subjected to the strength of assembly test of clause 14.1 of AS 2596-1983 "Seatbelt Assemblies for Motor Vehicles".
- 4.6.2.1.2. withstand a tensile load of not less than 9 kN applied to the 'Strap'. For the purpose of this test the 'Strap' shall be fully withdrawn and the locking mechanism shall be rendered inoperative.
- 4.6.2.2. In cases where the retracting 'Strap' of a 'Lap-Sash Belt' is the torso 'Strap', the retraction force in the 'Strap' before and after the retractor has been subjected to the retractor durability test of clause 4.8, shall be not less than 2 N nor more than 10 N, under the following test conditions:
- 4.6.2.2.1. the 'Sash Guide' system and the retractor shall be in the design configuration. In the case of a 'Sash Guide' system with an adjustable 'Sash Guide' the retractor shall be capable of meeting the requirements of this clause with the 'Sash Location Point' set in any position of adjustment;
- 4.6.2.2.2. the part of the test 'Strap' which simulates the torso 'Strap' shall be withdrawn through the 'Sash Guide' system until it is within 430 mm of its fully extended condition;
- 4.6.2.2.3. the 'Strap' shall be allowed to retract until a point on the 'Strap' is  $450 \pm 20$  mm, measured along the 'Strap' from its position when the 'Strap' is fully extended. It shall then be held stationary at this extension by a force applied in a downward direction at  $20 \pm 10^\circ$  to the vertical in a vertical plane which is at  $35 \pm 10^\circ$  to a longitudinal plane when viewed in plan, and shall not be withdrawn again until the retracting force has been determined;
- 4.6.2.2.4. the retraction force shall be measured in the test 'Strap' 'Forward' of the point where it would contact the first 'Sash Guide' device after passing over the shoulder of the wearer; and
- 4.6.2.2.5. where the assembly incorporates a device that upon manual or automatic operation, prevents the belt from being completely retracted, such a device shall not be operating when this requirement is assessed.
- 4.6.3. *'Automatic Length Adjusting and Locking Retractors'*
- The locking mechanism of an 'Automatic Length Adjusting and Locking Retractor' shall be designed to provide a locked position for at least every 30 mm of 'Strap' extension from the position when the 'Seatbelt Assembly' is correctly fitted for a '50th Percentile 6 Years Old Child', with the 'Seat' in the rearmost riding position.

- 4.6.4. ***'Emergency Locking Retractors'* (other than *'Type 4N Retractors'*, for which see Appendix A).**
- 4.6.4.1. *'Emergency Locking Retractors'* shall lock when the retractor and any associated devices to sense acceleration are accelerated at not more than 5 m/s<sup>2</sup>, the peak acceleration being attained in not less than 40 milliseconds.
- 4.6.4.1.0. Furthermore with a point on the external *'Strap'* fixed the locking device shall limit *'Strap'* movement, measured from the time of application of the acceleration, to not more than:
- 4.6.4.1.0.1. 30 mm, when the *'Strap'* is withdrawn to a point which is 150 ± 5 mm from the fully extended position; and
- 4.6.4.1.0.2. 80 mm, when the *'Strap'* is withdrawn to points 450 ± 5 mm and 760 ± 5 mm from the fully extended position, if the *'Seatbelt Assembly'* includes sufficient *'Strap'* to attain these extensions.
- 4.6.4.1.1. This requirement shall be met under positive and negative acceleration in longitudinal, transverse and vertical directions, except that in cases where the device is designed to lock when tilted to any angle in excess of 45° then the locking requirement need be met for longitudinal and transverse directions only.
- 4.6.4.1.2. Sensing of acceleration to meet the requirements of this clause shall not be dependent upon rate of withdrawal of *'Strap'* from the retractor. In demonstrating this requirement, any device dependent for sensing of acceleration on withdrawal of *'Strap'* from the retractor may be rendered inoperative.
- 4.6.4.2. *'Emergency Locking Retractors'* shall be designed in such a way that when the *'Strap'* is extended at an acceleration of not more than 20 m/s<sup>2</sup> locking occurs within 25 mm of *'Strap'* extension. This requirement shall be met at an extrapolated point representing full extension based on test results achieved at points of extension which are less than the full extensions by 150 ± 5 mm, 450 ± 5 mm, and 750 ± 5 mm (if available), respectively.
- 4.6.4.3. An *'Emergency Locking Retractor'* shall be designed to lock automatically, or meet the requirements of clauses 4.6.4.1 and 4.6.4.2 upon any single mechanical failure of a spring which is part of the locking mechanism.
- 4.6.4.4. In cases where the operation of a retractor depends on an external signal or power source, the design shall ensure that the retractor locks automatically upon failure or interruption of that signal or power source.
- 4.6.4.5. The design of an *'Emergency Locking Retractor'* shall ensure that it remains unlocked when the vehicle is tilted up to 12°, longitudinally or transversely, from the horizontal.

#### **4.7. DYNAMIC TEST REQUIREMENTS**

- 4.7.1. *'Seatbelt Assemblies'* for front facing *'Seats'* shall not separate within themselves or from any *'Anchorage'*, when tested in accordance with the dynamic test procedure of clause 4.9.
- 4.7.2. Prior to the dynamic test, each *'Seatbelt Assembly'* shall be subjected to the preconditioning requirements of clause 4.7.3.
- 4.7.3. Dynamic Test Preconditioning
- 4.7.3.1. Any *'Buckle Component'* or manual adjusting device which can take up a position in a door opening, or under a pivoting *'Seat'*, shall be placed on a flat surface in its most stable position and subjected to a force of not less than 1.8 kN for a period of not less than 10 seconds. The force shall be applied through a rigid bar of diameter not more than 20 mm formed to an arc of radius not more than 150 mm, with the bar in line with the *'Strap'* when viewed in plan, and the test shall be repeated with the bar normal to the direction of the *'Strap'* when viewed in plan.
- 4.7.3.2. The buckle assembly shall be subjected to not less than 20,000 unlatching operations. During each unlatching operation a tensile load of not less than 20 N shall be applied to the assembly.
- 4.7.3.3. Each *'Seatbelt Assembly'* which contains non-metallic material (other than a webbing *'Strap'*) shall be exposed to environment over a water surface within a closed space, the environment having a temperature of not less than 80°C, for a continuous period of not less than 24 hours and then cooled in an environment having a temperature not exceeding 23°C. The cooling period shall immediately be followed by three consecutive 24 hour cycles with each cycle comprising the following consecutive sequences:
- 4.7.3.3.1. an environment having a temperature of not less than 100°C shall be maintained for a continuous period of 6 hours and this environment shall be attained within 80 minutes of commencement of the cycle; then
- 4.7.3.3.2. an environment having a temperature of not more than 0°C shall be maintained for a continuous period of 6 hours and this environment shall be attained within 20 minutes; then
- 4.7.3.3.3. an environment having a temperature of not more than 23°C shall be maintained during the remainder of the 24 hour cycle.

#### **4.8. RETRACTOR DURABILITY TEST**

- 4.8.0. The *'Seatbelt Assembly'* shall be prepared, conditioned and tested to AS 2597.9-1983 "Preparation and Conditioning of Test Specimens for Retractor Function".
- 4.8.1. Not used.
- 4.8.2. Not used.
- 4.8.3. Not used.



#### **4.9. DYNAMIC TESTING PROCEDURE**

- 4.9.1. The test rig shall have a mass of not less than 380 kg and shall meet the requirements of clause 4.12 for test rig calibration. It shall comprise either:
- 4.9.1.1. a trolley and 'Seat' as specified in clauses 4.11.1 and 4.11.2 for dummy calibration, and with 'Anchorages' and 'Sash Guide' devices within 100 mm of their design positions with the test seat datum point assumed to coincide with the 'Seating Reference Point'; or
- 4.9.1.2. a trolley and a vehicle body shell complete with a representative 'Seat' adjusted to the rearmost driving or riding position.
- 4.9.2. A dummy meeting the requirements of clause 4.10 shall be placed in the appropriate seating position so that its centre-line lies in the 'Seating Reference Plane' and such that it is restrained by the 'Seatbelt Assembly' as follows:
- 4.9.2.1. in the case of 'Seatbelt Assemblies' incorporating retractors, the belt shall be manually adjusted around the dummy to eliminate slack; and
- 4.9.2.2. in the case of other 'Seatbelt Assemblies', a spacer of flexible but substantially incompressible material not less than 25 mm thick and at least as wide and as long as the dummy's back shall be placed behind the back of the dummy. The assembly shall be adjusted to eliminate slack and the spacer then removed. The dummy shall be re-positioned so that its back is in contact with the 'Seat' back.
- 4.9.3. The rig shall be operated in a manner identical in all operational respects to that specified in clause 4.12.1 for rig calibration except that in this case the dummy replaces the inert mass.

#### **4.10. TEST DUMMY REQUIREMENTS**

- 4.10.1. The dummy shall have a mass of  $74 \pm 2$  kg.
- When tested in accordance with the requirements of clause 4.11 for dummy calibration, the test dummy shall give rise to 'Seatbelt Assembly' loads such that the sum of the peak restraining forces in each length of the sash 'Strap' which is not in contact with the dummy is not less than 10 kN, and also that the sum
- 4.10.2. of the peak restraining forces in each length of the lap 'Strap' which is not in contact with the dummy is not less than 10 kN.

#### **4.11. DUMMY CALIBRATION**

- 4.11.1. The test rig shall have a mass of not less than 380 kg and, shall meet the requirements of clause 4.12 for test rig calibration. It shall comprise a trolley, test 'Seat', foot rest, and structure for providing seatbelt 'Anchorages', meeting the dimensional requirements indicated in Figure 1.
- 4.11.2. The 'Seat' base surface shall not be designed with energy absorbing characteristics and shall present a smooth surface for the dummy.

- 4.11.3. The dummy shall be restrained by separate '*Lap Belts*' and sash belts, each of which comprises load bearing material having an elongation of not less than 12% when subjected to a load of 11 kN. The method of test of elongation shall be determined by the method described in AS 1753-1975: "Webbing for Restraining Devices for Occupants of Motor Vehicles", except that the specimen shall be loaded to 11 kN in lieu of the load specified in the Australian Standard.
- 4.11.4. The '*Lap Belts*' and sash belts shall be adjusted to eliminate slack.
- 4.11.5. The rig shall be operated in a manner identical in all operational respects to that specified in clause 4.12.2 for rig calibration except that in this case the dummy replaces the inert mass.

#### **4.12. TEST RIG CALIBRATION**

- 4.12.1. In the case of calibration prior to seat belt testing, the test rig, to which a mass of  $74 \pm 2$  kg is rigidly attached, when subjected to a velocity change of not less than 49 km/h, shall achieve within 30 milliseconds a '*Forward*' deceleration measured in the vicinity of a lap '*Anchorage*' of at least  $235 \text{ m/s}^2$  and shall maintain this deceleration, except for periods of less than one millisecond, for not less than 20 milliseconds.
- 4.12.2. In the case of calibration prior to proving the dummy, the test rig, to which a mass of  $74 \pm 2$  kg is rigidly attached, when subjected to a velocity change of not less than 49 km/h, shall achieve within 30 milliseconds, a '*Forward*' deceleration measured in the vicinity of a lap '*Anchorage*', within the range 235 to  $335 \text{ m/s}^2$  and shall maintain this deceleration, except for periods of less than one millisecond, for not less than 20 milliseconds.

#### **4.13. COMPONENT BOUNDARY LOCATION**

- 4.13.0. The lines shown in Figure 2 in side elevation are established as follows:
- 4.13.1. Line A is a horizontal line 850 mm above the '*Seating Reference Point*';
- 4.13.2. Line B is a horizontal line 330 mm above the '*Seating Reference Point*';
- 4.13.3. Line C is a horizontal line 680 mm above the '*Seating Reference Point*';
- 4.13.4. Line D is a horizontal line 150 mm below the '*Seating Reference Point*';
- 4.13.5. Line E is a horizontal line 75 mm below the '*Seating Reference Point*';
- 4.13.6. Line FOS consists of 2 lines FO and OS and is constructed as follows:
- 4.13.6.1. draw line FO parallel to the '*Torso Reference Line*' and intersecting Line G at Point O, such that the extension of Line FO passes through the most '*Forward*' point on the '*Seating Reference Locus*'; and
- 4.13.6.2. draw a vertical Line OS intersecting Line G at Point O;
- 4.13.7. Line KPS consists of 2 Lines KP and PS and is constructed as follows:
- 4.13.7.1. draw Line KP parallel to and 100 mm '*Rearward*' of Line FO (established above) intersecting Line OS at P; and
- 4.13.7.2. Line PS is coincident with Line OS,

4.13.8. Line G is a horizontal Line 380 mm above the '*Seating Reference Point*', intersecting the '*Torso Reference Line*' at Point N; and

4.13.9. Line J is a horizontal Line 230 mm above the '*Seating Reference Point*'.

#### **4.14. DETAILED REQUIREMENTS FOR VEHICLE CATEGORIES MD3, MD4, ME, NB2 AND NC ONLY**

4.14.1. Separation of any '*Functional Components*' of the '*Seatbelt Assembly*', other than unlatching of the '*Buckle Components*', shall not be possible without the use of tools.

4.14.2. '*Seatbelt Assemblies*' shall comply with either:

4.14.2.1. AS 2596-1983, as referenced in clause 4.2.7.1 but excluding clauses 1,2,4,15,16,17,18 and excluding dynamic testing to the AS 2597 referred to in clause 4.2.7.1 provided that the maximum test load shall not be less than 9 kN and the corrosion conditioning procedure shall be that specified in clause 4.15;

4.14.2.2. Not used.

4.14.2.3. Not used.

4.14.2.4. Federal Motor Vehicle Safety Standard No. 209, "Seat Belt Assemblies" current as at 13 December 1979 except that the use of non-locking retractors as defined in that Standard shall not be allowed;

4.14.2.5. ECE Regulation 16/04, "Safety Belts" (except that the use of a non-locking retractor as defined in that Regulation shall not be allowed); or

4.14.2.6. Any other '*Approved*' standard accepted as equivalent.

4.14.3. The operation of any '*Emergency Locking Retractor*' (including a '*Type 4N Retractor*') incorporated in a '*Seatbelt Assembly*' shall not be dependent solely upon rate of withdrawal of '*Strap*' from the retractor.

4.14.4. Not used

4.14.5. In the case of a non- '*Suspension Seat*' where the '*Seatbelt Assembly*' is not mounted on the '*Seat*' the '*Buckle Component*' which does not include the retracting '*Strap*' shall comply with the accessibility requirements of clause 4.4.5.1.

#### **4.15. CORROSION CONDITIONING PROCEDURE FOR SEATBELT ASSEMBLIES FITTED IN ACCORDANCE WITH CLAUSE 4.14**

4.15.1. The '*Seatbelt Assembly*' shall be conditioned by the procedure specified in the ASTM B117-64 "Standard Method of Salt Spray (Fog) Testing".

4.15.2. The period of conditioning shall be not less than 50 hours, and at the end of the conditioning procedure specified in clause 4.15.1 the '*Seatbelt Assembly*' may be washed thoroughly with water to remove the salt. If washed, the webbing shall be fully extended and allowed to dry for at least 24 hours in an atmosphere having a relative humidity of not less than 48% nor more than 67% and a temperature of not less than 21°C nor more than 25°C. The webbing shall then be withdrawn manually and allowed to retract for 25 cycles.

#### 4.16. ADJUSTMENT REQUIREMENTS FOR VEHICLE CATEGORIES MD3, MD4, ME, NB2 AND NC ONLY

- 4.16.1. With the 'Seatbelt Assembly' in the unlatched condition, a point on each separate portion of the seat belt shall be located by a design feature to adopt a position not more than 100 mm below the top edge of the seat cushion measured in the immediate vicinity of such a design feature.
- 4.16.2. Any free end of a 'Strap' shall be restrained by a design feature to adopt a position against another 'Strap'.
- 4.16.3. With the 'Strap' fully extended, there shall be not less than 25 mm of material extending from the adjusting device to provide a grip for adjustment purposes. The material may either be attached to or form part of the free end of the 'Strap'.

#### 4.17. ALTERNATIVE STANDARDS

- 4.17.1. The technical requirements of ECE R 16/04 "Safety Belts" shall be deemed to be equivalent to the technical requirements of this rule, provided that
- 4.17.1.1. for clauses 4.14 to 4.16 non-locking retractors shall not be employed;
- 4.17.1.2. the sunlight exposure requirement of the Australian Standards referred to in clause 4.2.7 and the dust and preconditioning (before any dynamic testing) requirements of this rule are met; and
- 4.17.1.3. the free end requirements of clauses 4.3.3.2 or 4.16.2 of this rule are met.

<b>TABLE 1</b>			
<b>DUMMY DIMENSIONS <sup>##</sup></b>			
	<i>'95th Percentile Adult Male'</i>	<i>'5th Percentile Adult Female'</i>	<i>'50th Percentile 6 Years Old Child'</i>
Mass	97.5 ± 5 kg	46 ± 5 kg	21.4 ± 3 kg
Erect sitting height	965 mm	785 mm	645 mm
Hip breadth (sitting)	415 mm	325 mm	215 mm
Hip circumference (sitting)	1200 mm	925 mm	605 mm
Waist circumference (sitting)	1080 mm	600 mm	530 mm
Chest Depth	265 mm	190 mm	160 mm
Chest circumference	1130 mm	775 mm (nipple) 755 mm (upper) 675 mm (lower)	595 mm
Shoulder height	680 mm	520 mm	415 mm
<sup>##</sup> Tolerance on all length dimensions ± 5 %			

**FIGURE 1  
TEST SEAT AND ANCHORAGES**

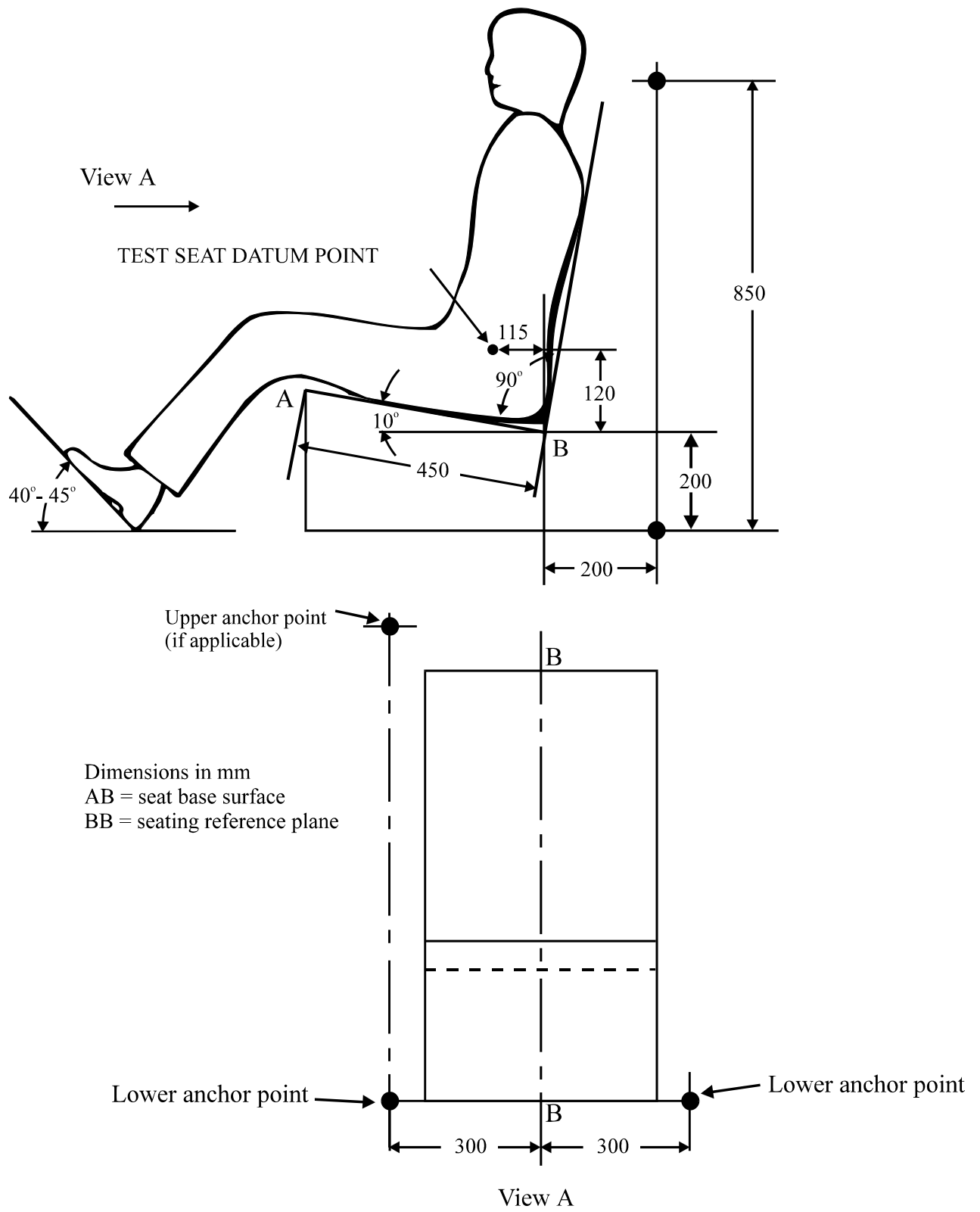

**FIGURE 2  
COMPONENT BOUNDARY LOCATION**

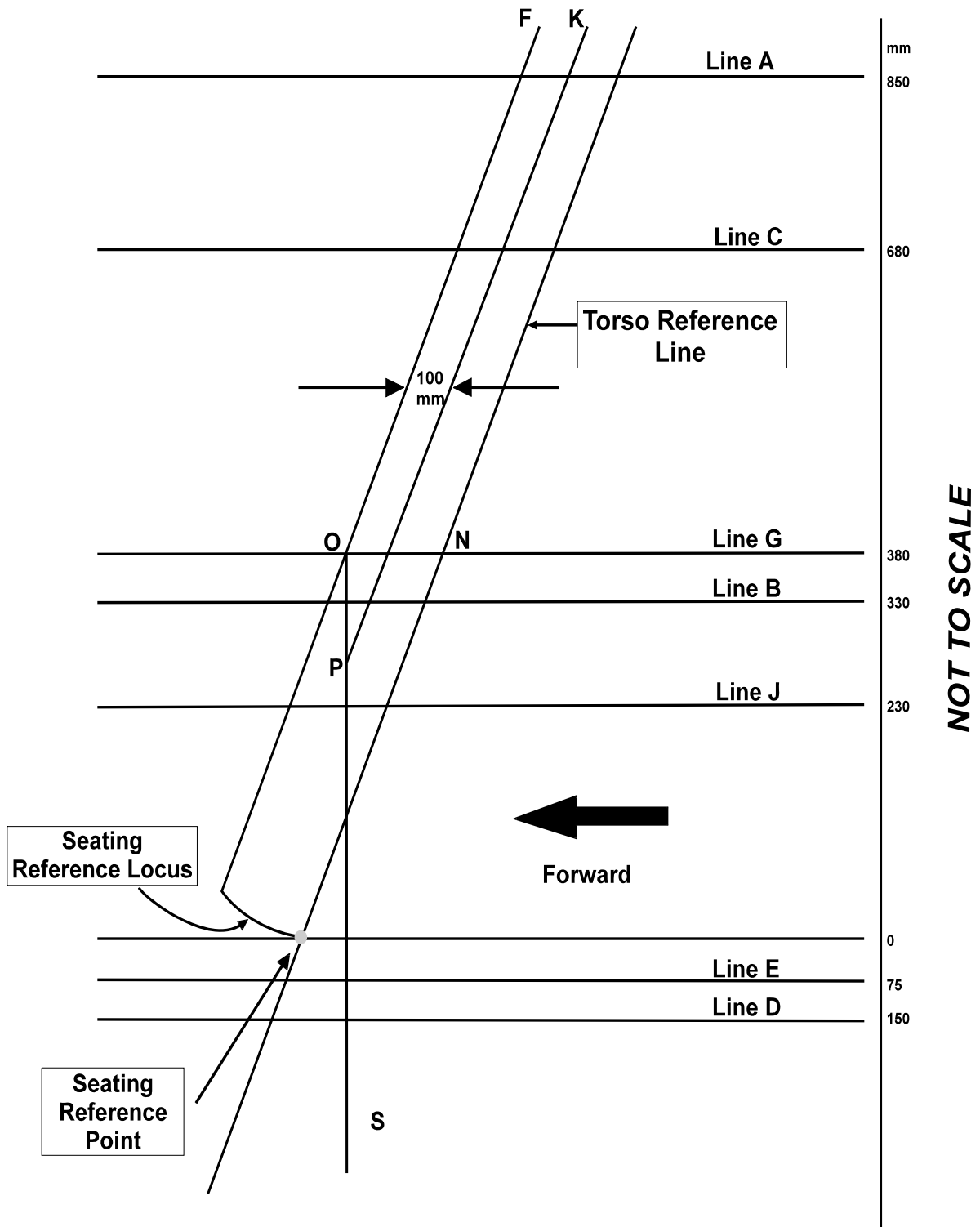

## APPENDIX A

### REQUIREMENTS FOR 'TYPE 4N RETRACTORS'

The following text is from ECE Regulation 16/04 "Safety Belts", with text not applicable in Australia struck through. The text has been modified slightly, to make it clear that it only applies to 'Type 4N Retractors'.

#### 6.2.5.3 ~~Emergency locking retractors~~ 'TYPE 4N RETRACTORS'

6.2.5.3.1 A ~~non-emergency locking~~ 'Type 4N Retractor', when tested in accordance with paragraph 7.6.2 shall satisfy the conditions below:

#### 4.4.7 IN ADDITION, IN AUSTRALIA FOR DYNAMIC TESTING, THE REQUIREMENTS OF SECTION 4.7 SHALL BE COMPLIED WITH.

6.2.5.3.1.1 The locking must have occurred when the deceleration of the vehicle reaches ~~0.45 in the case of type 4~~ and  $0.85\text{ g}^{11}$  in the case of 'Type 4N Retractors'.

6.2.5.3.1.2 It must not lock for values of acceleration of the strap measured in the direction of the extraction of the strap of less than ~~0.8 g in the case of type 4~~ or less than  $1.0\text{ g}^1$  in the case of 'Type 4N Retractors'.

6.2.5.3.1.3 It must not lock when its sensing device is tilted  $12^\circ$  or less in any direction from the installation position specified by its manufacturer.

6.2.5.3.1.4 It shall lock when its sensing device is tilted by more than  ~~$27^\circ$  in the case of type 4~~ or  $40^\circ$  in the case of 'Type 4N Retractors' in any direction from the installation position specified by its manufacturer.

6.2.5.3.1.5 In cases where the operation of a retractor depends on an external signal or power source, the design shall ensure that the retractor locks automatically upon failure or interruption of that signal or power source.

6.2.5.3.2 A retractor with multiple sensitivity must satisfy the specification above, when tested in accordance with paragraph 7.6.2. In addition if one of the sensitivities relates to strap extraction, locking must have occurred at a strap acceleration equal to or more than  ~~$1.5\text{ g}$  in the case of type 4~~ or more than  $2.0\text{ g}^1$  in the case of 'Type 4N Retractors', when measured along the line of the extraction of the strap.

6.2.5.3.3 In the case of the tests mentioned in paragraphs 6.2.5.3.1 and 6.2.5.3.2 above the amount of strap movement which may occur before the retractor locks shall not exceed 50 mm starting at the length given in paragraph 7.6.2.1. In the case of the test mentioned in paragraph 6.2.5.3.1.2 above locking must not occur during the 50mm of strap movement starting at the length given in paragraph 7.6.2.1.

6.2.5.3.4 If the retractor is part of a lap belt, the retracting force of the strap shall be not less than 0.7 daN when measured in the free length between the dummy and the retractor in accordance with paragraph 7.6.4. If the retractor is part of an upper torso restraint, the retracting force of the strap shall be not less than 0.2 daN and not more than 0.7 daN when similarly measured. If the strap passes through a guide or pulley, the retractor force shall be measured in the free length between the dummy and the guide or pulley. If the

<sup>1</sup>  $1\text{ g} = 9.81\text{ m/s}^2$

assembly incorporates a device that upon manual or automatic operation prevents the strap from being completely retracted, such a device shall not be operated when these requirements are assessed.

- 6.2.5.3.5** The strap shall be withdrawn from the retractor and allowed to retract repeatedly by the method described in paragraph 7.6.1 until 40,000 cycles have been completed. The retractor shall then be subjected to the corrosion test given in paragraph 7.2 and after that to the dust test prescribed in paragraph 7.6.3.

It shall then satisfactorily complete a further 5,000 cycles (making 45,000 in all). After the above tests, the retractor shall operate correctly and still meet the requirements of paragraphs 6.2.5.3.1, 6.2.5.3.2, 6.2.5.3.3 and 6.2.5.3.4 above.

## **7.6 ADDITIONAL TESTS FOR SAFETY BELTS WITH RETRACTORS**

### **7.6.1 Durability of retractor mechanism**

- 7.6.1.1** The strap shall be withdrawn and allowed to retract for the required number of cycles at a rate of not more than 30 cycles per minute. In the case of ~~emergency locking~~ 'Type 4N Retractors', a snatch to lock the retractor shall be introduced at each fifth cycle.

The snatches shall occur in equal numbers at each of five different extractors, namely, 90, 80, 75, 70 and 65 per cent of the total length of the strap remaining wound on the retractor. However, where more than 900 mm is provided the above percentages shall be related to the final 900 mm of strap which can be withdrawn from the retractor.

- 7.6.1.2** A suitable apparatus for the tests specified in paragraph 7.6.1.1 above is shown in annex 3 ~~to this Regulation~~.

### **7.6.2 Locking of 'Type 4N Retractors'**

- 7.6.2.1** The retractor shall be tested once for locking when the strap has been unwound to full length less  $300 \pm 3$  mm.

- 7.6.2.1.1** In the case of a retractor actuated by strap movement, the extraction shall be in the direction in which it normally occurs when the retractor is installed in a vehicle.

- 7.6.2.1.2** When retractors are being tested for sensitivity to vehicle deceleration they shall be tested at the above extraction along two perpendicular axes, which are horizontal if the retractor is installed in a vehicle as specified by the safety belt manufacturer. When this position is not specified, the testing authority shall consult the safety belt manufacturer. One of these axes shall be in the direction ~~chosen by the technical service conducting the approval test~~ to give the most adverse conditions with respect to actuation of the locking mechanism.

- 7.6.2.2** A suitable apparatus for the tests specified in paragraph 7.6.2.1 above is described in annex 4 ~~to this Regulation~~. The design of any such test apparatus shall ensure that the required acceleration is given at an average rate of increase of acceleration at least  $25 g^1$  per second.

---

<sup>1</sup>  $1 g = 9.81 \text{ m/s}^2$



**7.6.2.5** To check conformity with the requirements of paragraph 6.2.5.3.1.3 and 6.2.5.3.1.4, the retractor shall be mounted on a horizontal table and the table tilted with speed not exceeding 2° per second until locking has occurred. The test shall be repeated with tilting in other directions to ensure that the requirements are fulfilled.

**7.6.3 Dust resistance**

**7.6.3.1** The retractor shall be positioned in a test chamber as described in annex 5 to ~~this Regulation~~. It shall be mounted in an orientation similar to that in which it is mounted in the vehicle. The test chamber shall contain dust as specified in paragraph 7.6.3.2 below. A length of 500 mm of the strap shall be extracted from the retractor and kept extracted, except that it shall be subjected to ten complete cycles of retraction and withdrawal within one or two minutes after each agitation of the dust. For a period of five hours, the dust shall be agitated every twenty minutes for five seconds by compressed air free of oil and moisture at a gauge pressure of  $5.5 \times 10^5 \pm 0.5 \times 10^5$  Pa entering through an orifice,  $1.5 \pm 0.1$  mm in diameter.

**7.6.3.2** The dust used in the test described in paragraph 7.6.3.1 above shall consist of about 1 kg of dry quartz. The particle size distribution is as follows:

- (a) passing 150 µm aperture, 104 µm wire diameter: 99 to 100 per cent;
- (b) passing 105 µm aperture, 64 µm wire diameter: 76 to 86 per cent;
- (c) passing 75 µm aperture, 52 µm wire diameter: 60 to 70 per cent.

**7.6.4 Retracting force**

**7.6.4.1** ~~withdrawal and~~ retracting force shall be measured with the safety belt assembly fitted to a dummy as for the dynamic test ~~prescribed in paragraph 7.7~~. The strap tension shall be measured at the point of contact with (but just clear of) the dummy while the strap is being retracted at the approximate rate of 0.6 metres per minute.

Annex 3

DIAGRAM OF AN APPARATUS TO TEST DURABILITY OF RETRACTOR  
MECHANISM

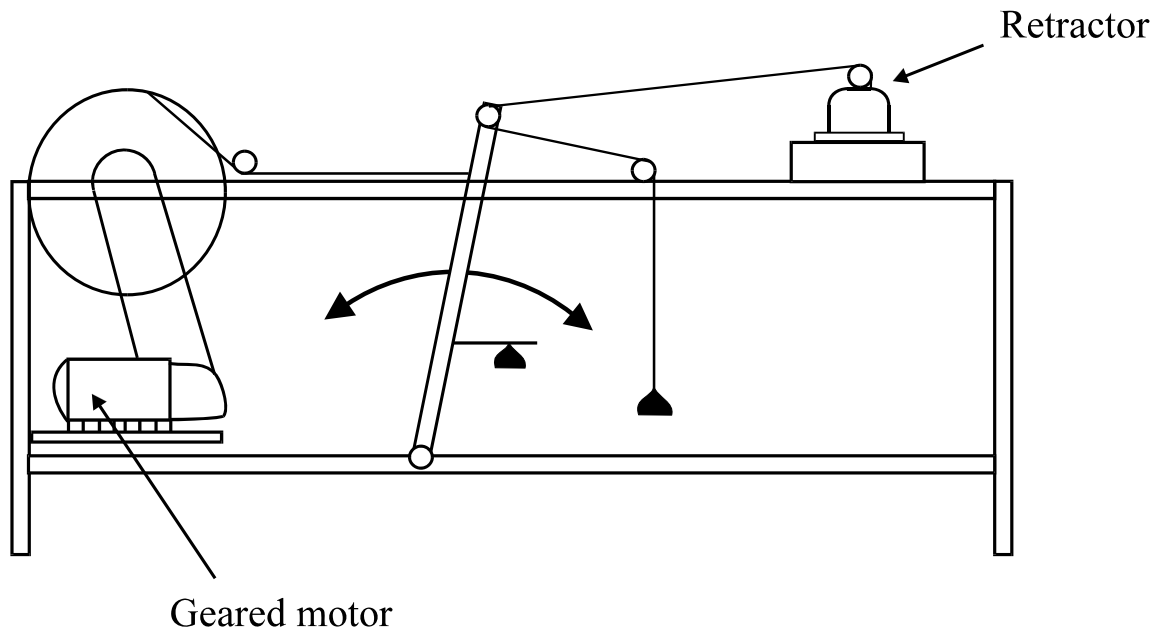

#### Annex 4

### DIAGRAM OF AN APPARATUS TO TEST LOCKING OF EMERGENCY LOCKING 'TYPE 4N RETRACTORS'

A suitable apparatus is illustrated in the figure and consists of a motor-driven cam, the follower of which is attached by wires to a small trolley mounted on a track. The cam design and motor speed combination are such as to give the required acceleration at a rate of increase of acceleration as specified in paragraph 7.6.2.2 of this Regulation Annex and the stroke is arranged to be in excess of the maximum permitted webbing movement before locking.

On the trolley a carrier is mounted which can be swivelled to enable the retractor to be mounted in varying positions relative to the direction of movement of the trolley.

When testing retractors for sensitivity to strap movement the retractor is mounted on a suitable fixed bracket and the strap is attached to the trolley.

When carrying out the above tests any brackets, etc. supplied by the manufacturer or his accredited representative shall be incorporated in the test installation to simulate as closely as possible the intended installation in a vehicle.

Any additional brackets, etc. that may be required to simulate the installation as intended in the vehicle shall be provided by the manufacturer or his accredited representative.

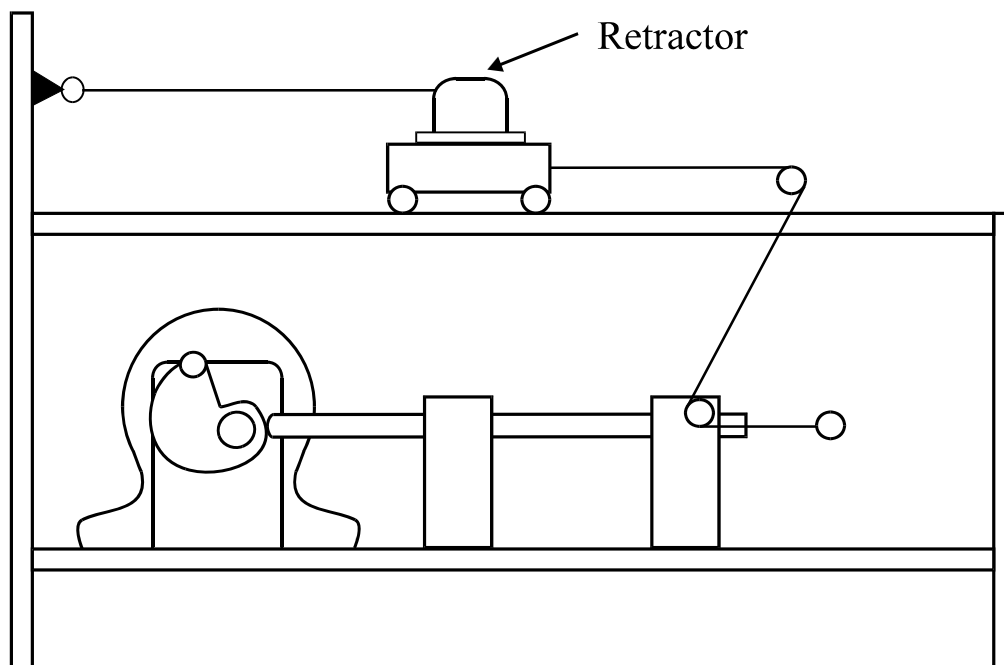

**Annex 5**

**DIAGRAM OF AN APARATUS FOR DUST-RESISTANCE TEST**

