



Vehicle Standard (Australian Design Rule 5/03 – Anchorages for Seatbelts) 2006

I, JAMES ERIC LLOYD, Minister for Local Government, Territories and Roads,
determine this vehicle standard under subsection 7 (1) of the *Motor Vehicle Standards
Act 1989*.

Dated 31 July 2006

[SIGNED]

James Eric Lloyd

Minister for Local Government, Territories and Roads

CONTENTS

1.	LEGISLATIVE PROVISIONS.....	3
2.	FUNCTION AND SCOPE.....	3
3.	APPLICABILITY AND IMPLEMENTATION.....	3
4.	DEFINITIONS	5
5.	REQUIREMENTS	5
6.	SASH GUIDE REQUIREMENTS	8
7.	LOCATION OF ANCHOR POINTS AND SASH LOCATION POINTS	11
8.	TESTING OF ANCHORAGES	12
9.	TEST OF SASH GUIDE.....	13
10.	SEATING POSITIONS	14
11.	AREA A AND AREA B	15
12.	GENERAL REQUIREMENTS FOR ANCHORAGES FOR VEHICLE CATEGORIES MD3, MD4, ME, NB2 AND NC ONLY	16
13.	ALTERNATIVE STANDARDS	18

1. LEGISLATIVE PROVISIONS

1.1. NAME OF STANDARD

1.1.1. This Standard is the Vehicle Standard (Australian Design Rule 5/03 – Anchorages for Seatbelts) 2006.

1.1.2. This Standard may also be cited as Australian Design Rule 5/03 — Anchorages for Seatbelts.

1.2. COMMENCEMENT

1.2.1. This Standard commences on the day after it is registered.

1.3. REPEAL

1.3.1. This Standard repeals each vehicle standard with the name Australian Design Rule 5/03 — Anchorages for Seatbelts that is:

(a) made under section 7 of the Motor Vehicle Standards Act 1989; and

(b) in force at the commencement of this Standard.

1.3.2. This Standard also repeals each instrument made under section 7 of the Motor Vehicle Standards Act 1989 that creates a vehicle standard with the name Australian Design Rule 5/03 — Anchorages for Seatbelts, if there are no other vehicle standards created by that instrument, or amendments to vehicle standards made by that instrument, that are still in force at the commencement of this Standard.

2. FUNCTION AND SCOPE

The function of this Australian Design Rule is to specify requirements for ‘Anchorages’ for ‘Seatbelt Assemblies’ so that they may be adequately secured to the vehicle structure or ‘Seat’ and will meet comfort requirements in use.

NOTE: The seatbelt ‘Anchorage’ is not for any other purpose, e.g. securing loads etc.

3. APPLICABILITY AND IMPLEMENTATION

3.1. Applicability Summary

3.1.1. This ADR applies to the design and construction of vehicles as set out in the table below.

3.1.2. For Omnibuses complying with ADR 68/... only the Driver’s ‘Seat’ is required to comply with clause 5.1.2 of this rule.

3.1.3. Where ECE R 14/02 was used as the Alternative Standard, vehicles certified to the requirements of an Acceptable Prior Rule for a particular category as shown in the Applicability Table are deemed to comply with this rule.

3.2. Applicability Table

Vehicle Category	ADR Category Code*	UNECE Category Code*	Manufactured on or After	Acceptable Prior Rules
Moped 2 wheels	LA	L1	Not Applicable	
Moped 3 wheels	LB	L2	Not Applicable	
Motor cycle	LC	L3	Not Applicable	
Motor cycle and sidecar	LD	L4	Not Applicable	
Motor tricycle	LE	L5		
	LEM		Not Applicable	
	LEP		1 July 1996	/02
	LEG		1 July 1996	/02
Passenger car	MA	M1	1 July 1996	/00 /01 /02
Forward-control passenger vehicle	MB	M1	1 July 1996	/00 /01 /02
Off-road passenger vehicle	MC	M1	1 July 1996	Nil
Light omnibus	MD	M2		
up to 3.5 tonnes 'GVM' and up to 12 seats	MD1		1 July 1996	/00 /01 /02
up to 3.5 tonnes 'GVM' and more than 12 seats	MD2		1 July 1996	/02
over 3.5 tonnes and up to 4.5 tonnes 'GVM'	MD3		1 July 1996	/02
over 4.5 tonnes and up to 5 tonnes 'GVM'	MD4		1 July 1996	/02
Heavy omnibus	ME	M3	1 July 1996	/02
Light goods vehicle	NA	N1	1 July 1996	Nil
Medium goods vehicle	NB	N2		
over 3.5 tonnes up to 4.5 tonnes 'GVM'	NB1		1 July 1996	/00 /01 /02
over 4.5 tonnes up to 12 tonnes 'GVM'	NB2		1 July 1996	/02
Heavy goods vehicle	NC	N3	1 July 1996	/02
Very light trailer	TA	O1	Not Applicable	
Light trailer	TB	O2	Not Applicable	
Medium trailer	TC	O3	Not Applicable	
Heavy trailer	TD	O4	Not Applicable	

* The category code may also be in the format L₁, L_A etc.

4. DEFINITIONS

- 4.1. Refer to Vehicle Standard (Australian Design Rule Definitions and Vehicle Categories) 2005.

5. REQUIREMENTS

5.1. General

- 5.1.1. Seatbelt '*Anchorage*' for vehicle categories LEP, LEG, MA, MB, MC, MD1, MD2, NA and NB1 shall comply with clauses 5.2 to 11.

- 5.1.2. Seatbelt '*Anchorage*' for vehicle categories MD3, MD4, ME, NB2 and NC must comply with either:

- 5.1.2.1. clause 12; or

- 5.1.2.2. clause 5.1.1, except that the minimum total load to be applied to body block or blocks is 9 kN.

- 5.1.3. It is recommended that each '*Anchorage*' should accept a 7/16 inch - 20 UNF - 2A threaded steel bolt.

5.2. Requirements for '*Anchorage*'

- 5.2.1. Seatbelt '*Anchorage*' must be provided for all seating positions (as established in accordance with clause 10) except for light omnibuses (MD2) where '*Anchorage*' are required only for front seating positions and non-'*Protected Seats*'. (An indicative summary of '*Anchorage*' and type applicability requirements, for guidance only, is given in the following table:)

- 5.3. Design of '*Anchorage*' for '*Seatbelt Assemblies*' - All '*Anchorage*' must be designed so that '*Seatbelt Assemblies*' may be replaced readily. Any '*Anchorage*' may be designed to receive more than one '*Anchor Fitting*.'

5.4. Pelvic Restraint

For each seating position two '*Lap Anchorages*' must be available.

5.5. Upper Torso Restraint

- 5.5.1. For all front-facing front '*Outboard Seating Positions*', provision must be made for upper torso restraint.

- 5.5.2. For all front facing and rear facing '*Outboard Seating Positions*' specified in clause 5.2.1, other than specified in clauses 5.5.1 and 5.5.4, provision must be made for upper torso restraint provided that there is '*Permanent Structure*' other than the '*Seat*' above a horizontal plane located 350 mm above the '*Seating Reference Point*' and '*Rearward*' of a vertical transverse plane through the '*Upper Torso Reference Point*'. If the design provides for a '*Harness Belt*', one or two '*Harness Torso Anchorages*' must be provided.

- 5.5.3. Notwithstanding clause 5.5.2 above for LEP & LEG vehicles provision must be made for an upper torso restraint for all front facing and rear facing '*Outboard Seating Positions*' specified in clause 5.2.1 other than that specified in clause 5.5.4.

TABLE SHOWING TYPE OF SEAT BELT AND ‘Anchorages’ REQUIRED^(c)

Vehicle Category	LEP	LEG	MA	MB	MC	MD1	MD2	MD3 ⁽⁶⁾	MD4 ⁽⁶⁾	ME ⁽⁶⁾	NA	NB1	NB2	NC
Front Row ‘Seats’														
Driver	R	R	R	R	R	R	R	R	R	L/R	R	R	R	L/R
Outboard Passenger	R	R	R	R	R	R	R	R ⁽⁵⁾	R ⁽⁵⁾	L ⁽⁴⁾	R	R	R	L/R
Centre	L	L	L	L	L	L	L	L ⁽⁴⁾	L ⁽⁴⁾	L ⁽⁴⁾	L	L	L	L
2nd Row ‘Seats’														
Outboard ⁽¹⁾	R	L/S	R	R	R	R	L/S ⁽⁴⁾	L ⁽⁴⁾	L ⁽⁴⁾	L ⁽⁴⁾	R	L/S	L	L
Centre	L	L	L	L	L	L	L ⁽⁴⁾	L ⁽⁴⁾	L ⁽⁴⁾	L ⁽⁴⁾	L	L	L	L
3rd etc. Row ‘Seats’														
Outboard ⁽²⁾	L/S	L/S	L/S	R	L/S	R	L/S ⁽⁴⁾	L ⁽⁴⁾	L ⁽⁴⁾	L ⁽⁴⁾	L/S	L/S	L	L
Centre	L	L	L	L	L	L	L ⁽⁴⁾	L ⁽⁴⁾	L ⁽⁴⁾	L ⁽⁴⁾	L	L	L	L
Vehicle Category	LEP	LEG	MA	MB	MC	MD1	MD2	MD3	MD4	ME	NA	NB1	NB2	NC

Where:

L = At least ‘Lap Anchorage’

L/S = Lap/Sash = Pelvic Restraint + Upper Torso Restraint

R = Lap/Sash with Retractor

L/R = At least ‘Lap Anchorages’ with Retractor

NOTES:

- (1) If no ‘Permanent Structure’, then ‘Lap Anchorages’ are acceptable.
- (2) If ‘Seat’ is adjustable for conversion of occupant space to luggage or goods space and is not an outboard ‘Seat’ in the front or second row of ‘Seats’ then ‘Lap Anchorages’ are acceptable.
- (3) Upper torso restraint ‘Anchorages’ must not be provided for side-facing ‘Seats’ (see clause 5.5.5).
- (4) Except for ‘Route Service Omnibuses’ ‘Anchorages’ are to be provided for non-‘Protected Seats’
- (5) If ‘Protected Seat’ then ‘Lap Anchorages’ are acceptable.
- (6) For Omnibuses complying with ADR 68/... this table only applies to the driver’s seating position.

5.5.4. Optional ‘Anchorages’

5.5.4.1. For LEP, LEG, MA, MC, MD1, NA and NB1 vehicles, provision of upper torso restraint must be optional in the case of ‘Outboard Seating Positions’ where the ‘Seat’ is designed to provide adjustment for conversion of occupant space to luggage or goods space and such seating positions are not the driver’s or front passenger seating positions or the seating positions immediately to the rear thereof.

5.5.5. Upper torso restraint must not be provided for side-facing seating positions.

5.6. Location of ‘Anchorages’

The location of ‘Anchorages’ must be such that the locations of their appropriate ‘Anchor Points’ meet the requirements of clause 7.

- 5.7. Strength of *'Anchorages'*
- 5.7.1. Testing of *'Anchorages'* must be in accordance with the requirements of clause 8.
- 5.7.2. Each *'Anchorage'* must be capable of supporting, for not less than one second, the load imposed on it by a body block subjected to the appropriate load as specified in clause 5.7.4, the body block being attached to the *'Anchorage'* under test and another *'Anchorage'* as specified in clause 8.4.1.
- 5.7.3. An *'Anchorage'* may be tested in a test relevant to that *'Anchorage'* only or in combination with tests on other *'Anchorages'*.
- 5.7.4. The loads to be applied to body blocks for testing of *'Anchorages'* must be as specified in the following Table 1:
- 5.8. Symmetrical *'Anchorages'*
- Except where the requirements of clause 5.9 apply, in cases where two *'Anchorages'* are identical in design and symmetrically located relative to the vertical longitudinal plane through the geometric centre of the vehicle, a test on one *'Anchorage'* must be considered also as a test on the other.
- 5.9. Adjacent and Multiple *'Anchorages'*
- 5.9.1. For the purposes of this clause, a single *'Anchorage'* which provides for two seating positions must be regarded as 2 *'Anchorages'*.
- 5.9.2. All *'Anchorages'* which are provided for different seating positions and which are separated by not more than 200 mm must be tested simultaneously, except that:
- 5.9.2.1. if one seating position faces to the front and the other to the rear, the *'Anchorages'* must be tested independently; and
- 5.9.2.2. notwithstanding the requirements of clause 5.7, the minimum total load to be applied to the body block or blocks for testing one *'Anchorage'* common to both pelvic and upper torso restraint may be limited to 17.7 kN.
- 5.10. *'Anchorages'* on Pillars
- 5.10.1. In cases where a *'Lap Anchorage'* and either a *'Final Torso Anchorage'* or a *'Sash Guide'* which is a load bearing *'Sash Guide'* as described in clause 6.1.2, are both located on a pillar which is in the vicinity of the front *'Seat'* back and which joins the roof to the under body structure, the pillar must be capable of supporting, for not less than one second, the loads imposed on it by body blocks subjected to loads totalling 26.6 kN such that:
- 5.10.1.1. not less than 13.3 kN is applied to the body block attached to the *'Final Torso Anchorage'* or *'Sash Guide'* as appropriate and another *'Anchorage'* as specified in clause 8.4.1; and

TABLE 1	
‘ANCHORAGE’ UNDER TEST	MINIMUM TOTAL LOAD TO BE APPLIED TO BODY BLOCK OR BLOCKS
‘ <i>Lap Anchorages</i> ’ provided for ‘ <i>Lap Belt</i> ’ system only.	22.0 kN for front-facing and side-facing seating positions. 9.0 kN for rear-facing seating positions.
‘ <i>Anchorage</i> ’ common to both pelvic and upper torso restraint in a ‘ <i>Lap-Sash Belt</i> ’ or ‘ <i>Harness Belt</i> ’ system.	22.0 kN for front-facing seating positions. 9.0 kN for rear-facing seating positions.
‘ <i>Lap Anchorages</i> ’ provided for pelvic restraint only in a ‘ <i>Lap-Sash Belt</i> ’ system.	13.3 kN for front-facing seating positions. 5.3 kN for rear-facing seating positions.
‘ <i>Final Torso Anchorages</i> ’ and ‘ <i>Harness Torso Anchorages</i> ’.	17.7 kN for front-facing seating positions. 7.0 kN for rear-facing seating positions.

5.10.1.2. the balance of the load is applied to a body block attached to the ‘*Lap Anchorage*’ and another ‘*Anchorage*’ as specified in clause 8.4.1.

5.10.1.3. Testing to the requirements of this clause may be incorporated in a test conducted in accordance with the provisions of clause 5.7.

5.11. Adjustable Upper Torso ‘*Anchorages*’

In cases where one or more ‘*Anchorages*’ are adjustable, the ‘*Anchorages*’ must be capable of meeting the relevant strength requirements of clauses 5.7, 5.9 and 5.10 with the ‘*Anchorages*’ in any position of adjustment.

5.12. Adjustable ‘*Sash Location Points*’

In cases where an ‘*Anchorage*’ is fitted with a ‘*Sash Guide*’ system incorporating an adjustable ‘*Sash Location Point*’, the ‘*Anchorage*’ must be capable of meeting the relevant strength requirements of clauses 5.7, 5.9 and 5.10 with the ‘*Sash Location Point*’ set in any position of adjustment.

6. SASH GUIDE REQUIREMENTS

6.1. General

6.1.1. The ‘*Sash Guide*’ must be nominated by the vehicle ‘*Manufacturer*’ as being either:

6.1.1.1. a component of a ‘*Seatbelt Assembly*’; or

- 6.1.1.2. not a component of a ‘*Seatbelt Assembly*’. This latter category must include those ‘*Sash Guides*’ which are not intended to be replaced when the ‘*Seatbelt Assembly*’ is replaced.
- 6.1.2. For the purpose of this Rule, a load bearing ‘*Sash Guide*’ means a ‘*Sash Guide*’ which remains integral with its supporting structure and retains the ‘*Strap*’ under the following loading conditions:
- 6.1.2.1. the ‘*Anchorage*’ test loads specified in clause 5.7; or
- 6.1.2.2. in the case where the ‘*Sash Guide*’ is a component of a ‘*Seatbelt Assembly*’, both the Dynamic Testing Procedure of the Australian Design Rule 4/... “Seatbelts” and the static strength of assembly test of Australian Standard E35-1970, “Seat Belt Assemblies for Motor Vehicles” or Australian Standard AS 2597.10 - 1983, “Determination of Static Strength and Dummy Displacement” as specified in the Australian Design Rule 4/... “Seatbelts”.
- 6.1.3. In the case where the ‘*Sash Guide*’ is not a component of a ‘*Seatbelt Assembly*’ (as nominated in clause 6.1.1.2), then the ‘*Sash Guide*’ must comply with clause 6.8 as well as clause 4.2.7 of Australian Design Rule 4/00 and 4/01 for “Seatbelts” or clause 5.8 of Australian Design Rule 4/02 for “Seatbelts” (where applicable) as if the ‘*Sash Guide*’ were part of the ‘*Seatbelt Assembly*’: (but also excluding clauses 5, 9 and 14 of Australian Standard 2596-1983, “Seat Belt Assemblies for Motor Vehicles” or clauses 3, 7 and 11 of Australian Standard E35 Pt. 1-1970, “Seat Belt Assemblies for Motor Vehicles”), clause 4.3.3 and clause 4.5.1 of Australian Design Rule 4/00 and 4/01 for “Seatbelts” or clauses 6.3 and 8.1 of Australian Design Rule 4/02 for “Seatbelts”.
- 6.2. Provision
- A ‘*Sash Guide*’ must be provided for each seating position to be fitted with a ‘*Lap-Sash Belt*’.
- 6.3. Strength
- Except in cases where the ‘*Anchor Fitting*’ at the ‘*Final Torso Anchorage*’ is the ‘*Sash Guide*’, the ‘*Sash Guide*’ must, when tested in accordance with the requirements of clause 9.1, withstand the loads in such a way that after application and removal of the loads there is no substantial deformation and the ‘*Sash Guide*’ remains integral with its supporting structure and continues to retain the ‘*Strap*’.
- 6.4. ‘*Seat*’ Backs
- In cases where the ‘*Seat*’ back is a ‘*Sash Guide*’ device the design of the ‘*Seat*’ back must be such that it is not possible for the ‘*Strap*’ to fall below the lower boundary of ‘*Area A*’ at any point not greater than 300 mm from the ‘*Seating Reference Plane*’. If this requirement is met by the use of a positive restraining device incorporated with or attached to the ‘*Seat*’ back then the device must be designed to withstand a load of 50 N applied in a horizontal transverse direction away from the ‘*Seating Reference Plane*’.

- 6.5. Design of *'Sash Guide'* Devices
- 6.5.1. In cases where the *'Sash Guide'* which includes the *'Sash Location Point'* is a load bearing *'Sash Guide'*, it must retain the *'Strap'* so that either:
- 6.5.1.1. the *'Strap'* cannot be removed from the *'Sash Guide'* without the use of tools; or
- 6.5.1.2. the *'Strap'* may be removed but returns to its design position when loads are applied.
- 6.6. *'Sash Location Point'*
- The *'Sash Guide'* must be so designed that the *'Sash Location Point'* meets the location requirements of clause 7.2.
- 6.7. Failure of *'Sash Guide'* Devices
- 6.7.1. In cases where one or more *'Sash Guides'* in the *'Sash Guide'* system are not load bearing *'Sash Guides'*, the design of the system must be such that in the installed design position:
- 6.7.1.1. the point of the first load bearing *'Sash Guide'* where the centreline of the strap first changes direction after leaving the preceding *'Sash Guide'* must be in *'Area A'* or *'Area B'*; and
- 6.7.1.2. the maximum length of *'Strap'* required to pass from that point to the *'Upper Torso Reference Point'* via the *'Sash Guide'* system must not exceed by more than 60 mm the true distance between those points.
- 6.8. Deflection of *'Sash Guides'*
- 6.8.1. In the case of a *'Sash Guide'* system where the *'Sash Guide'* which includes the *'Sash Location Point'* is a load bearing *'Sash Guide'*, and is not a component of a *'Seatbelt Assembly'* (as nominated in clause 6.1) the design must be such that:
- 6.8.1.1. in the case of a *'Sash Guide'* system with a non-adjustable *'Sash Location Point'*, the *'Sash Guide'* system must comply with clauses 6.8.2 and 6.8.3; and
- 6.8.1.2. in the case of a *'Sash Guide'* system with an adjustable *'Sash Location Point'*, the *'Sash Guide'* system must comply with clauses 6.8.2 and 6.8.4 with the *'Sash Location Point'* set in any position of adjustment.
- 6.8.2. When a load is applied as specified in clause 9.2, *'Sash Guide'* deflection must not reduce, by more than 60 mm, the actual length of *'Strap'* measured along the *'Strap'* centreline between the *'Upper Torso Reference Point'* and the final *'Anchor Point'*.
- 6.8.3. When a load is applied as specified in clause 9.2, the displaced *'Sash Location Point'* must lie in *'Area A'* or *'Area B'*.
- 6.8.4. When a load is applied as specified in clause 9.2 the displaced *'Sash Location Point'* must not lie below horizontal transverse plane DJ of *'Area A'* or horizontal transverse plane CE of *'Area B'* whichever is the lower.

6.9. Effect of 'Seat' Back Adjustment

In cases where the 'Seat' back is provided with at least one point of adjustment between the design 'Seat Back Angle' and 30° inclusive, the requirements of clauses 6.7.1.2 and 6.8.1 must be met when the 'Upper Torso Reference Point' is determined with the 'Seat' back adjusted not to the design 'Seat Back Angle' but to the greatest available 'Seat Back Angle' up to and including 30°.

7. LOCATION OF ANCHOR POINTS AND SASH LOCATION POINTS

7.1. Lap 'Anchor Points'

7.1.1. The two lap 'Anchor Points' provided for a particular seating position must lie on opposite sides of the 'Seating Reference Plane' in such a way that the sum of distances measured normal to the 'Seating Reference Plane' is not less than 165 mm.

7.1.2. The lines joining the lap 'Anchor Point' to the extreme points on the 'Pelvis Reference Locus' must be inclined to the horizontal at angles of not less than 25° nor more than 80° when viewed normal to the 'Seating Reference Plane'.

7.1.3. In cases where the line representing the centreline of the 'Strap' is not a straight line when viewed normal to the 'Seating Reference Plane' then:

7.1.3.1. with the 'Seat' in its foremost driving or riding position the line passing through the foremost point on the 'Pelvis Reference Locus' and extending 'Rearward' to the first point of contact with the 'Seat' or other device must be inclined to the horizontal at an angle of not less than 25°; and

7.1.3.2. with the 'Seat' in the rearmost driving or riding position the distance from the 'Pelvis Reference Point' to the lap 'Anchor Point' measured along the centreline of the 'Strap' must not exceed by more than 60 mm the distance from the 'Pelvis Reference Point' to the lap 'Anchor Point', except in the cases where the system is so designed that when tested in accordance with the load requirements of clause 5.7 the components of the vehicle or 'Seat' which cause the centreline of the 'Strap' between the lap 'Anchor Point' and the 'Pelvis Reference Point' to vary from a straight line, do not deflect or fail in such a manner that the effective length of the 'Strap' measured along the centreline between the lap 'Anchor Point' and the 'Pelvis Reference Point' is reduced by more than 60 mm.

7.2. 'Sash Location Point'

7.2.1. For both conditions of load specified in clause 9.1 the following requirements must be met:

7.2.1.1. the 'Sash Location Point' must be at least 140 mm from the 'Seating Reference Plane'; and

7.2.1.2. the 'Sash Location Point' must lie in 'Area A'.

- 7.2.2. Notwithstanding the requirements of clause 7.2.1, the ‘*Sash Location Point*’ may be adjustable for comfort provided that:
- 7.2.2.1. at least one point in the range of adjustment must permit the ‘*Sash Location Point*’ to comply with the requirements of clause 7.2.1;
- 7.2.2.2. no point of adjustment must cause the ‘*Sash Location Point*’ to lie below horizontal transverse plane DJ of ‘*Area A*’ for both conditions of load specified in clause 9.1; and
- 7.2.2.3. the ‘*Sash Location Point*’ must be adjustable without the use of tools.
- 7.3. Harness ‘Anchor Points’
- 7.3.1. In cases where only one harness ‘*Anchorage*’ is provided for a particular seating position, the harness ‘*Anchor Point*’ must be located:
- 7.3.1.1. ‘*Rearward*’ of transverse plane inclined at the same angle as the ‘*Torso Reference Line*’ and 500 mm horizontally ‘*Rearward*’ from the ‘*Seating Reference Point*’;
- 7.3.1.2. not more than 50 mm from the ‘*Seating Reference Plane*’; and
- 7.3.1.3. within ‘*Area B*’ but without the transverse location requirements of clause 11.2.1.
- 7.3.2. In cases where two harness ‘*Anchorages*’ are provided for a particular seating position, the two ‘*Anchor Points*’ must be located:
- 7.3.2.1. ‘*Rearward*’ of a transverse plane inclined at the same angle as the ‘*Torso Reference Line*’ and 75 mm horizontally ‘*Rearward*’ from the ‘*Seating Reference Point*’;
- 7.3.2.2. either side of the ‘*Seating Reference Plane*’ in such a way that the distances from the ‘*Seating Reference Plane*’ do not differ by more than 100 mm;
- 7.3.2.3. such that the transverse separation does not exceed 300 mm, and is either greater than 250 mm or is less than 250 mm by not more than half the horizontal distance from either ‘*Anchor Point*’ to the transverse plane through the ‘*Torso Reference Line*’; and
- 7.3.2.4. within ‘*Area B*’ but without the transverse location requirements of clause 11.2.1.

8. TESTING OF ANCHORAGES

8.1. Installation of Doors

Except in cases where the vehicle complies with the Australian Design Rule for “Door Latches and Hinges”, testing must be carried out with the vehicle doors open or removed.

8.2. Installation of ‘Seats’

The appropriate ‘*Seats*’ must be installed for the tests and located in their rearmost driving or riding position and with the ‘*Seat*’ back adjusted to the design ‘*Seat Back Angle*’ except that in cases where the line of pull could not contact a particular portion of the ‘*Seat*’ then that portion may be removed.

- 8.3. Body Blocks
Loads must be transmitted by the use of body blocks.
- 8.4. Loading of Body Blocks
- 8.4.1. Each body block must be restrained by attachments which are representative of a passing around the body block and connected to the 'Anchorage' under test and another appropriate 'Anchorage' as described in the following Table 2, by fittings that are representative of the actual 'Anchor Fittings' designed for each 'Anchorage'.
- 8.4.2. In cases where one 'Anchorage' is a 'Final Torso Anchorage', the attachment restraining the body block must pass through the 'Sash Guide' system except that:
- 8.4.2.1. it may by-pass any 'Sash Guide' which is not a load bearing 'Sash Guide'; and
- 8.4.2.2. a load bearing 'Sash Guide' which is a component of a 'Seatbelt Assembly' (as nominated in clause 6.1) may be replaced by a representative component of sufficient strength to withstand the load requirements of clause 5.7.
- 8.5. Direction of Loading
- 8.5.1. In the case of front and rear facing 'Seats', the direction of load to the body blocks must be:
- 8.5.1.1. 'Forward' of the seating position;
- 8.5.1.2. parallel to the 'Seating Reference Plane';
- 8.5.1.3. in the case of pelvic restraint, at an angle above the horizontal of not less than 5° nor more than 50°; and
- 8.5.1.4. in the case of upper torso restraint, at an angle above the horizontal of not less than 0° nor more than 20°.
- 8.5.2. In the case of side facing 'Seats', the direction of load to the body block attached to the 'Lap Anchorages' must be:
- 8.5.2.1. in a direction towards the front of the vehicle;
- 8.5.2.2. in a vertical plane inclined inboard to a vertical longitudinal plane relative to the vehicle by not more than 20°; and
- 8.5.2.3. at an angle to the horizontal of not less than 5° nor more than 50°.
- 9. TEST OF SASH GUIDE**
- 9.1. With the upper torso 'Strap' installed in the vehicle, tensile loads of 5 N and 900 N must be applied to it in a direction from the appropriate 'Sash Location Point' towards the 'Upper Torso Reference Point'.
- 9.2. With the upper torso 'Strap' installed in the vehicle, a tensile load of not less than 8.5 kN must be applied to the 'Strap' in a direction from the appropriate 'Sash Location Point' towards the 'Upper Torso Reference Point'.

TABLE 2	
'ANCHORAGE' UNDER TEST	OTHER APPROPRIATE 'ANCHORAGE'
'Lap Anchorage' provided for 'Lap Belt' system.	The other 'Lap Anchorage' for that seating position..
'Anchorage' common to both pelvic and upper torso restraint in a 'Lap-Sash Belt' system.	'Final Torso Anchorage' and/or the 'Lap Anchorage' for that seating position.
'Lap Anchorage' provided for pelvic restraint only in a 'Lap-Sash Belt' system.	'Anchorage' common to both pelvic and upper torso restraint in a 'Lap-Sash Belt' system.
'Final Torso Anchorage'.	'Anchorage' common to both pelvic and upper torso restraint in a 'Lap-Sash Belt' system.
'Anchorage' common to both pelvic and upper torso restraint in a 'Harness Belt' system.	The other 'Anchorage' common to both pelvic and upper torso restraint and/or the 'Harness Torso Anchorage'.
'Harness Torso Anchorage.'	One or both 'Anchorages' common to both pelvic and upper torso restraint in a 'Harness Belt' system.

10. SEATING POSITIONS

10.1. Single 'Seats'

A 'Seat' must be regarded as providing for one seating position only if the effective cushion width is less than 820 mm.

10.2. Multiple 'Seats'

10.2.1. If the effective cushion width is 820 mm or more, the number of seating positions must be the number of complete multiples of 410 mm unless the nature of obstructions or peculiarities of design results in the 'Seat' being 'Approved' for a lesser number of seating positions.

10.2.2. Where a 'Seat' with an effective cushion width, as determined by clause 10.3, of 1230 mm or more has its 'Seat' cushion and 'Seat' back so contoured as to provide one or two clearly identifiable seating positions, the 'Seat' will be considered as providing for two seating positions only if one or more of the following conditions are met:

10.2.2.1. where the 'Seat' consists of two separate 'Seats' with an intervening gap, which may be filled with an insert;

10.2.2.2. where there are two contoured seating positions, the lateral distance between their centrelines is less than 820 mm; or

10.2.2.3. where there is one contoured seating position the lateral distance from its centreline to the far end of the adjacent 'Seat' cushion, or to its side wall if this is less than 100 mm from the end of the cushion, is less than 1025 mm.

10.3. Effective Cushion Width

10.3.1. This is the width of the 'Seat' cushion measured horizontally at the intersection of the 'Seat' cushion with the transverse plane through the

'*Torso Reference Line*'. It is determined by an analysis of 'Seat', 'Seat' back and vehicle structure sections on the transverse plane as follows:

- 10.3.1.1. if a cushion is separated from another cushion by less than 100 mm the two cushions must be regarded as continuous;
- 10.3.1.2. if an end of the cushion is separated from adjoining structure by less than 100 mm it must be regarded as extending to the adjoining structure; and
- 10.3.1.3. should the cushion widths determined by 10.3.1.1 and 10.3.1.2 exceed the internal width of the vehicle measured through a point located 562 mm from the '*Seating Reference Point*' when measured along the '*Torso Reference Line*', then the effective cushion width must be the internal width of the vehicle determined at this height.

11. AREA A AND AREA B

11.1. 'Area A'

- 11.1.1. 'Area A' is dependent on the 'Seat Back Angle' and on its 'Transverse Distance S' from the 'Seating Reference Plane'. The 'Seat Back Angle' must be taken as the design 'Seat Back Angle'.
- 11.1.2. For a particular value of S and subject to clause 11.1.3, 'Area A' is located as follows (refer Fig. 1):
 - 11.1.2.1. above a horizontal transverse plane DJ located 450 mm above the '*Seating Reference Point*' R;
 - 11.1.2.2. to the rear of a transverse plane FK inclined downward at the rear 120° to the '*Torso Reference Line*' and passing through a point B on the '*Torso Reference Line*' and located 260 mm + S from the '*Seating Reference Point*';
 - 11.1.2.3. below a transverse plane FN inclined upward at the rear 65° to the '*Torso Reference Line*' and passing through a point C along the '*Torso Reference Line*' located 315 mm + 1.6 S from the '*Seating Reference Point*' R; and
 - 11.1.2.4. 'Forward' of a vertical transverse plane NJ located 1.3 S 'Rearward' of point M on the '*Torso Reference Line*'.
- 11.1.3. In cases where S is less than 200 mm, 'Area A' as defined in clause 11.1.2 is extended by the addition of an area KPQT constructed as follows:
 - 11.1.3.1. extend DJ to point P so that MP = 250 mm
 - 11.1.3.2. draw line DQ so that angle PDQ is 20° and angle DPQ is 90°; and
 - 11.1.3.3. extend FK to intersect DQ at point T.
- 11.2. 'Area B'
- 11.2.1. Transverse Location - 'Area B' extends transversely from a plane 140 mm from and parallel to the '*Seating Reference Plane*' and on the same side as the '*Sash Guide*'.
- 11.2.2. Longitudinal Location - In side elevation relative to the '*Seating Reference Plane*', 'Area B' is established as follows:

- 11.2.2.1. to the rear of a transverse vertical plane CD located 100 mm ‘*Rearward*’ of the ‘*Seating Reference Point*’ R;
- 11.2.2.2. above a horizontal plane CE located 400 mm above the ‘*Seating Reference Point*’ R; and
- 11.2.2.3. below a horizontal DF located 710 mm above the ‘*Seating Reference Point*’ R.
- 11.2.3. Notwithstanding the requirements of clauses 11.2.2.1, 11.2.2.2 and 11.2.2.3 above the location in side elevation may be as follows:
 - 11.2.3.1. to the rear of a point G located 555 mm above and 120 mm ‘*Rearward*’ of the ‘*Seating Reference Point*’ R;
 - 11.2.3.2. below a transverse plane GF inclined 40° above the horizontal; and
 - 11.2.3.3. above a transverse plane GE inclined 40° below the horizontal.

12. GENERAL REQUIREMENTS FOR ANCHORAGES FOR VEHICLE CATEGORIES MD3, MD4, ME, NB2 AND NC ONLY

- 12.1. Provision
 - 12.1.1. At least two ‘*Lap Anchorages*’ pelvic restraints must be provided for:
 - 12.1.1.1. the driver’s ‘*Seat*’ of an MD3, MD4 or ME vehicle; and
 - 12.1.1.2. any non-‘*Protected Seat*’ of an MD3, MD4 or ME vehicle (except for vehicles specially designed with spaces for standing passengers); and
 - 12.1.1.3. all ‘*Seats*’ of an NB2 or NC vehicle.
 - 12.1.2. Upper torso restraint must be provided for:
 - 12.1.2.1. the driver’s ‘*Seat*’ of an MD3, MD4 or NB2 vehicle; and
 - 12.1.2.2. all non- ‘*Protected Seats*’ being front-facing ‘*Outboard Seating Positions*’ in front (first) row ‘*Seats*’ of an MD3 or an MD4 vehicle (except for vehicles specially designed with spaces for standing passengers); and
 - 12.1.2.3. any front-facing ‘*Outboard Seating Position*’ in front (first) row ‘*Seats*’ of an NB2 vehicle.
 - 12.1.3. In the case of an NB2 or an NC vehicle, where the ‘*Anchorages*’ are mounted on the ‘*Seat*’ the test for the ‘*Anchorage*’ must also include a simultaneous load of 10 times the weight of the entire ‘*Seat*.’
- 12.2. Location
 - 12.2.1. In the case of a ‘*Suspension Seat*’, the two pelvic restraint ‘*Anchorages*’ must be mounted on the ‘*Seat*’ so as to maintain the positional relationship between the ‘*Anchorages*’ and the ‘*Seating Reference Point*’.
 - 12.2.2. The two lap ‘*Anchor Points*’ provided for a particular seating position must:
 - 12.2.2.1. lie on opposite sides of the ‘*Seating Reference Plane*’ in such a way that the sum of the distances measured normal to the ‘*Seating Reference Plane*’ is not less than 165 mm; and

- 12.2.2.2. meet the requirements of either clause 12.2.3 or clause 12.2.4.
- 12.2.3. The lines joining the ‘*Anchor Point*’ to the extreme points on the ‘*Pelvis Reference Locus*’ must be inclined to the horizontal at angles of not less than 25° nor more than 80° when viewed normal to the ‘*Seating Reference Plane*’.
- 12.2.4. When viewed in side elevation with the ‘*Seat*’ in the rearmost and lowest driving or riding position, the lap ‘*Anchor Points*’ must be located:
- 12.2.4.1. below a horizontal line 150 mm below the rearmost, lowest top surface of the ‘*Seat*’ cushion; and
- 12.2.4.2. ‘*Rearward*’ of a vertical line tangential to the rearmost point of the ‘*Seat*’ cushion.
- 12.2.5. There must be no specific location requirement for the ‘*Sash Location Point*’, but the requirements for passenger cars may be used as guidelines for safety and comfort.
- 12.3. Strength
- 12.3.1. ‘*Anchorages*’ located in the vehicle structure must meet either the test requirements of clause 12.3.3 or the design requirements of clause 12.3.6.
- 12.3.2. In cases where ‘*Anchorages*’ are located in ‘*Seat*’ structures it must be established either by calculation or test, in accordance with the requirements of clause 12.3.3 that the ‘*Anchorages*’ and ‘*Seat*’ anchorages will sustain the required loads.
- 12.3.3. If ‘*Anchorages*’, as specified in clauses 12.3.4 and 12.3.5, are to be proved by test, the ‘*Anchorages*’ must be tested using attachments representative of ‘*Seatbelt Assembly*’ provided. A test load of 9 kN must be applied in a ‘*Forward*’ direction at an angle, as specified in clauses 12.3.4 and 12.3.5, above the horizontal in a vertical plane parallel with the longitudinal axis of the vehicle. The test load must be sustained by the ‘*Anchorages*’ for a period of at least one second.
- 12.3.4. For ‘*Lap Anchorages*’, the pair must be tested simultaneously and the attachments must pass round an appropriate body block to which the load specified in clause 12.3.3 is applied at an angle of between 5° and 50°.
- 12.3.5. ‘*Final Torso Anchorage*’ must be tested simultaneously with the ‘*Anchorage*’ common to both pelvic and upper torso restraint and the attachments must pass round an appropriate body block to which the load specified in clause 12.3.3 is applied at an angle of between 0° and 20°.
- 12.3.6. If ‘*Anchorages*’ are to be proved by design, the ‘*Anchorages*’ must be provided in a substantial metal component. In cases where this metal component is less than 3 mm in thickness, the ‘*Anchorage*’ must include a device to distribute the load. The device must be shaped to match the contour of the mounting surface and must have an area of not less than 3750 mm² in contact with the mounting surface. The thickness of the device must not be less than 3 mm.

13. ALTERNATIVE STANDARDS

The technical requirements of ECE R 14/02 - "Safety Belt Anchorages" must be deemed to be equivalent to the technical requirements for location (clauses 5.6 and 6.6) and strength (clause 5.7) of 'Anchorages' for front-facing seating positions.

FIG 1
LOCATION OF AREA A
CONSTRUCTION DETAIL

$$\begin{aligned} CR &= 315 + 1.6 s & MJ &= 1.3 s \\ RB &= 260 + s & MP &= 250 \end{aligned}$$

Dimensions in mm

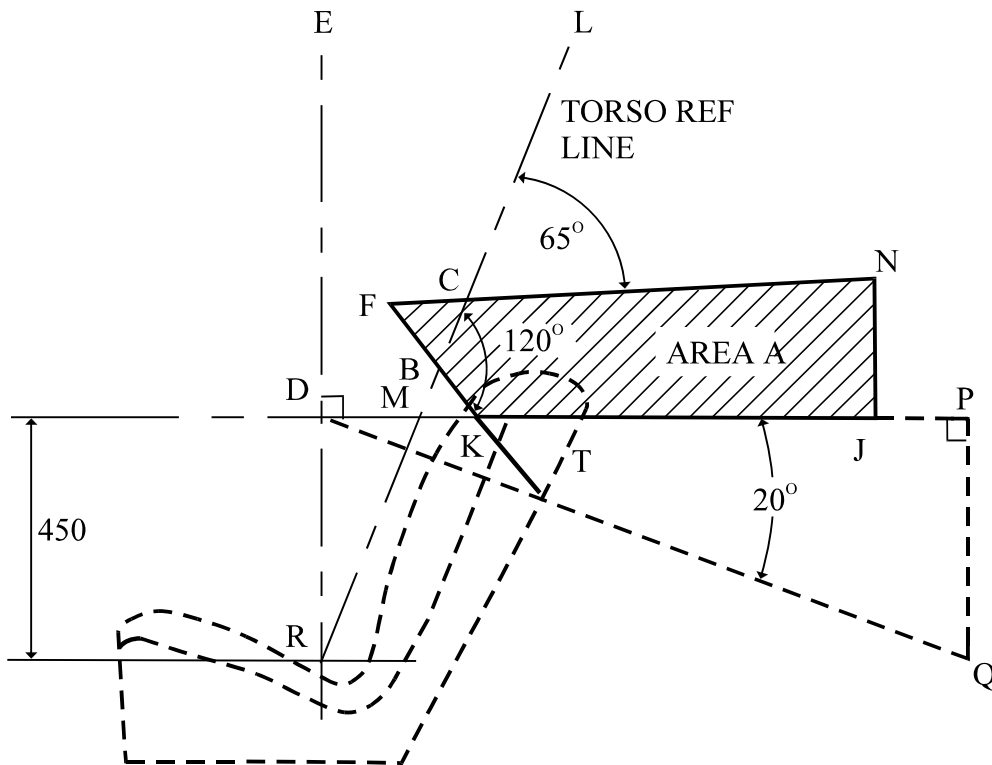

FIG 2
LOCATION OF AREA B

Dimensions in mm

