



## **Vehicle Standard (Australian Design Rule 43/00 – Vehicle Configuration and Marking) 2006**

I, JAMES ERIC LLOYD, Minister for Local Government, Territories and Roads,  
determine this vehicle standard under subsection 7 (1) of the *Motor Vehicle Standards  
Act 1989*.

Dated            10 August 2006

[SIGNED]

James Eric Lloyd

Minister for Local Government, Territories and Roads

## CONTENTS

43.0.	LEGISLATIVE PROVISIONS.....	3
	PURPOSE AND SCOPE .....	3
	APPLICABILITY .....	3
43.1.	DEFINITIONS .....	4
43.2.	TURNING CIRCLE.....	4
43.3.	MARKING .....	5
43.4.	DIMENSIONS OF VEHICLES .....	7
43.5.	PROJECTION OF ' <i>EQUIPMENT</i> ' .....	10
43.6.	' <i>AXLE</i> ' CONFIGURATION.....	10
43.7.	' <i>LOAD SHARING SUSPENSION</i> ' .....	11

**43.0. LEGISLATIVE PROVISIONS****43.0.1. NAME OF STANDARD**

43.0.1.1. This Standard is the Vehicle Standard (Australian Design Rule 43/00 – Vehicle Configuration and Marking) 2006.

43.0.1.2. This Standard may also be cited as Australian Design Rule 43/00 — Vehicle Configuration and Marking.

**43.0.2. COMMENCEMENT**

43.0.2.1. This Standard commences on the day after it is registered.

**43.0.3. REPEAL**

43.0.3.1. This Standard repeals each vehicle standard with the name Australian Design Rule 43/00 — Vehicle Configuration and Marking that is:

(a) made under section 7 of the Motor Vehicle Standards Act 1989; and

(b) in force at the commencement of this Standard.

43.0.3.2. This Standard also repeals each instrument made under section 7 of the Motor Vehicle Standards Act 1989 that creates a vehicle standard with the name Australian Design Rule 43/00 — Vehicle Configuration and Marking, if there are no other vehicle standards created by that instrument, or amendments to vehicle standards made by that instrument, that are still in force at the commencement of this Standard.

**PURPOSE AND SCOPE**

This Australian Design Rule (ADR) is part of the Australian motor vehicle standards system and is a national standard for the purposes of the Motor Vehicle Standards Act 1989.

The function of this Australian Design Rule is to specify requirements for vehicle configuration, dimensions and marking.

**APPLICABILITY**

This ADR applies to the design and construction of vehicles as set out in the table hereunder.

## 43.0.4. Applicability Table

Vehicle Category	ADR Category Code*	UNECE Category Code*	Manufactured on or After	Acceptable Prior Rules
Moped 2 wheels	LA	L1	1 July 1988	Nil
Moped 3 wheels	LB	L2	1 March 1991	Nil
Motor cycle	LC	L3	1 July 1988	Nil
Motor cycle and sidecar	LD	L4	1 July 1988	Nil
Motor tricycle	LE	L5	1 March 1991	Nil
Passenger car	MA	M1	1 July 1988	Nil
Forward-control passenger vehicle	MB	M1	1 July 1988	Nil
Off-road passenger vehicle	MC	M1	1 July 1988	Nil
Light omnibus	MD	M2		
up to 3.5 tonnes 'GVM' and up to 12 seats	MD1		1 July 1988	Nil
up to 3.5 tonnes 'GVM' and more than 12 seats	MD2		1 July 1988	Nil
over 3.5 tonnes and up to 4.5 tonnes 'GVM'	MD3		1 July 1988	Nil
over 4.5 tonnes and up to 5 tonnes 'GVM'	MD4		1 July 1988	Nil
Heavy omnibus	ME	M3	1 July 1988	Nil
Light goods vehicle	NA	N1	1 July 1988	Nil
Medium goods vehicle	NB	N2		
over 3.5 tonnes up to 4.5 tonnes 'GVM'	NB1		1 July 1988	Nil
over 4.5 tonnes up to 12 tonnes 'GVM'	NB2		1 July 1988	Nil
Heavy goods vehicle	NC	N3	1 July 1988	Nil
Very light trailer	TA	O1	1 July 1988	Nil
Light trailer	TB	O2	1 July 1988	Nil
Medium trailer	TC	O3	1 July 1988	Nil
Heavy trailer	TD	O4	1 July 1988	Nil

**43.1. DEFINITIONS**

43.1.1. Refer to Vehicle Standard (Australian Design Rule Definitions and Vehicle Categories) 2005.

**43.2. TURNING CIRCLE**

Every vehicle, including a motor vehicle in combination with a trailer, shall have a turning circle in either direction, as determined by reference to the extreme outer edge of the tyre track at ground level, not exceeding 25 metres in diameter.

\* The category code may also be in the format L<sub>1</sub>, L<sub>A</sub> etc.

**43.3. MARKING**

## 43.3.0 Identification Number

43.3.0.1. Every vehicle shall have a unique '*Vehicle Identification Number*'

43.3.1. '*Compliance Plate*'

Every motor vehicle and every applicable trailer shall bear an '*Approved Compliance Plate*' which shall be placed in a conspicuous position on the vehicle.

## 43.3.2. Engine Number

An identification number shall be legible and permanently stamped, laser engraved, cast or a combination of these upon the main component of the engine at the time of its manufacture and such number shall be located where it can be readily seen when the engine is installed in the motor vehicle for which it intended.

## 43.3.3. Trailer Plate

43.3.3.1. On every trailer, there shall be permanently affixed a plate in a prominent external position on which is:

*'Manufacturer's' Name*

*'Date of Manufacture'*

*'Gross Trailer Mass'* (in kg).

Tyre and rim data as required by the placard specified in Australian Design Rule 24/ 'Tyre and Rim Selection'.

43.3.3.1.1. In the case where the trailer is fitted with passenger car tyres, the data specified in Clause 24.2.1 of that Rule.

43.3.3.1.2. In the case where the trailer is not fitted with passenger car tyres, the data specified in clause 24.3.1 of that Rule;

43.3.3.2. Information which is contained in the '*Compliance Plate*' does not need to be shown on the trailer plate,

## 43.3.4. Registration Plates and Labels and their Holders

## 43.3.4.1. Registration Plates

## 43.3.4.1.1. All Vehicles other than L-Group Vehicles

43.3.4.1.1.1. Provision shall be made for mounting a registration plate (as shown in Figure 1) to be affixed to the rear of the vehicle so that no part of such plate will be more than 1,300 mm from the ground.

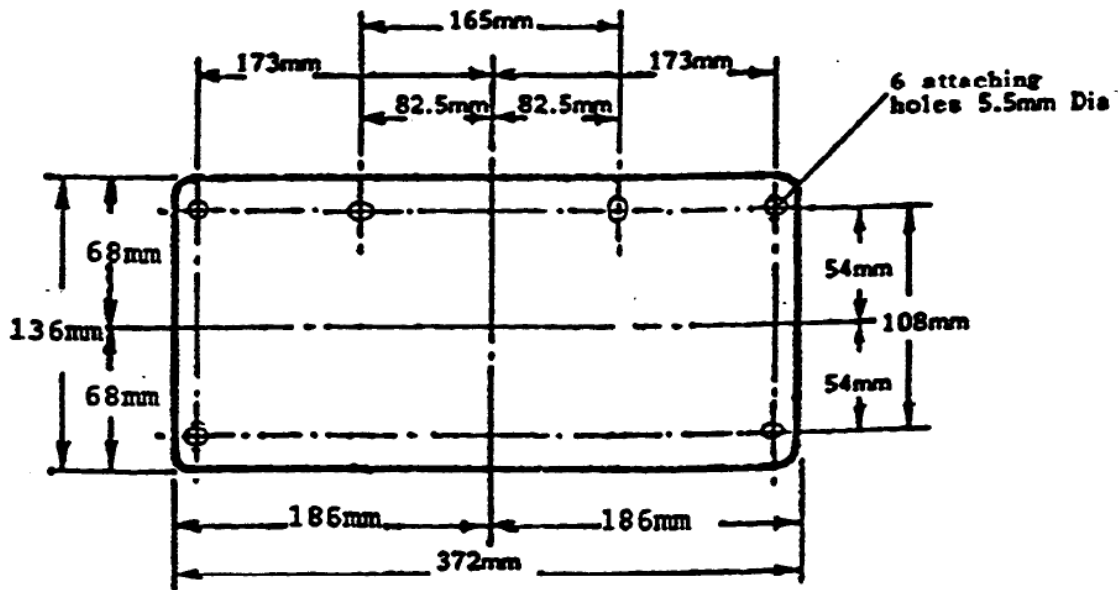

Figure 1

- 43.3.4.1.1.2. Provision shall be made for mounting a registration plate (as shown in Figure 1) to be affixed to the front of the motor vehicle forward of and parallel to the front 'Axle' so that no part of such registration plate will be more than 1,300 mm from the ground.
- 43.3.4.1.1.3. No part of a vehicle, including its standard equipment, regular production options or 'Equipment' shall be so located as to obscure any part of the registration plate(s).
- 43.3.4.1.2. L-Group Vehicles Only.
- 43.3.4.1.2.1. Provision shall be made for mounting a registration plate to the rear of the vehicle so that the centre of each registration plate shall not be less than 300 mm from the ground.
- 43.3.4.2. Label Holder
- 43.3.4.2.1. All vehicles, which have no windscreen, shall have a holder for the registration label affixed to their left-hand side in such a position as to be clearly visible to a person facing the holder at a distance of 6 metres.
- 43.3.4.2.2. For L-Group vehicles, a holder for the registration label shall be affixed in a conspicuous position on the vehicle.
- 43.3.5. Not used
- 43.3.6. Marking of 'Converter Dollies'
- All 'Converter Dollies' shall have clearly and permanently marked on their chassis:
- 43.3.6.1. the name or trademark of the 'Manufacturer'
- 43.3.6.2. the 'Manufacturer's' 'Gross Trailer Mass' rating; and
- 43.3.6.3. a unique serial number identifying the unit.

43.3.6.4. The requirements of Clauses 43.3.6.1 to 43.3.3.6.3 can be satisfied by the 'Compliance Plate' of the 'Converter Dolly'.

43.3.7. Visibility of Tray

On every vehicle which, together with the 'Equipment' thereof, is 2.2 m or more wide and which has a body of the tray type and does not have a 'Rear Marking Plate' (refer to ADR 13/... "Installation of Lighting and Light-signalling Devices") there shall be displayed by painting or otherwise across the full width of the rearmost portion of the tray of such vehicle, a horizontal band having a uniform depth of a least 75 mm and being white or silver in colour and clearly visible.

#### **43.4. DIMENSIONS OF VEHICLES**

43.4.1. 'Total Length' (including any 'Equipment')

43.4.1.1. Rigid vehicles

43.4.1.1.1. The 'Total Length' of the rigid portion of any vehicle, other than an omnibus, or a 'Semi-trailer' shall not exceed 11 m and the distance from the 'Front End' to the line from which the 'Rear Overhang' is measured shall not exceed 8.3 m.

43.4.1.1.2. Except as provided for in Clause 43.4.1.1.2.1 the 'Total Length' of a rigid omnibus shall not exceed 12.2 m and the distance from the 'Front End' to the line from which the 'Rear Overhang' is measured shall not exceed a figure equal to 8.3 m plus the amount if any, by which the 'Total Length' exceeds 11 m.

43.4.1.1.2.1. The 'Total Length' of an omnibus equipped with a 'Twin Steer Axle Group' and a 'Tandem Axle Group' operating on a specified route shall not exceed 12.8 m.

43.4.1.2. 'Semi-trailers'

43.4.1.2.1. The 'Total Length' of a 'Semi-trailer' over which the maximum width of the vehicle may be attainable shall not exceed 12.5 m.

43.4.1.2.2. The distance from the 'Point of Articulation' to the line from which the 'Rear Overhang' is measured shall not exceed 9 m.

43.4.1.2.3. The forward projection from the 'Point of Articulation' of the 'Semi-trailer' portion of an 'Articulated Vehicle' shall be contained within a radius of 1.9 m.

43.4.1.2.4. Every 'Semi-trailer' shall, when viewed in plan, be contained wholly within the envelope shown in Figure 2.

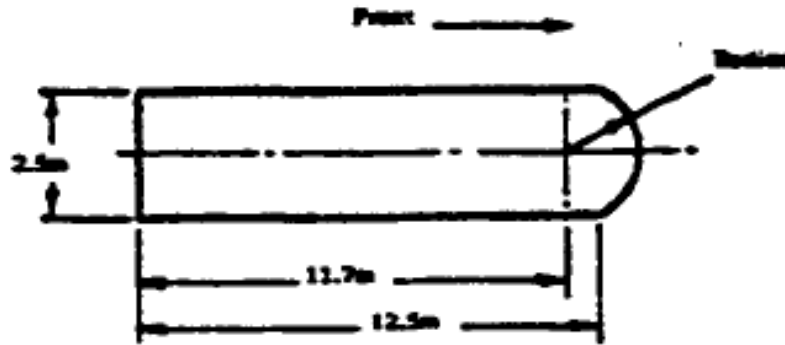

**Figure 2**

- 43.4.1.3. Non-rigid Vehicles (other than 'Road Trains', 'B-Doubles' and 'Articulated Omnibuses').
- 43.4.1.3.1. The 'Total Length' shall not exceed 17.5 m.
- 43.4.1.3.2. The 'Drawbar Length' forming part of the vehicle shall not exceed:
- 43.4.1.3.2.1. 5 m; or
- 43.4.1.3.2.2. 8.3 m in the case of trailers having a single 'Axle Group'.
- 43.4.1.4. 'Articulated Omnibuses'
- 43.4.1.4.1. The 'Total Length' of an 'Articulated Omnibus' shall not exceed 18 metres.
- 43.4.1.4.2. All parts of an 'Articulated Omnibus' except mirrors and signalling devices shall be capable of moving within a circular track having an inner radius of 5.3 m and an outer radius of 12 m.
- 43.4.2. 'Rear Overhang' (including any 'Equipment')
- 43.4.2.1. Dimensions
- 43.4.2.1.1. Except as provided in Clause 43.4.2.1.4 for a rigid motor vehicle having a 'Total Length' up to 9.5 metres, the 'Rear Overhang' shall not exceed 60 percent of the distance from the centreline of the front 'Axle' (or the front 'Axle' of a 'Twin Steer Axle Group') to the line from which 'Rear Overhang' is measured, or 3.2 metres whichever is the lesser.
- 43.4.2.1.2. For a trailer (other than a 'Semi-trailer') having a single 'Axle Group' the 'Rear Overhang' shall not exceed the length of the load space forward of the line at the rear of the vehicle from which 'Rear Overhang' is measured, or 3.7 metres whichever is the lesser.
- 43.4.2.1.3. For a 'Semi-trailer' the 'Rear Overhang' shall not exceed 50 percent of the distance between the centreline of the 'Fifth Wheel' king pin and the line from which 'Rear Overhang' of the 'Semi-trailer' is measured, or 3.2 metres, whichever is the lesser.
- 43.4.2.1.4. The 'Rear Overhang' of a rigid omnibus shall be the least of: 60 percent of the 'Wheelbase'; or for an omnibus with a 'Single Axle' towards the rear 3.2 m; or for any other rigid omnibus 3.7 m.
- 43.4.2.1.5. For all other motor vehicles and trailers (other than 'Semi-trailers') the 'Rear Overhang' shall not exceed 60 percent of the distance from the



centreline of the front 'Axle' (or the front 'Axle' of a 'Twin Steer Axle Group' to the line from which 'Rear Overhang' is measured, or 3.7 metres whichever is the lesser.

- 43.4.2.2. Not used
- 43.4.2.3. Not used
- 43.4.2.4. In the case of a vehicle fitted with 'Twin Steer Axle Group'. the front 'Axle' of that group shall be the 'Axle' used to determine permitted 'Rear Overhang' in accordance with Clause 43.4.2.1.
- 43.4.3. Height (including any 'Equipment')
- 43.4.3.1. Except as provided for in Clause 43.4.3.3 for a double-deck cattle trailer the height of any vehicle (other than a double-deck omnibus) shall not exceed 4.3 m.
- 43.4.3.2. The height of double-deck omnibus shall not exceed 4.4 m.
- 43.4.3.3. The height of a vehicle with a double-deck cattle trailer may be up to 4.6 m provided that :
- 43.4.3.3.1. the drawing vehicle shall have tandem driven rear 'Axles', and if an interaxle differential is fitted then it shall be of the positive locking type;
- 43.4.3.3.2. double-deck cattle trailers (other than 'Semi-trailers') shall have a 'Tandem Axle Group' towards the front and a 'Triaxle Group' towards the rear.
- 43.4.3.3.3. double-deck cattle 'Semi-trailers' shall have a 'Triaxle Group' towards the rear.
- 43.4.4. 'Ground Clearance'
- The 'Ground Clearance' of a vehicle, other than an L-Group vehicle, measured from a horizontal road surface to any point on the underside of the vehicle except the tyres, wheels and wheel hubs shall, under the conditions of 'Maximum Loaded Test Mass' loading as specified in the relevant braking Rule, be not less than:
- 43.4.4.1. for any point in the width of the vehicle which is within one metre fore and aft of any 'Axle', 100 mm;
- 43.4.4.2. for the mid-point between any 2 consecutive 'Axles', the dimension in millimetres obtained by multiplying the distance between the 2 'Axles' in metres by 33.33; and
- 43.4.4.3. for any other point, 'Ground Clearance' such that if the wheels of one 'Axle' are on one plane and the wheels on the next consecutive 'Axle' are on another plane which intersect the first so that the angle between them is 7 degrees 38 minutes the point will pass over the apex transverse to the vehicle formed by that intersection, as shown in Figure 3.

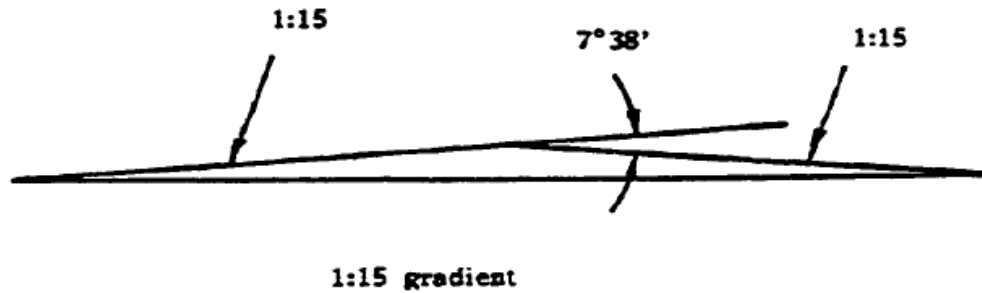

**Figure 3**

- 43.4.5. 'Overall Width' (including any 'Equipment')
- 43.4.5.1. The 'Overall Width' of any motor vehicle (other than an L-Group vehicle) or trailer shall not exceed 2,500 mm.
- 43.4.5.2. The 'Overall Width' of an L group vehicle shall be as follows :
- 43.4.5.2.1. In the case of a two wheel vehicle (LA or LC), the maximum width shall not exceed 1,000 mm.
- 43.4.5.2.2. In the case of a three wheel vehicle (LB or LE) or a motor cycle with a side car (LD), the maximum width shall not exceed 1,850 mm.

### **43.5. PROJECTION OF 'EQUIPMENT'**

- 43.5.1. For vehicles other than L-Group vehicles, any 'Equipment' shall not project more than 1,200 mm from the 'Front End' or 'Rear End'.
- 43.5.1.1. For the purposes of Clause 43.5.1, 'Equipment' shall include the pole of a 'Pole-type Trailer'.
- 43.5.2. Any 'Equipment' for L-Group vehicles (other than LD vehicles) shall not project :
- 43.5.2.1. more than 150 mm in front of the outer extremity of the front wheel or more than 300 mm behind the outer extremity of the rear wheel, or outer portion of the vehicle on either side.
- 43.5.3. Any 'Equipment' for LD vehicles only shall not project:
- 43.5.3.1. more than 600 mm in front of the outer extremity of the front wheel or more than 900 mm behind the outer extremity of the rear wheel; or
- 43.5.3.2. more than 150 mm beyond the extreme outer portion of the vehicle on either side.

### **43.6. 'AXLE' CONFIGURATION**

- 43.6.0. Vehicles shall satisfy the following requirements:
- 43.6.1. A rigid motor vehicle shall be supported by 2 'Axle' Groups' disposed as follows:
- 43.6.1.1. one towards the front of the vehicle, with all wheels connected to the steering system for that part of the vehicle, either a 'Single Axle' or a 'Twin Steer Axle Group'; and
- 43.6.1.2. one towards the rear of the vehicle by an 'Axle Group'.

- 43.6.2. A *'Semi-Trailer'* shall be supported towards the rear by an *'Axle Group'*.
- 43.6.3. A trailer other than a *'Semi-trailer'* shall be supported by either.
- 43.6.3.1. one *'Axle Group'*; or
- 43.6.3.2. an *'Axle Group'* towards both the front and rear of the trailer provided that all wheels in the front *'Axle Group'* are connected to the steering mechanism for that part of the vehicle.

**43.7. *'LOAD SHARING SUSPENSION'***

All the *'Axles'* in an *'Axle Group'* other than a *'Twin Steer Axle Group'* shall be related to each other through a *'Load Sharing Suspension'*.