



## **Vehicle Standard (Australian Design Rule 42/03 – General Safety Requirements) 2006**

I, JAMES ERIC LLOYD, Minister for Local Government, Territories and Roads,  
determine this vehicle standard under subsection 7 (1) of the *Motor Vehicle Standards  
Act 1989*.

Dated            3 September 2006

[SIGNED]

James Eric Lloyd

Minister for Local Government, Territories and Roads

**CONTENTS**

1.	LEGISLATIVE PROVISIONS.....	3
2.	FUNCTION AND SCOPE.....	3
3.	APPLICABILITY AND IMPLEMENTATION.....	3
4.	DEFINITIONS .....	4
5.	BONNET LATCHING .....	4
6.	CIGAR AND CIGARETTE LIGHTERS .....	5
7.	DIESEL ENGINES .....	5
8.	CONTROLS .....	5
9.	REAR BUMPER FOR SEMI-TRAILERS .....	5
10.	ELECTRICAL WIRING, CONNECTIONS & INSTALLATIONS .....	6
11.	EXHAUST OUTLETS.....	7
12.	EXTERNAL OR INTERNAL PROTRUSIONS .....	9
13.	FIELD OF VIEW .....	9
14.	LAVATORY CLOSETS, URINALS, BASINS AND SINKS .....	9
15.	WHEEL GUARDS (MUDGUARDS) .....	10
16.	BRAKE TUBING AND BRAKE HOSE.....	12
17.	REVERSE GEAR .....	12
18.	SLEEPER BERTHS (NB & NC VEHICLES ONLY) .....	12
19.	TELEVISION AND VISUAL DISPLAY UNITS 19.1 GENERAL .....	13
20.	WINDOWS AND VENTILATION.....	13
21.	WARNING DEVICES - AUDIBLE .....	16
22.	STABILITY REQUIREMENT (LEM, LEP & LEG VEHICLES ONLY) .....	16
23.	RETRACTABLE AXLE.....	18

## **1. LEGISLATIVE PROVISIONS**

### **1.1. NAME OF STANDARD**

1.1.1. This Standard is the Vehicle Standard (Australian Design Rule 42/03 – General Safety Requirements) 2006.

1.1.2. This Standard may also be cited as Australian Design Rule 42/03 — General Safety Requirements.

### **1.2. COMMENCEMENT**

1.2.1. This Standard commences on the day after it is registered.

### **1.3. REPEAL**

1.3.1. This Standard repeals each vehicle standard with the name Australian Design Rule 42/03 — General Safety Requirements that is:

(a) made under section 7 of the Motor Vehicle Standards Act 1989; and

(b) in force at the commencement of this Standard.

1.3.2. This Standard also repeals each instrument made under section 7 of the Motor Vehicle Standards Act 1989 that creates a vehicle standard with the name Australian Design Rule 42/03 — General Safety Requirements, if there are no other vehicle standards created by that instrument, or amendments to vehicle standards made by that instrument, that are still in force at the commencement of this Standard.

## **2. FUNCTION AND SCOPE**

The function of this vehicle standard is to specify design and construction requirements to ensure safe operation of vehicles.

## **3. APPLICABILITY AND IMPLEMENTATION**

### **3.1. Applicability Summary**

3.1.1. This national standard applies to the design and construction of vehicles as set out in the table below.

3.1.2. Where the requirements of a particular part or clause do not apply to all vehicles, the relevant categories will be identified in the part or clause heading.

3.1.3. Vehicles certified to any of the “Acceptable Prior Rules” as shown below in the Applicability Table for a particular vehicle category are deemed to comply with this national standard:

3.1.3.1. provided that they comply with the vertical exhaust configuration requirements (where appropriate) and

3.1.3.2. provided that the requirements for ‘*Retractable Axles*’ are met (where appropriate).

## 3.2. Applicability Table

Vehicle Category	ADR Category Code*	UNECE Category Code*	Manufactured on or After	Acceptable Prior Rules
Moped 2 wheels	LA	L1	1 March 1998	/00 /01 /02
Moped 3 wheels	LB	L2	1 March 1998	/00 /01 /02
Motor cycle	LC	L3	1 March 1998	/00 /01 /02
Motor cycle and sidecar	LD	L4	1 March 1998	/00 /01 /02
Motor tricycle	LE	L5	1 March 1998	/02
Passenger car	MA	M1	1 Jan 1998	/00 /01 /02
Forward-control passenger vehicle	MB	M1	1 Jan 1998	/00 /01 /02
Off-road passenger vehicle	MC	M1	1 Jan 1998	/00 /01 /02
Light omnibus	MD	M2		
up to 3.5 tonnes 'GVM' and up to 12 seats	MD1		1 July 1998	/00 /01 /02
up to 3.5 tonnes 'GVM' and more than 12 seats	MD2		1 July 1998	/00 /01 /02
over 3.5 tonnes and up to 4.5 tonnes 'GVM'	MD3		1 July 1998	/00 /01 /02
over 4.5 tonnes and up to 5 tonnes 'GVM'	MD4		1 July 1998	/00 /01 /02
Heavy omnibus	ME	M3	1 July 1998	/00 /01 /02
Light goods vehicle	NA	N1	1 July 1998	/00 /01 /02
Medium goods vehicle	NB	N2		
over 3.5 tonnes up to 4.5 tonnes 'GVM'	NB1		1 July 1998	/00 /01 /02
over 4.5 tonnes up to 12 tonnes 'GVM'	NB2		1 July 1998	/00 /01 /02
Heavy goods vehicle	NC	N3	1 July 1998	/00 /01 /02
Very light trailer	TA	O1	1 July 1998	/00 /01 /02
Light trailer	TB	O2	1 July 1998	/00 /01 /02
Medium trailer	TC	O3	1 July 1998	/00 /01 /02
Heavy trailer	TD	O4	1 July 1998	/00 /01 /02

## 4. DEFINITIONS

4.1. Refer to Vehicle Standard (Australian Design Rule Definitions and Vehicle Categories) 2005.

## 5. BONNET LATCHING

Any movable body panel forward of the windscreen that serves to cover an engine, luggage, storage or battery compartment must be provided with a latch system. A panel opening from the front which in any open position partially or completely obstructs a driver's forward view through

\* The category code may also be in the format L<sub>1</sub>, L<sub>A</sub> etc.

the windscreen must be provided with a second latch position on the latch system or with a second latch system.

## **6. CIGAR AND CIGARETTE LIGHTERS**

Deleted.

## **7. DIESEL ENGINES**

A locking device must be provided which prevents the engine from being started by any accidental or inadvertent means.

## **8. CONTROLS**

### **8.1. Steering System**

8.1.1. The centreline of the steering control must not be located to the left of the centreline of the vehicle.

8.1.2. Any component of the steering system of a motor vehicle which is essential for effective steering of the vehicle must be designed to transmit energy by mechanical means only.

8.1.2.1. Failure of any non-mechanical component of the steering system must not prevent effective steering of the vehicle.

### **8.2. Standard Controls for Automatic Transmission**

All motor vehicles, except L-group vehicles, equipped with an automatic transmission must comply with the following requirements:

8.2.1. Lever position - Deleted.

8.2.2. Lever sequence - Deleted.

8.2.3. Deleted.

8.2.4. Deleted.

8.2.5. Starter interlock

The engine starter must be inoperative when the transmission control lever is in any forward or reverse drive position.

## **9. REAR BUMPER FOR SEMI-TRAILERS**

9.1. Every '*Semi-trailer*' must be provided with a continuous rear bumper which must be so constructed and located that:

9.1.1. with the vehicle unladen, the lower edge of the bumper bar across its width must not be more than 600 mm from the ground;

9.1.2. the bumper contact surface is located not more than 600 mm forward of the rear of the vehicle and is painted white;

9.1.3. the ends of the bumper extend to within 300 mm of each side of the vehicle, unless the rearmost point of the tyres is within 600 mm of the '*Rear End*' of the vehicle, in which case the tyres must be considered as meeting the requirements over their width;

- 9.1.4. the member which is, or directly supports, the bumper contact surface is of material having no less strength than steel tubing of 100 mm outside diameter and 8 mm wall thickness; and
- 9.1.5. the structure supporting the member referred to in clause 9.1.4 can transmit no less force than that member can sustain, and provides a continuous force path to vehicle members of a strength consistent with the forces to be sustained.
- 9.2. Clause 9.1 does not apply to '*Semi-trailers*' so constructed that:
- 9.2.1. cargo access doors, tailgates or other such structures when closed afford comparable protection; and
- 9.2.2. a vertical plane tangential to the rearmost surface of the rear tyres is 155 mm or less from a parallel vertical plane containing the '*Rear End*' of the '*Semi-trailer*'.

## **10. ELECTRICAL WIRING, CONNECTIONS & INSTALLATIONS**

- 10.1. The wiring of electrical equipment other than the high tension ignition wiring must:
- 10.1.1. be supported at intervals of not more than 600 mm, except that this requirement must not apply in the case of any '*Pole-type Trailer*' which is so constructed that the length of the pole forward of the trailer frame can be adjusted;
- 10.1.2. be insulated at joints ;
- 10.1.3. be located in such a position that it cannot become overheated, cannot contact moving parts, nor constitute a fire hazard owing to its proximity to the fuel system; and
- 10.1.4. be protected from chafing. The edge of all holes in metal through which the wiring passes must be rolled or bushed with a grommet of rubber or other equivalent insulating material.
- 10.2. Electrical Connections
- 10.2.1. Except for motor vehicles over 3.5 tonnes GVM and trailers over 3.5 tonnes ATM, the electrical connectors between motor vehicles and trailers, for the purpose of operating the prescribed vehicle lighting and signalling must comply with Australian Standard 2513 1982 "Electrical Connections for Trailer Vehicles". Motor vehicles over 3.5 tonnes GVM and trailers over 3.5 tonnes ATM may use electrical connectors complying with International Standards Organisation ISO 1185 - 1997 or Society of Automotive Engineers SAE J 560 – 1998 standards for electrical connectors between towing vehicles and trailers as alternative standards.
- 10.2.2. Every trailer must be equipped with an electrical conductor independent of the trailer '*Coupling*', providing a return path between the electrical circuits of the trailer and that of the drawing vehicle.
- 10.3. Electrical installations intended for connection to a power system other than that of the drawing vehicle must be required to comply with

Australian Standard 3001-1981 “Electrical Installations in Caravans and Caravan Parks”.

**TABLE 1.1 CIRCUITS AND IDENTIFICATION.**

Future 12-pin connector	7-pin connector	Contact No	Circuit	Circuit conductor colour
		1	Left-hand turn	Yellow
2	Reversing signal	Black		
3	Earth return	White		
4	Right-hand turn	Green		
5	Service Brakes	Blue		
6	Stop lamps	Red		
7	Rear lamps, clearance and side marker lamps	Brown		
8	Battery charger/electric winch	Orange		
9	Auxiliaries, etc/battery feed	Pink		
10	Earth return	White		
11	Rear fog lamp	Grey		
12	Spare	Violet		

**Note:** Where service brakes are not fitted, contact No. 5 may be used for auxiliaries

## 11. EXHAUST OUTLETS

- 11.1. Enclosed LE vehicles, and MA, MB or MC vehicles must meet the following requirements:
- 11.1.1. the exhaust outlet must extend at least 40 mm beyond the furthest outboard or rearmost joint of the floor pan which is not continuously welded or permanently sealed which could permit direct access of exhaust gases to the passenger compartment, but not beyond the perimeter of the vehicle when viewed in plan;
- 11.1.2. the exhaust outlet, if to the side of the vehicle, must discharge to the right hand side of the vehicle and downwards at an angle to the horizontal of not less than 15 degrees and not more than 45 degrees; and
- 11.1.3. the exhaust outlet, if to the rear of the vehicle must discharge at not more than 10 degrees above or 45 degrees below the horizontal.
- 11.2. Omnibuses (MD and ME Vehicles)
- 11.2.1. the exhaust outlet must be as near as practicable to the rear of the vehicle ;
- 11.2.2. except in the case of vertical exhaust systems, the exhaust outlet must discharge rearwards or to the right of the vehicle, either horizontally or at no more than 45 degrees downwards, and must not extend beyond the perimeter of the vehicle when viewed in plan; and
- 11.2.3. when the exhaust outlet is vertical, it must be located behind the rearmost portion of the passenger compartment and may discharge either vertically upwards or rearwards at any angle above the horizontal.
- 11.3. N-Group Vehicles must meet the following requirements :
- 11.3.1. the exhaust outlet must be behind the rearmost seating position and at least 40 mm beyond the furthest outboard or rearmost joint of the floorpan which is not continuously welded or permanently sealed, and must not extend beyond the general perimeter of the vehicle when

viewed in plan. In the case of permanently enclosed vehicles not fitted with vertical exhaust systems the outlet must extend to the perimeter of the vehicle when viewed in plan;

- 11.3.2. the height of the outlet must be either greater than 150 mm above the maximum height of the cab or less than 750 mm above the ground;
- 11.3.2.1. for above-cab exhausts, the direction of discharge must not be to the left of the vehicle and must be above the horizontal ;
- 11.3.2.2. for other exhausts, the direction of discharge must not be to the left of the vehicle and must be between the horizontal and 45 degrees downwards; and
- 11.3.3. any exposed section of an exhaust system discharging above the cabin must be shielded to prevent accidental personal contact in areas where contact can occur during normal operating and servicing conditions.
- 11.4. Vertical exhaust systems, where fitted, must meet one of the following requirements:
  - 11.4.1. the orifice must be a horizontal cross-section of the exhaust pipe and must direct the exhaust gases vertically upwards; OR
  - 11.4.2. the orifice must be a horizontal cross-section of the exhaust pipe and must be fitted with a rain cap such that in plan view the hinge of the cap makes an angle of 90 degrees  $\pm$  10 degrees with the longitudinal centreline of the vehicle, with the rain cap operating in a fore-and-aft direction; OR
  - 11.4.3. the orifice must be angled and orientated so that the principal flow of the exhaust gases is directed rearwards, within 0o and 45o the longitudinal centreline of the vehicle.

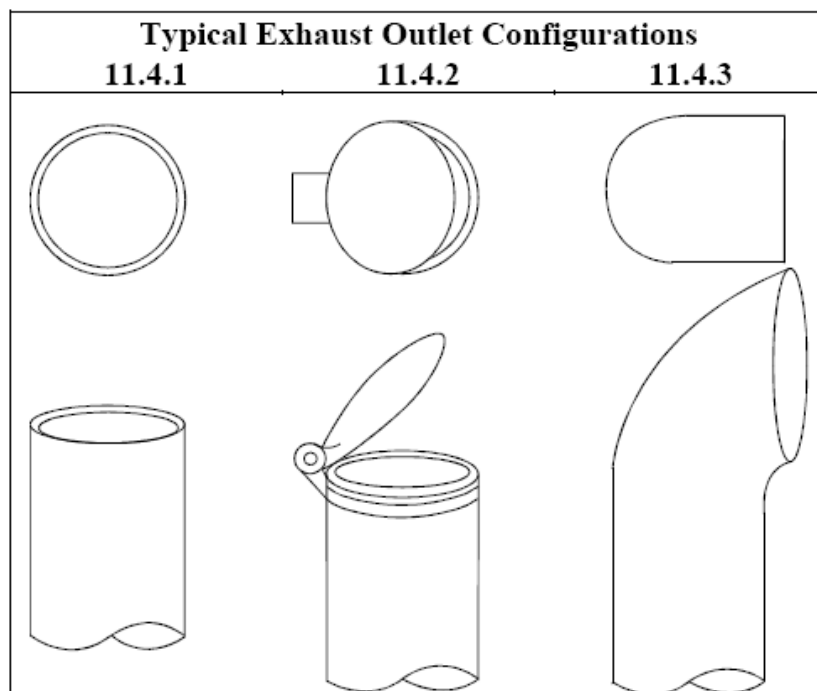



**12. EXTERNAL OR INTERNAL PROTRUSIONS**

- 12.1. No vehicle must be equipped with:
- 12.1.1. any object or fitting, not technically essential to such vehicle, which protrudes from any part of the vehicle so that it is likely to increase the risk of bodily injury to any person;
  - 12.1.2. any object or fitting technically essential to such vehicle unless its design, construction and conditions and the manner in which it is affixed to the vehicle are such as to reduce to a minimum the risk of bodily injury to any person;
  - 12.1.3. any object or fitting which, because it is pointed or has a sharp edge, is likely to increase the risk of bodily injury to any person; or
  - 12.1.4. any bumper bar the end of which is not turned towards the body of the vehicle to a sufficient extent to avoid any risk of hooking or grazing.

**13. FIELD OF VIEW**

- 13.1. A motor vehicle must not be so constructed or equipped nor must anything be affixed thereto in such a manner as to prevent the driver from having an adequate view of traffic on either side of the vehicle and in all directions in front of the vehicle to enable the vehicle to be driven with safety.
- 13.2. No motor vehicle must be so constructed such that the '*Seating Reference Points*' of any passenger seating position is more than 100 mm in front of the driver's seating position when both '*Seats*' are in the rearmost position of adjustment.
- 13.3. No motor vehicle must be constructed to provide seating for a passenger at the right-hand side of the driver.

**14. LAVATORY CLOSETS, URINALS, BASINS AND SINKS**

- 14.1. Every vehicle which is equipped with any lavatory basin, closet, urinal or sink must comply with the following requirements:
- 14.1.1. no vehicle must be equipped with a closet or urinal the contents of which can be discharged directly on the road and, except in the case of a '*Caravan*', every closet pan or urinal pan must empty into a tank carried by the vehicle, such tank being efficiently ventilated by means of a pipe the outlet of which is outside the vehicle;
  - 14.1.2. every tank into which a closet pan or urinal pan empties and, where no such tank is fitted, every closet and urinal, must contain non-inflammable and non-irritant chemicals of such character and in such quantity as to form at all times an efficient deodorant and germicide in respect of the contents of the tank, closet or urinal as the case may be; and
  - 14.1.3. no lavatory basin or sink must drain into any closet or urinal or into any tank into which a closet or urinal empties.
  - 14.1.4. The closet or urinal must vent directly to atmosphere.

**15. WHEEL GUARDS (MUDGUARDS)**

## 15.1. Wheel Guards for Passenger Cars (MA) Vehicles Only

## 15.1.1. General Requirements

The vehicle must be provided with wheel guards (parts of the bodywork, mudguards, etc) which must be so designed as to protect other road users, as far as practicable, against thrown-up stones, mud, ice, snow and water and to reduce for those users the dangers due to contact with the moving wheels.

## 15.1.2. Special Requirements

## 15.1.2.1. The wheel guards must meet the following requirements when the wheels are in the straight ahead position:

15.1.2.1.1. in the part formed by radial planes at an angle of 30 degrees to the front and 50 degrees to the rear of the centre of the wheel (see Figure 1), the overall width (q) of the wheel guards must be at least sufficient to cover the tyre '*Section Width*' (b) of the tyres fitted to the vehicle taking into account the extremes of tyre/wheel combination as specified by the '*Manufacturer*';

15.1.2.1.2. the rear of the wheel guards must not terminate above a horizontal plane 150 mm above the axis of rotation of the wheels (as measured at the wheel centres) and furthermore the intersection of the edge of the wheel guard with this plane (point A, Figure 1) must lie outside the median longitudinal plane of the tyre;

15.1.2.1.3. the contour and location of the wheel guards must be such that they are as close to the tyre as possible; and in particular within the part formed by the radial planes referred to in clause 15.1.2.1, they must satisfy the following requirements:

15.1.2.1.3.1 the projection - situated in the vertical plane of the tyre axis - of the depth (p) of the outer edge of the wheel guards, measured in the vertical longitudinal plane passing through the centre of the tyre, must be at least 30 mm. This depth (p) may be reduced progressively to zero at the radial planes specified in clause 15.1.2.1.1;

and

15.1.2.1.3.2 the distance (c) between the lower edges of the wheel guards and the axis passing through the centre of the wheels must not exceed  $2r$ , 'r' being the '*Static Loaded Tyre Radius*' of the tyre;

15.1.2.1.4. in the case of vehicles having adjustable suspension height, the above mentioned requirements must be met when the vehicle is in the normal running position specified by the '*Manufacturer*';

15.1.2.1.5. the wheel guards may consist of several components, provided that no gaps exist between or within the individual parts when assembled; and

15.1.2.1.6. the wheel guards must be securely attached. However they may be detachable either as a unit or in parts.

- 15.2. Wheel Guards for Vehicles other than MA and L-Group Vehicles
- 15.2.1. General Requirements
- All wheels of a motor vehicle or trailer (including a *'Prime Mover'* capable of operating without a *'Semi-trailer'*) must be provided with wheel guards which must be so designed as to protect other road users, as far as practicable, against thrown-up stones, mud, ice, snow and water and to reduce for those users the dangers due to contact with the moving wheels.
- 15.2.2. Special Requirements
- The wheel guards on the rearmost wheels on vehicles other than MA and L-Group vehicles must provide continuous protection between a point in area A and a point in area B in Figure 2, and must be provided for the *'Overall Tyre Width'* of all tyres.
- 15.2.2.1. In the case of steerable wheels, the requirements of clause 15.2.2 must only apply when the wheels are in the straight-ahead position.
- 15.2.3. Wheel guards may consist of either permanent body structure or part structure and other components, including mudflaps, provided the specified protection is retained during vehicle operation.
- 15.2.4. Where 2 or more *'Axles'* form an *'Axle Group'*, separate wheel guards may be provided for each rear wheel or a single wheel guard may be provided which provides continuous protection from area 'A' of the foremost wheel to area 'B' of the rearmost wheel in Figure 2.
- 15.2.5. Notwithstanding the requirements specified above the wheel guard including a mudflap (if fitted) need not be less than 230 mm from the ground for other than off-road vehicles, or 300 mm in the case of vehicles designed for off-road operation.
- 15.2.6. The requirements of this part does not apply to any vehicle the construction or use of which is such that, in the opinion of the *'Administrator'* it is unnecessary or impracticable to provide a wheel guard(s).
- 15.3. Wheel Guards for L-Group Vehicles
- 15.3.1. Wheel guards may consist of either permanent body structure or part structure and other components, including mudflaps, provided the specified protection is retained during vehicle operation.
- 15.3.2. General Requirements
- The wheels of a vehicle and the wheel of a side-car must be fitted with wheel guards of width not less than the *'Section Width'* of the tyre. The wheel guards must be so designed as to protect other road users, as far as practicable, against thrown-up stones, mud, ice, snow and water and to reduce for those users the dangers due to contact with the moving wheels.
- 15.3.3. Special Requirements
- 15.3.3.1. Rear *'Axle'* and Side-car
- The wheel guard provided for the rear wheel and for the wheel of any

side-car must extend not less than from a point vertically above the foremost part of the wheel rearward to a point not higher than the intersection of the arc of the wheel guard with a line through the centre of the wheel at 45 degrees to a horizontal plane through the centre of the wheel when a mass of 45 kg is distributed in the saddle of the vehicle at its '*Unladen Mass*'.

15.3.3.2. Front '*Axle*'

Where a wheel guard(s) is provided for the front '*Axle*', it must extend not less than from a point vertically above the centre of the wheel rearward to a point not higher than the centre of the wheel or to the point where suitable protection is afforded by the frame or other construction of the vehicle when a mass of 45 kg is distributed in the saddle of the vehicle at its '*Unladen Mass*'.

15.4. Visibility of Wheel Guards (Certain Vehicles)

Except when '*Rear Marking Plates*' are fitted, for every rear wheel guard affixed to a motor vehicle, or trailer which is 2.2 m or more in '*Overall Width*' and which has a body of the tray type, that portion of the external surface of such wheel guard which is visible to the rear of such vehicle must be white or silver in colour and clearly visible.

**16. BRAKE TUBING AND BRAKE HOSE**

Air or vacuum brake tubing and air and vacuum brake hose, flexible and hydraulic power hose between the '*Brake Power Unit 31/00*' or '*Brake Power Unit 35/00*' and the master cylinder or its equivalent (and thus not subject to ADR 7/... "Hydraulic Brake Hoses") must conform to SAA, SAE, BS, JIS, DIN, ISO or ECE Standards specified for air brake tubing or hose or vacuum brake tubing or hose or hydraulic power tubing or hose and be so fitted to the vehicle as to prevent chafing, kinking or other mechanical damage under normal motion of the parts to which they are attached.

**17. REVERSE GEAR**

All motor vehicles, excepting non-enclosed LE vehicles with an '*Unladen Mass*' of less than 450 kg and LA; LB; LC; and LD vehicles, must be capable of being so operated by the driver from the normal seating position that they may be propelled both forwards or backwards.

**18. SLEEPER BERTHS (NB & NC VEHICLES ONLY)**

18.1. Every '*Sleeper Berth*' must comply with the following requirements:

18.2. Location

It must be located within the cab or immediately adjacent thereto and must be so constructed that the occupant will not be likely to be thrown out in the event of sudden deceleration of the vehicle. It must not be located within the cargo space unless such berth is completely and securely separated from the remainder of the cargo space. It must not be located in any trailer.

### 18.3. Dimensions and Shape

It must be so constructed as to provide, at least, the following internal dimensions: 1,900 mm long measured on the centreline of the longitudinal axis, 530 mm wide for 1,200 mm along the required length and 440 mm wide for the remainder of the required length and 630 mm deep, of generally rectangular shape, except that the horizontal corners and the roof corner may be rounded to radii not exceeding 270 mm.

### 18.4. Ready Exit

It must provide the occupant, without the assistance of other persons, with at least 2 exits at opposite sides of the vehicle, each being at least 450 mm high and 530 mm wide, provided that if the berth space is part of the cab and has a doorway or opening at least 450 mm in one direction and 910 mm in another direction between it and the driving seat, the requirement for 2 exits need not apply.

### 18.5. Communication with Driver

18.5.1. Unless it is located within the driver's cab or is provided with a direct entrance thereto means must be provided to enable its occupant to communicate with the driver.

18.5.2. Such means may include telephones, speaker tubes, buzzers, pull cords, or other mechanical or electrical means.

### 18.6. Protection against Exhaust System and 'Fuel System 17/00'

It must not be so located as to permit the ready entrance of gases from the exhaust system. It must not be so located as to be overheated or damaged by reason of its proximity to the exhaust system or so located that defects in the 'Fuel System 17/00' would result in leakage on or into it.

### 18.7. Ventilation

It must be provided with louvres or other means of providing proper ventilation but must be tight against dust and rain.

## 19. TELEVISION AND VISUAL DISPLAY UNITS 19.1 GENERAL

All television receivers or visual display units and their associated equipment must be securely mounted in a position which:

19.1.1. does not obscure the driver's vision;

19.1.2. does not impede driver or passenger movement in the vehicle; and

19.1.3. is unlikely to increase the risk of occupant injury.

### 19.2. Restriction on Visibility of Screen

Unless a driver's aid, all television receivers or visual display units must be installed so that no part of the image on the screen is visible to the driver from the normal driving position.

## 20. WINDOWS AND VENTILATION

### 20.1. General Requirements

At least half the number of windows must be capable of being opened or

the vehicle must be provided with an alternative method of ventilation.

20.2. Ventilation

20.2.1. Omnibuses and N-group vehicles must be provided with a means of ventilation other than by means of windows and door openings.

20.2.2. Except in the case of omnibuses equipped with flow-through ventilation or refrigerated air-conditioning, the provision of an inlet air vent and at least two rotary vents or a hatch in the roof towards the rear of the passenger compartment as a means of ventilation is deemed to meet the provisions of this clause.

20.3. Power Operated Window Systems

20.3.1. Power operated window systems (for vehicles of category passenger car (MA); forward-control passenger vehicle (MB); and off-road passenger vehicle (MC) only)

20.3.1.1. "Power Operated Windows" are windows which are opened and closed by electric, hydraulic or pneumatic means.

20.3.2. Control of Operating Mechanism

20.3.2.1. Operation of power operated window systems must only be possible when the key that controls activation of the vehicle's engine is in the "ON", "START" or "ACCESSORY" position.

20.3.2.1.1. Exceptions are:

20.3.2.1.1.1 When the ignition switch has been actuated from "ON" to "OFF" position and/or the key has been removed and no front doors on the vehicle have been opened; or

20.3.2.1.1.2 When the key to lock the driver's door is in the door lock; or

20.3.2.1.1.3 Upon activation by a key locking system on the exterior of the vehicle; or

20.3.2.1.1.4 When the ignition key has been removed the power operated window system may:

20.3.2.1.1.4.1 remain operational for not more than 45 seconds; and

20.3.2.1.1.4.2 if the driver's window is operated within the 45 seconds period, the windows can remain operational for an additional period of not more than 45 seconds, after activation of the driver's window switch;

and

20.3.2.1.1.4.3 if the driver's door is opened within the 45 seconds period, the power operated window system can remain operational for an additional period of not more than 45 seconds, after the opening of the driver's door.

20.3.2.1.1.5 Remote closing is allowable through continuous operation of a remote actuation device provided that the remote actuation device must be incapable of closing the power window from a distance of more than 11 m from the vehicle.

20.3.2.2. For operation of rear window switches which are not situated in close proximity of the driver, the system must be designed to enable the driver to:

- 20.3.2.2.1. turn off the switch(es) of the closing mechanism(s) of the rear window(s); and
- 20.3.2.2.2. initiate opening of the rear window(s).
- 20.3.2.3. Requirement of clause 20.3.2.2.2 assumes that the rear window switch(es) which are situated out of the driver's reach, will not be operated.
- 20.3.2.4. Only momentary type switches or valves must be used for operating mechanisms to close power operated windows except for the driver's door window.
- 20.3.2.5. The requirements of clause 20.3.2.1 and clause 20.3.2.4 are not applicable if:
  - 20.3.2.5.1. the closing movement of a power window starts at an opening not exceeding 4 mm, or
  - 20.3.2.5.2. the closing of a power window of a vehicle's door without upper door frame closes from an opening not exceeding 12 mm whenever the pertinent door is closed.
- 20.3.2.6. Notwithstanding clauses 20.3.2.1 and 20.3.2.4, a power operated window system may close if it is capable of the following requirements:
  - 20.3.2.6.1. while closing, the window reverses direction before exerting a pinch force of 100N or more within the range of 200 mm to 4 mm beneath the top edge of the power window frame.
  - 20.3.2.6.2. upon such reversal, the window must open to one of the following positions:
    - A position that permits a cylindrical rod 200 mm in diameter to be placed through the opening at the top edge of the window.
    - A position that is at least as open as the position at the time closing was initiated.
    - A position at least 50 mm more open than the position at the time reversing was initiated.
  - 20.3.2.6.3. To check these devices, a measuring instrument/test rod is placed through the window '*Opening*' from the inside of the vehicle such that the cylindrical surface of the rod contacts the structure which forms the boundary of the window . The force/deflection ratio of the measuring instrument/test rod must be at least 10 N/mm. Placements of the test rods are illustrated in Figure 6.
  - 20.3.2.6.4. The technical requirements of FMVSS 118-FR VOL36 No. 232-02.12.1971- Power Operated Window System; as amended by FMVSS 118-FR VOL58 No. 6031.03.1998 are deemed to be equivalent to the technical requirements of clause 20.3 of this national standard.

**21. WARNING DEVICES - AUDIBLE**

## 21.1. General

21.1.1. No siren, repeater horn, bell, exhaust whistle or compression whistle or other device capable of producing a sound resembling that produced by any such siren, repeater horn, bell or whistle must be attached to a motor vehicle other than an emergency community service vehicle.

21.1.2. For the purpose of this clause, a repeater horn is any device which generates an audible sound (to be emitted) alternating between different tones or frequencies on a regular time cycle.

## 21.2. Warning Device

Every motor vehicle must be fitted with a least one warning device capable of giving sufficient audible warning of the presence of the vehicle. It must give an audible signal having constant amplitude and frequency characteristics. It may be powered by any energy source including compressed air.

## 21.3. Reversing Alarm

Notwithstanding clauses 21.1 and 21.2 a further device may be fitted which when and only when reverse gear is selected emits an intermittent audible signal on a regular time cycle. It must not emit a signal louder than is necessary to warn persons of the proximity of the reversing vehicle.

## 21.4. Retractable Axle Alarm

Notwithstanding clauses 21.1 and 21.2 a further device must be fitted to vehicles equipped with a '*Retractable Axle*' which emits an audible signal on the lowering of the '*Retractable Axle*'. It must not be louder than is necessary to warn persons in the proximity of the '*Retractable Axle*'.

**22. STABILITY REQUIREMENT (LEM, LEP & LEG VEHICLES ONLY)**

22.1. For LEM1, LEP1 & LEG1 vehicles the height of the centre of mass (h) must not exceed the horizontal distance from the centre of mass to the nearest roll axis (d) (See Figure 5).

22.2. For LEM2, LEP2 & LEG2 vehicles the height of the centre of mass (h) must not exceed one and a half times the horizontal distance from the centre of mass to the nearest roll axis (d) (See Figure 5).

22.3. Test procedure for determining the vehicle's centre of mass

22.3.1. Unless otherwise '*Approved*', the location of the vehicle's centre of mass must be determined by the method described below.

22.3.2. Transverse location

22.3.2.1. The transverse location of the centre of mass can be taken to be located along the vehicle's longitudinal centreline.



## 22.3.3. Longitudinal location (See Figure 3)

22.3.3.1. The longitudinal location (L) of the centre of mass, from the centre line of the front 'Axle', is determined from the formula

$$L = \frac{WR}{(F + R)}$$

where:

W is the wheelbase

R is the rear 'Axle Load' on the tyre(s) with the vehicle in the 'Maximum Loaded Test Mass' condition

F is the front 'Axle Load' on the tyre(s) with the vehicle in the 'Maximum Loaded Test Mass' condition

## 22.3.4. Height Location (See Figure 4)

22.3.4.1. For LEM1, LEP1 & LEG1 vehicles - with the vehicle standing on a level surface, mark a horizontal line parallel to the vehicle longitudinal centreline, passing through the centre of the vehicle rear 'Axle' - this is the reference line.

22.3.4.2. For LEM2, LEP2 & LEG2 vehicles - with the vehicle standing on a level surface, mark a horizontal line parallel to the vehicle longitudinal centreline, passing through the centre of the vehicle front 'Axle' - this is the reference line.

22.3.4.3. For LEM1, LEP1 & LEG1 vehicles chock both rear wheels.

22.3.4.4. For LEM2, LEP2 & LEG2 vehicles chock both front wheels.

22.3.4.5. For LEM1, LEP1 & LEG1 vehicles raise the front of the vehicle until the centre of mass is directly over the rear 'Axle'.

22.3.4.6. For LEM2, LEP2 & LEG2 vehicles raise the rear of the vehicle until the centre of mass is directly over the front 'Axle'.

22.3.4.7. Measure the angle between the reference line and the horizontal (See Figure 4).

22.3.4.8. The height of the centre of mass is given by the formula:

22.3.4.8.1. For LEM1, LEP1 & LEG1 vehicles

$$h = r + \left( \frac{(W - L)}{\tan \theta} \right)$$

where:

r is the rolling radius of the tyre fitted to the wheel

22.3.4.8.2. For LEM2, LEP2 & LEG2 vehicles

$$h = r + \left( \frac{L}{\tan \theta} \right) \quad h = r + (L / \tan \theta)$$

where:

r is the rolling radius of the tyre fitted to the wheel

22.3.5. The horizontal distance from the centre of mass to the nearest roll axis (dimension “d”) is calculated from the formula shown below:

22.3.5.1. For LEM1, LEP1 & LEG1 vehicles

$$d = L \sin \left( \arctan \left( \frac{t}{2W} \right) \right)$$

where:

d is the horizontal distance from the centre of mass to the nearest roll axis

t is the width of the wheel track of the rear ‘Axle’.

22.3.5.2. For LEM2, LEP2 & LEG2 vehicles

$$d = (W - L) \sin \left( \arctan \left( \frac{t}{2W} \right) \right)$$

where:

d is the horizontal distance from the centre of mass to the nearest roll axis

t is the width of the wheel track of the front ‘Axle’.

## 23. RETRACTABLE AXLE

23.1. Operating Safety

23.1.1. A ‘Control’ may be provided to manually move the ‘Retractable Axle’ up or down.

23.1.2. Where a manual ‘Control’ for lowering of the ‘Retractable Axle’ is fitted;

23.1.2.1. the ‘Control’ or the enclosure in which it is contained must be lockable, and

23.1.2.2. the ‘Control’ must be located within 2.5 metres of the centre-line of the ‘Axle Group’ which contains the ‘Retractable Axle’; and

23.1.2.3. the ‘Control’ must not be accessible from within the cab of the vehicle.

23.1.3. the ‘Axle(s)’ must not be able to be moved from the ‘Fully-down’ position while the load on the ‘Axle Group’ is greater than the ‘Prescribed Transition Mass’.

23.1.4. An audible warning device must be sounded as lowering begins as required by clause 21.4

23.1.5. The vehicle must be marked on both sides within 2.0 metres of a transverse vertical plane through the centre-line of the ‘Retractable Axle’ with “Warning: Axle(s) may raise or lower automatically”.

23.1.5.1. This marking must be in letter height of 25 mm minimum with red coloured letters on a white background and in such a position as to be clearly visible to a person standing nearby.

23.2. Tampering and Malfunction

- 23.2.1. Any system malfunction, attempted tampering or loss of power (e.g. trailer uncoupling) must result in the *'Retractable Axle'* moving to or staying in the *'Fully down'* position if the vehicle is loaded.

Figure 1

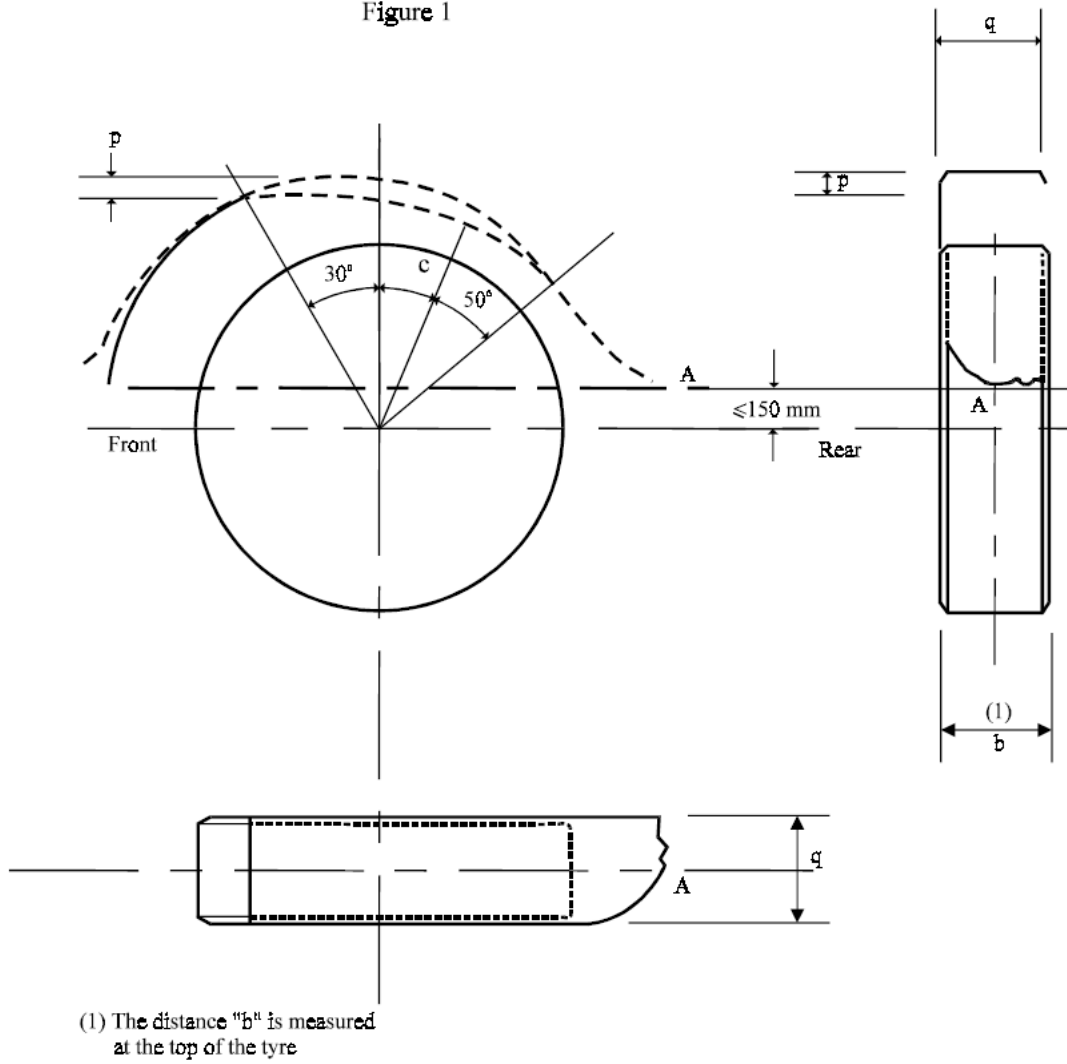
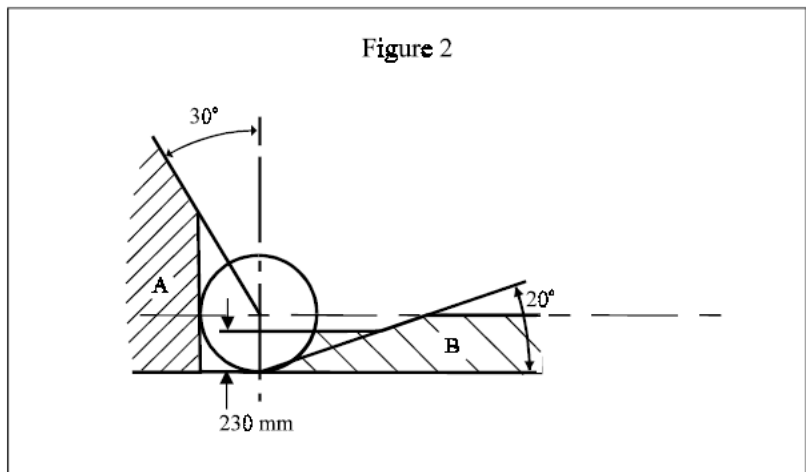
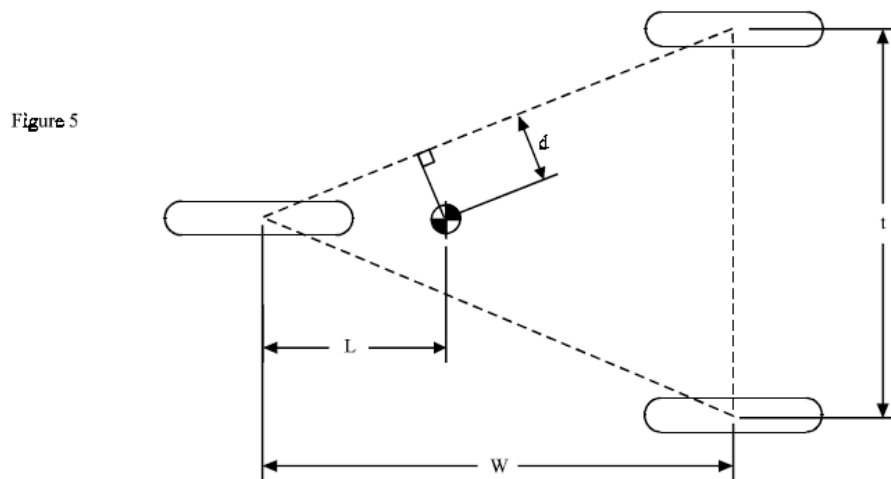
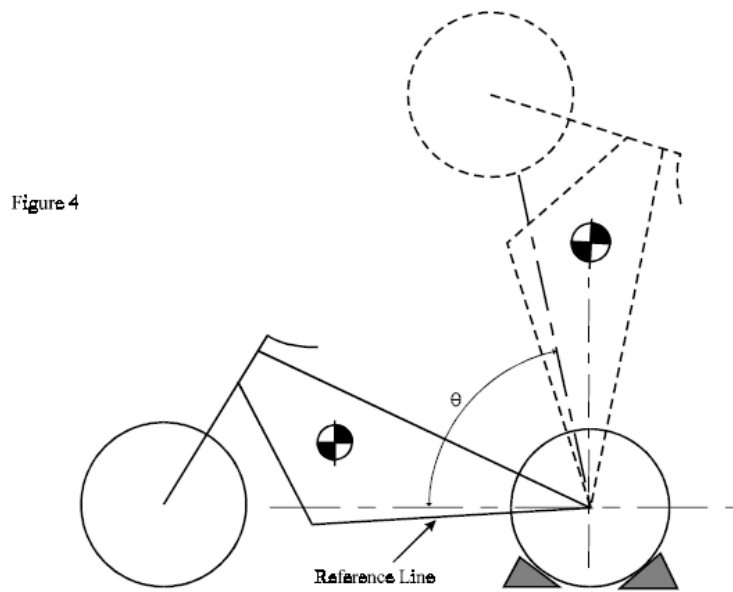
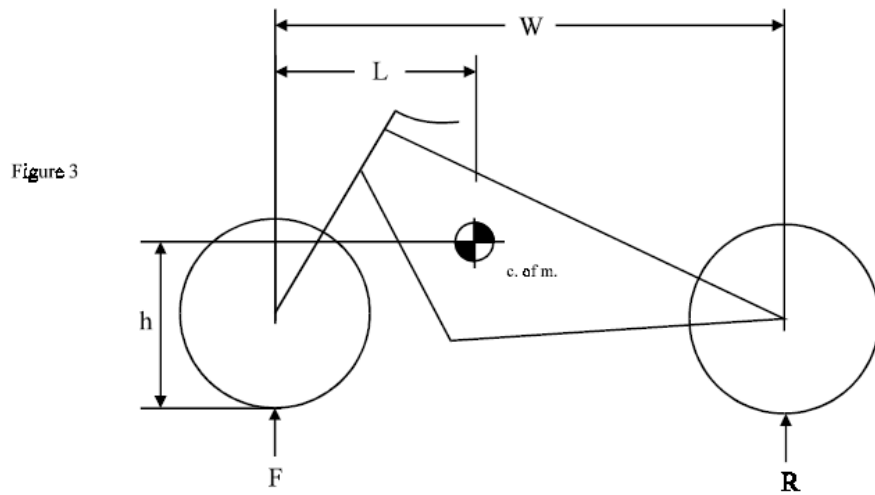
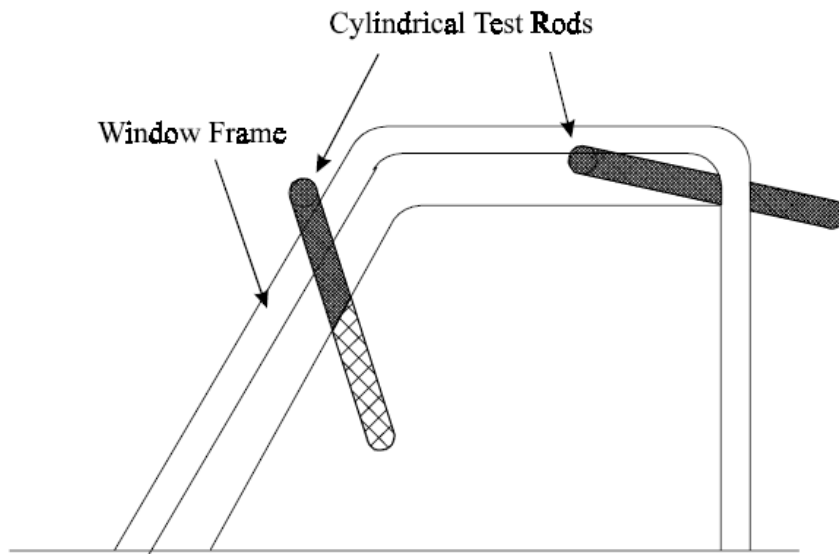

Figure 2







**Figure 6**  
**Typical Cylindrical Test Rods Protruding through**  
**Window Daylight Openings**