



Vehicle Standard (Australian Design Rule 38/00 – Trailer Brake Systems) 2006

I, JAMES ERIC LLOYD, Minister for Local Government, Territories and Roads,
determine this vehicle standard under subsection 7 (1) of the *Motor Vehicle Standards
Act 1989*.

Dated 3 September 2006

[SIGNED]

James Eric Lloyd

Minister for Local Government, Territories and Roads

CONTENTS

38.0.	LEGISLATIVE PROVISIONS.....	3
	PURPOSE AND SCOPE	3
	APPLICABILITY	3
38.1.	DEFINITIONS	5
38.2.	DESIGN REQUIREMENTS	7
38.3.	PERFORMANCE TEST REQUIREMENTS	11
38.4.	PERFORMANCE CALCULATION REQUIREMENTS	20
38.5.	ALTERNATIVE STANDARDS	25

38.0. LEGISLATIVE PROVISIONS

38.0.1. NAME OF STANDARD

38.0.1.1. This Standard is the Vehicle Standard (Australian Design Rule 38/00 – Trailer Brake Systems) 2006.

38.0.1.2. This Standard may also be cited as Australian Design Rule 38/00 — Trailer Brake Systems.

38.0.2. COMMENCEMENT

38.0.2.1. This Standard commences on the day after it is registered.

38.0.3. REPEAL

38.0.3.1. This Standard repeals each vehicle standard with the name Australian Design Rule 38/00 — Trailer Brake Systems that is:

(a) made under section 7 of the Motor Vehicle Standards Act 1989; and

(b) in force at the commencement of this Standard.

38.0.3.2. This Standard also repeals each instrument made under section 7 of the Motor Vehicle Standards Act 1989 that creates a vehicle standard with the name Australian Design Rule 38/00 — Trailer Brake Systems, if there are no other vehicle standards created by that instrument, or amendments to vehicle standards made by that instrument, that are still in force at the commencement of this Standard.

PURPOSE AND SCOPE

This Australian Design Rule (ADR) is part of the Australian motor vehicle standards system and is a national standard for the purposes of the Motor Vehicle Standards Act 1989.

The function of this Australian Design Rule is to specify requirements for braking under both normal and emergency conditions. Compliance shall be demonstrated by means of procedures outlined in the Rule for road testing and/or calculations based on data for ‘*Approved*’ components.

APPLICABILITY

This ADR applies to the design and construction of vehicles as set out in the table hereunder (except those trailers having an ‘*Aggregate Trailer Mass*’ over 4.5 tonnes and designed for use behind a drawing vehicle with a maximum speed less than 50 km/h or trailers which are otherwise specially exempted by the ‘*Administrator*’).

The Package 14 issue of /00 allows trailers under 2 tonne ‘*Aggregate Trailer Mass*’ to only brake one axle.

Vehicle Category	ADR Category Code *	UNECE Category Code *	Manufactured on or After	Acceptable Prior Rules
Moped 2 wheels	LA	L1	Not Applicable	
Moped 3 wheels	LB	L2	Not Applicable	
Motor cycle	LC	L3	Not Applicable	
Motor cycle and sidecar	LD	L4	Not Applicable	
Motor tricycle	LE	L5	Not Applicable	
Passenger car	MA	M1	Not Applicable	
Forward-control passenger vehicle	MB	M1	Not Applicable	
Off-road passenger vehicle	MC	M1	Not Applicable	
Light omnibus	MD	M2		
up to 3.5 tonnes 'GVM' and up to 12 seats	MD1		Not Applicable	
up to 3.5 tonnes 'GVM' and more than 12 seats	MD2		Not Applicable	
over 3.5 tonnes and up to 4.5 tonnes 'GVM'	MD3		Not Applicable	
over 4.5 tonnes and up to 5 tonnes 'GVM'	MD4		Not Applicable	
Heavy omnibus	ME	M3	Not Applicable	
Light goods vehicle	NA	N1	Not Applicable	
Medium goods vehicle	NB	N2		
over 3.5 tonnes up to 4.5 tonnes 'GVM'	NB1		Not Applicable	
over 4.5 tonnes up to 12 tonnes 'GVM'	NB2		Not Applicable	
Heavy goods vehicle	NC	N3	Not Applicable	
Very light trailer	TA	O1	Not Applicable	
Light trailer	TB	O2	1 July 1988	Nil
Medium trailer	TC	O3	1 July 1988	Nil
Heavy trailer	TD	O4	1 July 1988	Nil

* The category code may also be in the format L₁, L_A etc.

38.1. DEFINITIONS

- 38.1.1. Refer to Vehicle Standard (Australian Design Rule Definitions and Vehicle Categories) 2005.
- 38.1.2. Not used.
- 38.1.3. ‘*Approved Brake System*’ - is a ‘*Brake System*’ that has been certified by the ‘*Administrator*’ on the basis of it having been shown to meet the requirements of this Rule.
- 38.1.4. ‘*Average Retardation Coefficient*’ - is the average braking deceleration, from initial movement of the brake ‘*Control*’ to the trailer becoming stationary, expressed as a proportion of the acceleration due to gravity.
- 38.1.5. Not used.
- 38.1.6. ‘*Brake System*’ - all those systems and devices attached to the trailer whose primary function is to translate energy and/or information supplied by the towing vehicle into a force that restrains trailer movement.
- 38.1.7. ‘*Brake Device*’ - one element of the ‘*Brake System*’ that may consist of more than one part but which is designed to perform one or more discrete functions.
- 38.1.8. ‘*Brakes*’ - those ‘*Friction Elements*’ that are forced together by the influence of the remainder of the ‘*Brake System*’ so as to apply a restraining torque to the trailer wheels.
- 38.1.9. ‘*Control Line*’ - the device that transmits the ‘*Control Signal*’ from the towing vehicle to the first other device, or between other devices on the trailer as a boosted or relayed signal not involving significant amounts of ‘*Stored Energy*’ transfer. (Often called the service line in the case of compressed air brake systems.)
- 38.1.10. ‘*Control Signal*’ - means the signal that is provided by the towing vehicle to the trailer for control of the ‘*Service Brake System*’ in normal operation.
- 38.1.11. ‘*Control System*’ - means all the ‘*Brake Devices*’ between the trailer ‘*Brake System*’ couplings (supply and control) and the ‘*Brakes*’ actuators.
- 38.1.12. ‘*E*’ is a nominal unit of ‘*Control Signal*’ strength which, for compressed air brake systems, is shown in the table below:
- 38.1.12.1. TABLE ‘*E*’ VALUES OF ‘*CONTROL SIGNAL*’ STRENGTH

Nominal Conversions	
0.0E	Zero Compressed Air Energy Level
0.15E	15 psi = 100 kPa
0.20E	19 = 130
0.24E	22 = 155
0.31E	29 = 200
0.65E	61 = 420
1.00E	94 = 650
1.06E	100 = 690

For the purposes of this rule 1.0 E has been equated to the '*Normal Minimum Energy Level*' of compressed air brakes which, for trailers, has been nominated as 650 kPa. Values appearing in brackets after '*E*' values in this rule are the equivalent kPa values for compressed air '*Brake Systems*'. The relationship between E and other brake control mediums has not been set in this rule.

- 38.1.13. '*Emergency Brake System*' - that part of the '*Brake System*' that is controlled by a line other than the '*Control Line*' and which automatically applies in the event of trailer break-away.
- 38.1.14. '*Established Retardation Coefficient*' (ERC) - is the average braking deceleration calculated from when the energy level in the '*Brakes*' actuator reaches its final value to when the trailer becomes stationary, expressed as a proportion of the acceleration due to gravity.
- 38.1.15. '*Foundation Brakes*' - the '*Brakes*' and associated mechanical parts supplied as a unit and which are usually incorporated into a '*Brake System*' design without change. In the case of an '*S-cam*' air '*Brake System*' - the cam shaft would be included but not the slack adjuster and actuator.
- 38.1.16. '*Gross Axle Load Rating*' ('*GALR*') - the '*Manufacturer's*' specified maximum '*Axle Load*' for each '*Axle*' for which compliance with applicable '*Australian Design Rules*' has been or can be established.
- 38.1.17. '*Group Gross Axle Load Rating*' ('*GGALR*') the least of the values allowed by '*GALR*', Table 1 or that determined by '*Gross Trailer Mass*'.
- 38.1.18. Not used
- 38.1.19. '*Loaded Test Mass*' ('*LTM*') - the mass of the laden trailer when loaded such that each of its '*Axle Groups*' is loaded to the specified '*GGALRs*'.
- 38.1.20. '*Maximum Loaded Test Mass*' ('*MLTM*') - the mass of the trailer loaded to '*Gross Trailer Mass*' such that the trailer '*Axle Loads*' do not exceed the trailer '*Manufacturer's*' nominated individual '*Axle Loads*' ('*GALR*').
- 38.1.21. '*Lightly Laden Test Mass*' ('*LLTM*') is the mass of the trailer in its normal unladen condition.
- 38.1.22. '*Normal Minimum Energy Level*' is the normal operating minimum level of the energy storage devices as defined by the normal cut-in level of the storage charging system and in the case of a compressed air '*Brake System*', shall be taken as 650 kPa.
- 38.1.23. '*Parking Brake System 38/00*' - that part of the trailer '*Brake System*' which is able to apply and maintain a restraining force at two or more trailer road wheels with and without the trailer being separated from the towing vehicle.
- 38.1.24. '*S-Cam*' means a foundation brake unit which utilises the rotation of an S-shaped cam to actuate the brakes.

- 38.1.25. *'Service Brake System'* the *'Brake System'* which in proportion to the *'Control Signal'*, applies a restraining torque to the trailer wheels in normal operation.
- 38.1.26. *'Skid Limit'* - the degree of braking at which wheel lock-up commences.
- 38.1.27. Not used
- 38.1.28. *'Stopping Distance/Time'* - the distance/time from initial movement of the brake *'Control'* to the trailer becoming stationary.
- 38.1.29. Not used
- 38.1.30. *'Stored Fluid Energy'* - energy stored as compressed air, in hydraulic accumulators, or as any form of electrical energy.
- 38.1.31. *'Supply Line'* means the path by which any *'Stored Energy'* required to actuate/release the trailer *'Brakes'* is supplied from the towing vehicle connection to the first other device in the trailer *'Brake System'*.
(Normally referred to as the emergency line in a 2 line compressed air *'Brake System'*.)
- 38.1.32. Not used
- 38.1.33. *'Trailer Gross Axle Load Rating'* (TGALR) - the sum of the *'GALR'* of each *'Axle'* attached to the trailer.
- 38.1.34. *'Total Combination Mass'* (TCM) - the combined mass of the laden or unladen trailer and the towing vehicle.
- 38.1.35. *'Total Trailer Axle Load'* (TTAL) is the total force exerted by the individual axles attached to the trailer when resting on a horizontal supporting plane.
- 38.1.36. *'Unique'* - a *'Unique'* *'Brake System'* is one consisting of a particular combination of components with particular physical and dimensional properties.

38.2. DESIGN REQUIREMENTS

- 38.2.0 *'Brake Systems'* for trailers with an *'Aggregate Trailer Mass'* of up to 4.5 tonnes.
- 38.2.0.1 Every trailer shall be equipped with an efficient *'Brake System'* which, with the exception of trailers equipped with over-run *'Brakes'*, shall be so designed as to be applied by the driver of the drawing vehicle from the driver's *'Seat'* and, in the case of trailers with an *'Aggregate Trailer Mass'* of greater than 2 tonne, operates on all wheels.
- 38.2.0.2 The *'Brake System'* on trailers with a *'Gross Trailer Mass'* up to 2 tonnes may be actuated for both *'Service Brake System'* and *'Secondary Brake System'* by the over-run of the trailer.
- 38.2.0.3 Every trailer having a *'Gross Trailer Mass'* over 2 tonnes and every *'Semi-trailer'* shall be equipped with an *'Emergency Brake System'* which will cause immediate automatic application of its *'Brakes'* in the event of the trailer or *'Semi-trailer'* accidentally becoming disconnected from the drawing vehicle. *'Brakes'* so applied shall remain applied for at least 15 minutes and shall have the performance prescribed for

emergency brakes as prescribed in the Rule.

- 38.2.0.4 Trailers with an '*Aggregate Trailer Mass*' of up to 4.5 tonnes are not required to comply with other Sections of this Rule.
- 38.2.1. '*Brake System*'
- 38.2.1.1. A '*Service Brake System*' shall be fitted to all trailer wheels and be in accordance with the requirements of clause 38.2.2 ('*Service Brake System*').
- 38.2.1.2. The trailer '*Brake System*' shall be capable of being actuated from the towing vehicle by means of a connection between the trailer and towing vehicle with a performance not less than that specified for the '*Emergency Brake System*' in clause 38.2.3 after any one failure in a '*Brake Device*' in the trailer '*Brake System*'.
- 38.2.1.3. A '*Parking Brake System 38/00*' shall be fitted and shall meet the requirements of clause 38.2.4.
- 38.2.1.4. The trailer '*Brake System*' must restrain the trailer automatically, in the event of a trailer break-away with a performance not less than that specified for the '*Emergency Brake System*' specified in clause 38.2.3.
- 38.2.1.5. A '*Brake System*' which utilises '*Stored Energy*' to actuate the '*Service Brake System*' shall be designed so that when the '*Supply Line*' energy level is reduced at a rate of not less than 0.15E/sec (100 kPa/sec) the following conditions are met.
- (a) the '*Brake System*' shall not start to automatically apply the '*Brakes*' at a '*Supply Line*' energy level of more than 0.65 '*E*' (420 kPa)
AND,
 - (b) the '*Brake System*' shall start to automatically apply the '*Brakes*' at a '*Supply Line*' energy level of not less than
 - (i) 0.31 '*E*' (200 kPa) where the maximum braking effectiveness of the '*Brakes*' so applied is dependent on '*Stored Fluid Energy*' OR,
 - (ii) 0.24 '*E*' (155 kPa) where the maximum braking effectiveness of the '*Brakes*' so applied is not dependent on '*Stored Fluid Energy*', AND
 - (c) with the '*Supply Line*' energy level at 0.0 '*E*' the braking effectiveness shall be at least that specified for the '*Emergency Brake System*' in clause 38.2.3.2 ('*Emergency Brake System*').
- 38.2.1.6. The '*Brake System*' shall be designed so that no single failure in a '*Brake Device*' in the '*Service Brake System*', except of a '*Supply Line*' or '*Control Line*', shall cause the '*Brakes*' to apply on more than one axle.
- 38.2.1.7. Manual devices for the isolation of faulty devices or brake circuits may be included in the '*Brake System*' but automatic devices of the type that normally remain passive and whose function cannot readily be checked during normal operation of the trailer are not permitted. For the purposes of this clause normal operation also includes the activity of coupling and uncoupling the trailer connections.

- 38.2.1.8. Where a trailer is fitted with an auxiliary park brake release device, enabling stored energy actuation or release of any part of the '*Brake System*' to be cut out, the device must be such that the '*Brake System*' is restored to normal no later than on the resumption of the supply of '*Stored Energy*' to the trailer from the towing vehicle.
- 38.2.1.8.1. Notwithstanding clause 38.2.1.8 above, at the option of the '*Manufacturer*', the '*Administrator*' may permit other safety related devices in the '*Parking Brake System*', when such fitment would lead to increased safety in operation or to meet other specified mandatory requirements.
- 38.2.1.9. All components and devices in the '*Brake System*' shall meet or exceed at least one appropriate and recognised international, national or association standard, where such standards exist, or the relevant parts thereof. "Recognised" can be taken as meaning SAA, SAE, BS, JIS and DIN standards in addition to other standards recognised by the '*Administrator*'.
- 38.2.1.10. Brake line couplings shall not be interchangeable.
- 38.2.1.10.1. Couplings shall be polarised in accordance with AS D8 - 1971, "Hose Couplings for use with Vacuum and Air-pressure Braking Systems on Prime movers, Trailers and Semi-trailers" where applicable. i.e. Vacuum systems, '*Supply Line*', female connector; Compressed air systems, '*Supply Line*', male connector;
- or
- palm type with inboard interference lug.
- 38.2.1.11. Each air reservoir in a compressed air '*Brake System*' shall be fitted with an automatic or manual condensate drain valve at the lowest point. Where an automatic condensate valve is fitted, it shall have provision for manual operation.
- 38.2.1.12. Each '*Brake System*' shall incorporate devices which compensate for any increased movement of its components arising from wear. Such devices shall themselves contain provision for securing them throughout their working range in any position in which they may be adjusted to or to which they may themselves automatically adjust.
- 38.2.1.13. Each '*Brake System*' shall, when applied, produce a resultant braking force acting along the longitudinal centre line of the vehicle.
- 38.2.1.14. The first call on the '*Stored Energy*' shall be that of the '*Brake System*'. Any other demand for '*Stored Energy*' shall be disconnected automatically if the '*Stored Energy*' level available becomes depleted to two-thirds of '*Normal Minimum Energy Level*'.
- 38.2.1.15. Where separate methods of actuation are provided for any of the functions of the '*Brake System*', the actuation of one function shall not cause the operation of another function.
- 38.2.1.16. '*Stored Energy*' devices shall be safeguarded to prevent depletion of the '*Stored Fluid Energy*' through failure of any part of the supplying system.

38.2.2. *'Service Brake System'*

38.2.2.1. The *'Service Brake System'* shall be designed so that the braking force can be progressively increased and decreased by means of the *'Control Signal'* from the towing vehicle.

38.2.2.2. The combined total energy capacity of energy storage devices incorporated into the *'Service Brake System'* shall be not less than 8 times the combined maximum energy capacity of the service brakes actuating devices. In the case of compressed air *'Braking Systems'*, the ratio of air reservoir volume to actuator volume will be taken as being the ratio of energy capacity.

38.2.2.3. The elapsed time, as measured in accordance with the procedure specified in clause 38.3.11 for measuring brake actuation time response shall not exceed in the case of:

- (a) any brake actuator of any *'Axle Group'* on the trailer, 0.35 seconds; and
- (b) any trailer or dolly rear service coupling for towed trailers, 0.25 seconds.

38.2.2.4. The elapsed time, as measured in accordance with the procedure specified in clause 38.3.11 for measuring brake release time, shall not exceed in the case of:

38.2.2.4.1. the brake actuator on any trailer, 0.65 seconds; and

38.2.2.4.2. any, trailer or dolly, rear service coupling for towed trailers, 0.55 seconds.

38.2.2.5. Each *'Axle'* in the *'Service Brake System'* shall have an individual *'GALR'* not less than *'Axle'* torque rating shall be determined according to clause 38.3.3 (Service Brake Effectiveness) and the fade performance according to clause 38.3.4 (Service Brake Fade Effectiveness).

'Total Trailer Axle Load' at $GTM \times \frac{\text{Brake torque rating of individual 'Axle'}}{\text{Total brake torque rating of all 'Axles'}}$.

38.2.2.6. The *'Established Retardation Coefficients'* of the *'Service Brake System'* shall be between the upper and lower bounds of Figure 1 (Service Brake Effectiveness Requirement) when tested according to clause 38.3.3 (Service Brake Effectiveness).

38.2.2.7. Where a trailer is fitted with a *'Variable Proportioning Brake System'* it shall meet the requirements of clause 38.2.2.6 with the brake proportioning device/s set in the *'LTM'* position.

38.2.2.8. Notwithstanding clause 38.2.2.6 where a trailer is fitted with an *'Antilock System'*, the *'ERCs'* need only exceed the lower bound described in Figure 1.

38.2.3. *'Emergency Brake System'*

38.2.3.1. The *'Emergency Brake System'* may utilise parts of the *'Service Brake System'* on the condition that any one failure of a *'Brake Device'* in the *'Service Brake System'* does not prevent the *'Emergency Brake System'*

from achieving its performance requirement. For the purpose of this clause, the 'Brakes' and any mechanical linkage connected directly thereto, shall be considered as not subject to failure.

- 38.2.3.2. The '*Established Retardation Co-efficient*' of the '*Emergency Brake System*' shall be shown to be not less than 0.18 according to the requirements and limitations of clause 38.3.5 ('*Emergency Brake System*'). The '*Brakes*' force required to obtain an '*ERC*' of 0.18 shall be able to be sustained for a period not less than 15 minutes.
- 38.2.3.3. In the case of '*Semi-Trailers*', when disconnected from the '*Prime-Mover*', the failure of any structure designed to support the front of the trailer shall not reduce the effectiveness of the '*Emergency Brake System*' to less than half that required by clause 38.2.3.2.
- 38.2.3.4. '*Emergency Brake Systems*' that employ '*Stored Fluid Energy*' to hold them in the release position shall be provided with an auxiliary release mechanism that is not dependent on fluid energy provided by the tow vehicle. The auxiliary device, control or tool shall be attached to the trailer chassis rail, or equivalent structure, in an inconspicuous position forward of the forward most '*Axle*' on the rear '*Axle Group*' on the right-hand side of the trailer.
- 38.2.4. '*Parking Brake System 38/00*'
- 38.2.4.1. The '*Parking Brake System 38/00*' shall be independent of the '*Service Brake System*' except that the brakes and any mechanical system attached directly thereto may be common.
- 38.2.4.2. The '*Parking Brake System 38/00*' shall be able to be applied by means of a single '*Control*' and once applied, shall be able to be held in position by purely mechanical means. It shall not be possible to release the Parking Brake unless a means of immediately reapplying it is available. If the parking brake is held in the released position by '*Stored Fluid Energy*' the provisions of clause 38.2.3.4 shall apply. Additional parking brake facilities are permitted provided that the requirements of this clause are met.
- 38.2.4.3. The '*Parking Brake System 38/00*' shall be shown to be capable of holding the trailer stationary on an 18 percent gradient in either direction, according to the requirements of clause 38.3.6 (Parking Brake Effectiveness).

38.3. PERFORMANCE TEST REQUIREMENTS

38.3.1. Introduction

- 38.3.1.1. The trailer '*Brake System*' shall be capable of meeting the requirements of:
- (a) clause 38.3.3 - Service Brake Effectiveness (b) clause 38.3.4 - Service Brake Fade Effectiveness (c) clause 38.3.5 - '*Emergency Brake System*' (d) clause 38.3.6 - Parking Brake Effectiveness (e) clause 38.3.11 - Time Response

- 38.3.1.2. Each '*Unique*' '*Brake System*' fitted to each trailer type shall be shown to comply with clause 38.3.1.1. A trailer will be considered as being of the same type where it has the same number of '*Axles*' and '*Gross Trailer Mass*', and where no substantial change has been made to either trailer length, height, tyre size or suspension.

Trailers complying with ECE 13/05 shall be taken as meeting the requirements of this Rule so long as any '*Variable Proportioning Brake Systems*' fitted are able to be held in the '*LTM*' position and adjacent to the Trailer '*Control Line*' connectors having the words: "Ensure Load Proportioning Brake System on Trailer is HELD in LOADED POSITION if Tow Vehicle NOT Fitted with Load Proportioning".

- 38.3.1.3. Where minor changes have been made and compliance with clause 38.3.1.1 (test requirements) must be shown, compliance in relation to an '*Approved Brake System*' for a trailer type may be demonstrated by supplying the evidence needed to justify the maintenance of performance standards in the areas affected by the changes.

- 38.3.1.3.1. For example:

- (a) if an '*Approved Brake System*' were fitted to a substantially shorter '*Semi-Trailer*' the suitability of a '*Brake System*' having the same service brake effectiveness would have to be supported.
- (b) if trailer length were substantially increased, time response data might be required.
- (c) if an auxiliary '*Parking Brake System 38/00*' control were fitted, evidence would need to be provided to show that the '*Approved Brake System*' performance aspects had not been degraded.

- 38.3.1.3.2. Where '*Axle*' types are to be substituted for one another, the comparison for service brake effectiveness should be on the basis of '*Established Retardation Coefficient*'. In the case of air '*Brake Systems*' having service brake effectiveness specified as ARC, ERC may be determined by calculating K_2 in the equation below.

$$S = K_1V + \frac{V^2}{K_2}$$

where

S is stopping distance from initial movement of the '*Control*' in metres.

V is the initial velocity, in km/h

K_1 is a constant related to time delay where at a value of 0.09 is equal to a time delay of 0.32 second

K_2 is a constant related to established retardation and at a value of 115 is equivalent to 0.45 g (4.4 m/s²).

- 38.3.1.3.3. In the case of '*Brakes*' friction materials, the substitute material would have to be identical in regard to its SAE J 866a - "Friction Identification System for Brake Linings and Brake Blocks for Motor Vehicles" (September 1966) and to meet or exceed the requirements of SAE J 840c

- "Test Procedures for Brake Shoe and Lining Adhesives and Bonds" (May 1971), and SAE J 998 - "Minimum Requirements for Motor Vehicle Brake Linings" (January 1968), or other international standards.
- 38.3.1.3.4. Submissions for compliance approval based in part on a previously approved trailer shall be in relation to an approval based on a complete submission of either test or calculation data.
- 38.3.2. General Test Conditions - Road Tests
- 38.3.2.1. The ambient temperature at the test site shall be greater than 0 and less than 40°C.
- 38.3.2.2. All road tests shall be conducted with tyres fitted of the size specified by the '*Manufacturer*' as original equipment and shall be inflated to pressures not less than those recommended by the '*Manufacturer*'.
- 38.3.2.3. Braking tests shall be carried out on approximately level surfaces. Where the levels are unsurveyed, the test shall be completed in both directions, the brakes being applied over the same section, and the two results averaged to determine the final result. Where the difference in start and finish elevations for a brake test, expressed as a percentage of the stopping distance, is shown, the brake test need only be completed in one direction and the result corrected for any difference in elevation exceeding 1 percent.
- 38.3.2.4. The wind speed difference between two tests in opposite directions, or against the direction of travel in the case of a single brake test, shall not exceed 15 km/h.
- 38.3.2.5. The towing vehicle used to facilitate the tests shall be of a type normally employed to tow the particular trailer under test and shall have enough power to attain the initial speed required for the specified braking tests.
- 38.3.2.6. All road tests shall be conducted with the trailer loaded to '*MLTM*' and energy storage devices charged to '*Normal Minimum Energy Level*', unless otherwise required by this Rule.
- 38.3.2.7. The test surface shall be either concrete or bitumen pavement and shall be free from loose material.
- 38.3.2.8. No towing vehicle braking system or other contrived means shall contribute to braking effort, and the towing vehicle engine shall be declutched or neutral engaged, during the braking tests required by this Rule.
- 38.3.2.9. The '*Brakes*' shall be burnished before conducting any effectiveness tests according to the brake manufacturer's recommended procedures.
- 38.3.2.10. The '*Brake System*' shall be adjusted in accordance with the brake manufacturer's recommendations before performance tests are conducted.
- 38.3.2.11. The performance requirements shall be met with no deviation of the vehicle from its course greater than 300 millimetres.

38.3.3. Service Brake Effectiveness

38.3.3.1. Each '*Unique*' trailer '*Service Brake System*' shall be either tested in accordance with clause 38.3.2 (general test conditions) and clause 38.3.3.2 (service brake effectiveness test) or be shown by calculation, based on data for approved components, as detailed in clause 38.4.1 (service brake effectiveness calculation), to meet the requirements of clause 38.2.2.6 (refers to Figure 1).

38.3.3.2. Service Brake Effectiveness Test.

38.3.3.2.1. The initial speed at the point where trailer braking commences shall be:

- (1) for trailers having a '*Aggregate Trailer Mass*' less than 45 tonnes and not being restricted by design speed limitations, 58 to 64 km/h.
- (2) for trailers having a '*Aggregate Trailer Mass*' greater than 45 tonnes, or special trailers having a design speed less than 58 km/h, not less than the '*Manufacturer's*' nominated design speed.

38.3.3.2.2. The trailer shall be laden to '*LTM*' and braked to a stop from initial speed starting with a '*Control Signal*' of 0.2 '*E*' and in increasing increments of not greater than 0.2 '*E*' for subsequent stops until an '*Established Retardation Co-efficient*' of not less than 0.45 is achieved.

38.3.3.2.3. In the case of a compressed air '*Brake System*' the '*Control Signal*', applied to the '*Control Line*' at the front of the trailer, shall reach 65 percent of the final value in less than 0.22 second.

Where the available '*Control Signal*' is slower than 0.22 second the additional time will be allowed for entirely in clause 38.3.3.2.5 by adjusting the K_1 or K_3 term. The response of a vehicle control system should be determined by using an 800 millilitres vessel to simulate the trailer, with the pressure being measured at the point most remote from that of air entry.

38.3.3.2.4. Either stopping distance or time from the point where the trailer brake control commences actuation from the "off" position, to the point where the trailer comes to a stop, may be used to calculate the '*ERC*' according to the equations in clause 38.3.3.2.5 A calibrated decelerometer and chart recorder may also be used.

38.3.3.2.5. The '*Service Brake System*' Established Retardation Coefficient shall be determined according to the following as required:

$$ERC = \frac{0.00394V^2}{S - K_1V} \times \frac{\text{'Total Combination Mass'}}{\text{'Total Trailer Axle Load'}}$$

$$ERC = \frac{0.0283V}{T - K_3} \times \frac{\text{'Total Combination Mass'}}{\text{'Total Trailer Axle Load'}}$$

where:

V is the initial speed km/h

S is the '*Stopping Distance*' metres

T is the '*Stopping Time*' seconds

'Total Combination Mass' tonnes

'Total Trailer Axle Load' tonnes

K_1 is the time delay constant referred to in clause 38.3.1.3 and should be set at 0.09 for air *'Brake Systems'* unless it is shown that an alternative value should be used.

K_3 is the effective time delay of 0.32 seconds referred to in clause 38.3.1.3 for air *'Brake Systems'* and this value should be used unless a more appropriate value can be demonstrated.

- 38.3.3.2.6. The computed *'Established Retardation Coefficients'* determined from clause 38.3.3.2.5 shall comply with clause 38.2.2.6 (service effectiveness).
- 38.3.3.2.7. No part of the *'Brake System'* shall exceed 100°C immediately prior to the commencement of a brake test sequence.
- 38.3.3.3. No trailer wheels shall remain locked, except below approximately 10 km/h, during completion of the braking tests required by the sections of clause 38.3.3.2.
- 38.3.3.4. In the case of *'Dog Trailers'* at least one front *'Axle'* shall skid before at least one rear *'Axle'* at an *'ERC'* greater than:
- (a) 0.3 in the case of two *'Axle'* *'Dog Trailers'*;
 - (b) 0.15 in the case of *'Dog Trailers'* with three or more *'Axles'*.
- 38.3.3.4.1. The test shall be conducted generally in accordance with clause 38.3.3.2 (service brake effectiveness) with the *'Control Signal'* and surface type selected to demonstrate the requirement of clause 38.3.3.4 above.
- The initial speed requirement of clause 38.3.3.2.1 does not apply.
- 38.3.3.5. Computer simulation of the requirements of clause 38.3.3 is allowed where the simulation is sufficiently sophisticated and has been approved by the *'Administrator'* on the basis of an adequate back to back comparison with physical test results.
- 38.3.4. Service Brake Fade Effectiveness
- 38.3.4.1. Each *'Unique'* trailer *'Service Brake System'* shall be shown by either test in accordance with clause 38.3.2 (general test conditions) and clause 38.3.4.2 (service brake fade effectiveness test) or by the calculation based on data for *'Approved'* components in clause 38.4.2 (service brake fade calculation), to meet the requirements of clause 38.3.4.2.1 (degree of fade) and clause 38.2.2.5 (distribution of fade resistance).
- 38.3.4.2. Service Brake Fade Effectiveness Test
- 38.3.4.2.1. The *'Service Brake System'* shall, on the next application after not less than 20 successive applications, each not more than 60 seconds after the preceding one, of the trailer *'Brakes'* from an initial speed of 60 km/h to a final speed as calculated by clause 38.3.4.2.2, achieve a calculated *'Established Retardation Coefficient'*, when tested in accordance with clause 38.3.3.2 (service brake effectiveness test), of not less than 60 percent of the value obtained for the service brake effectiveness test

required by clause 38.3.3.2 nor less than 80 percent of the value specified by the lower bound of Figure 1.

- 38.3.4.2.2. The final speed to which the trailer has to be successively braked as part of the brake fade conditioning procedure shall be determined from the equation

$$V_1^2 - V_2^2 = 2700 \times \frac{'TGLAR'}{'Total Combination Mass'}$$

where:

V_1 is the initial speed in km/h

V_2 is the final speed in km/h

Masses and Loads in tonnes

- 38.3.4.2.3. The temperature (100°C) requirement of clause 38.3.3.2.7 shall not apply to the test required by clause 38.3.4.2.1.

38.3.5. *'Emergency Brake System'*

- 38.3.5.1. Each *'Unique'* trailer *'Emergency Brake System'* shall be shown by either test in accordance with clause 38.3.2 (general test conditions) and clause 38.3.5.2 (*'Emergency Brake System'* test) or by the calculation based on data for *'Approved'* components in clause 38.4.3 (*'Emergency Brake System'* calculation), to meet the requirements of clause 38.2.3.2 (*'Emergency Brake System'* retardation).

- 38.3.5.2. The *'Established Retardation Coefficient'*, as determined by clause 38.3.3.2.5, shall be not less than 0.18 when the *'Emergency Brake System'* is tested to the requirements of clause 38.3.3.2 (service brake effectiveness) except where clause 38.3.5.3 applies, and except that:

- (a) The *'Control Signal'* source shall be left in the "off" position with no *'Control Signal'* being provided to the trailer control line; AND
- (b) The energy level in the supply line shall be reduced to zero (in a 2-line compressed air system this will be the emergency line).

- 38.3.5.3. Where the actuation of the *'Emergency Brake System'* depends on one or more sources of *'Stored Energy'* that are common to the *'Service Brake System'*, for the purposes of testing for compliance with the requirements of clause 38.3.5.2, the trailer energy storage devices shall be charged to an energy level no greater than 0.05 *'E'* above the supply level determined for clause 38.2.1.5, or the energy storage device level if higher, at which the *'Emergency Brake System'* commences to activate the *'Brakes'*.

38.3.6. Parking Brake Effectiveness

- 38.3.6.1. Each *'Unique'* trailer *'Parking Brake System 38/00'* shall be shown by either test in accordance with clause 38.3.2 (general test conditions) or by the calculation based on data for *'Approved'* components in clause 38.4.4, to meet the requirements of clause 38.2.4.3 (parking brake effectiveness), and shall be deemed satisfactory if clause 38.3.6.1.1 or clause 38.3.6.1.2 is met.

- 38.3.6.1.1. The *'Parking Brake System 38/00'* shall be able to meet the requirements of clause 38.2.4.3 (18 percent gradient) for a 5 minute period in each direction with the force required to actuate the parking brake not exceeding 685 N in the case of a foot operated brake and not exceeding 590 N in the case of a hand operated brake. The necessary longitudinal force will be considered to have been applied if the sum of the force applied to the trailer towing point and the force due to the effect of gravity on the laden trailer mass, in the direction parallel to the test surface and trailer longitudinal axis, is greater than 0.18 times the *'Aggregate Trailer Mass'*. Where the test involves a force depending on the slope of the test surface, the slope shall not be less than 10 percent.
- When the test involves the action of slope on the trailer or combination mass, and the towing vehicle remains connected, 1.5 percent of the towing vehicle mass shall be subtracted from the other forces parallel to the test plane, to allow for rolling friction.
- The test slope shall be specified in terms of unit vertical per unit horizontal distance.
- 38.3.6.1.2. The *'Parking Brake System 38/00'* shall meet the requirements of clause 38.3.5.2 (*'Emergency Brake System'* performance) when the calculation of *'ERC'* according to clause 38.3.3.2.5 is with an *'Aggregate Trailer Mass'* instead of *'Total Trailer Axle Load'* and the *'Foundation Brakes'* geometry is such that a reversal of the required braking torque will not reduce the ability of the *'Parking Brake System 38/00'* to generate the required braking torque.
- 38.3.7. Not used
- 38.3.8. Dynamometer Test Conditions
- 38.3.8.0 Where dynamometer testing is used in lieu or in support of the requirements of the "road" testing required by clauses 38.3.2 to 38.3.7, the requirements of this clause shall apply.
- 38.3.8.1. The dynamometer inertia for each wheel shall not be less than that determined from the expression:
- $$I = MR^2$$
- where:
- I is the dynamometer inertia, in kg.m²
- M is the mass supported by the wheel at the *'GALR'* in kg.
- R is the *'Static Loaded Tyre Radius'* of the tyre, as specified by the tyre manufacturer, in metres.
- The ambient temperature shall be between 23.0 and 38.0° C.
- 38.3.8.2. Ambient air shall be directed continuously over the brake drum or disc at a velocity of not more than 11.2 m/s.
- 38.3.8.3. The temperature of each brake shall be measured by a single plug-type thermocouple installed in the centre of the lining surface of the most heavily loaded shoe or pad. The thermocouple shall be outside any centre groove.

38.3.8.4. The rate of brake drum or disc rotation on a dynamometer corresponding to the rate of rotation on a vehicle at a given speed shall be calculated by assuming a tyre radius equal to the '*Static Loaded Tyre Radius*' specified by the tyre manufacturer.

38.3.8.5. Burnishing, if conducted, shall consist of:

- (1) not more than 200 stops such that any instantaneous deceleration does not exceed 3.1 m/s^2 from a maximum speed of 65 km/h. The initial brake temperature for each stop shall be not less than 155 and not more than 200° C ;

and

- (2) not more than 200 additional stops from a maximum speed of 65 km/h at a deceleration not exceeding 3.1 m/s^2 . The initial brake temperature for each stop shall not be less than 230 and not more than 290° C .

After burnishing, the '*Brakes*' will be adjusted in accordance with the '*Manufacturer's*' recommendations.

38.3.8.6. Brake temperature shall be increased to the specified level by conducting one or more stops from not more than 65 km/h at a deceleration not exceeding 3.1 m/s^2 , or decreased to a specified level by rotating the drum or disc at a constant speed not exceeding 50 km/h.

38.3.8.7. Speeds, decelerations and time specified in clause 38.3.8 shall be achieved within the following tolerance limits:

Speeds: +5, -1 km/h

Decelerations: +0.25, -0.25 m/s^2

Times: +5, -5 seconds.

38.3.9. Service Brake Effectiveness - Dynamometer Test

38.3.9.1. The service brake effectiveness test is to be conducted with an initial brake temperature of between 50 and 95° C by conducting a series of stops from 80 km/h whilst maintaining constant brake actuator air pressure. The average torque from the time the specified air pressure is reached until the brake stops is divided by the '*Static Loaded Tyre Radius*' specified by the tyre manufacturer to determine the retardation force. The complete test procedure requires seven stops to be made, each from the specified initial temperature, with the first run pressure being 138 kPa and increasing an additional 69 kPa for each of the remaining stops.

38.3.9.2. If a comparison of '*ERC*' determined under clause 38.3.9.1 is to be made with that obtained under the road test described in clause 38.3.3 of this Rule, due allowance must be made for the effect that test speed may have on the result. A direct comparison of dynamometer data from an initial speed of 60 km/h or that derived by interpolating between a high and lower speed is acceptable.

- 38.3.10. Service Brake Fade Performance Dynamometer Test
- 38.3.10.1. When mounted on an inertia dynamometer, each brake shall be capable of making 10 consecutive decelerations at an average rate of 2.75 m/s from 80 km/h to 24 km/h at equal intervals of 72 seconds, and shall be capable of decelerating to a stop from 32 km/h at an average deceleration rate of 4.25 m/s² one minute after the 10th deceleration. The series of decelerations shall be conducted as follows.
- 38.3.10.1.1. With an initial brake temperature between 65 and 95 ° Celsius for the first brake application, and the drum or disc rotating at a speed equivalent to 80 km/h, apply the brake and decelerate at an average deceleration rate of 2.75 m/s² to 24 km/h. Upon reaching 24 km/h accelerate to 80 km/h and apply the brake for a second time 72 seconds after the start of the first application. Repeat the cycle until 10 decelerations have been made. The service line air pressure shall not exceed 690 kPa during any deceleration.
- 38.3.10.1.2. One minute after the end of the last deceleration required by clause 38.3.10.1.1 and with the drum or disc rotating at a speed of 32 km/h decelerate to a stop at an average deceleration rate of 4.25 m/s².
- 38.3.10.2. Starting 2 minutes after completing the tests required by clause 38.3.10.1 the brake shall be capable of making 20 consecutive stops from 48 km/h at an average deceleration rate of 3.65 m/s² at equal intervals of one minute measured from the start of each brake application. The service line air pressure needed to attain a rate of 3.65 m/s² shall be not more than 586 kPa and not less than 137 kPa for a brake not subject to the control of an 'Antilock System', or 82 kPa for a brake subject to the control of an 'Antilock System'.
- 38.3.11. Time Response Measurement
- 38.3.11.1. Except where hydraulic brakes are used, each 'Unique' trailer 'Brake System' shall be shown to meet the requirements of clause 38.2.2.3 (actuation time) and clause 38.2.2.4 (release time) by testing in accordance with clause 38.3.11.3 or on the basis of a calculation in accordance with clause 38.4.5 (time response calculation).
- 38.3.11.2. A variant of a 'Unique' trailer 'Brake System' will be considered to be identical in regard to time response, when the only variation from the 'Unique' 'Brake System' is one or more of the following:
- (a) Plumbing or energy transmission line lengths and number of fittings are reduced but other characteristics including diameter, material, type of connecting fittings and the characteristic transmission loss per unit length are not changed.
 - (b) Entire subsections of the 'Brake System' have been removed, as would be the case in converting a modular three 'Axle' system to a modular two 'Axle' system, such that the effect if any is to slightly increase the energy flow rate to and from the remaining brake sub-systems.
 - (c) The energy required to actuate the substitute brake actuators to their maximum design level is less.

- 38.3.11.3. Where a trailer '*Brake System*' is required to be tested for compliance with clause 38.2.2.3 and clause 38.2.2.4 in the case of compressed air '*Brake System*', the test rig described in Figure 2 shall be calibrated in accordance with clause 38.3.11.3.2 and connected as described in Figure 3.
- 38.3.11.3.1. Where a rear service coupling for towed trailers is provided, time responses shall be measured with an 800 millilitres vessel attached to the rear service coupling as in Figure 3.
- 38.3.11.3.2. The test rig described in Figure 2 shall be calibrated by adjustment of the orifice (O) such that with the storage reservoir (R1) charged to 1.0 '*E*' (650 kPa), the time between the initial pressure drop measured between the storage reservoir and the control valve (V), and the pressure at the end of the calibrating vessel (R2) increasing to 0.65 '*E*' (420 kPa), is between 0.18 and 0.22 seconds.
- 38.3.11.3.3. The test rig and the trailer energy storage devices shall be charged to 1.0 '*E*' (650 kPa) prior to the test being conducted and no additional energy shall be added to the storage vessel (R1) or the trailer '*Supply Line*' during the period of the test.
- 38.3.11.3.4. The brake actuation time shall be taken from when the pressure level, measured between the storage reservoir and the control valve, initially drops to when the pressure in the least favoured brake actuator reaches 0.65 '*E*' (420 kPa).
- 38.3.11.3.5. With an initial service brake application level of 1.0 '*E*' (650 kPa) the brake release time shall be taken from when the pressure level, measured between the control valve and the orifice, initially drops to when the pressure in the least favoured brake actuator reaches 0.05 '*E*' (35.0kPa).
- 38.3.11.3.6. The brake control valve shall be of a configuration that permits energy to flow from the storage reservoir to the orifice (O) when in the "on" position and from the orifice to waste when in the "off" position. It shall not allow additional energy to flow into the test rig '*Control Line*' by way of its own '*Control Signal*'. The brake control valve control shall be designed so that the manner of its operation shall have no effect on the output response of the test rig. The brake control valve may be arranged to provide a modulated test rig output signal for other brake development purposes but which for the purpose of measuring trailer '*Brake System*' response in accordance with clause 38.3.11.3 will be rendered inoperative.

38.4. PERFORMANCE CALCULATION REQUIREMENTS

- 38.4.1. Service Brake Effectiveness Calculation
- 38.4.1.1. Service Brake Effectiveness will be considered satisfactory if it complies with all the requirements of clause 38.4.1.
- 38.4.1.2. The distribution of braking effort amongst the '*Axles*' in an '*Axle Group*' shall be a value, or be in the range of values, referred to in clause 38.4.6.3.4 (suspension behaviour).

38.4.1.3. In the case of ‘*Dog Trailers*’ at least one front ‘*Axle*’ shall have a higher friction utilisation than that of at least one rear ‘*Axle*’ at decelerations greater than:

- (a) 0.3 g in the case of 2 ‘*Axle*’ ‘*Dog Trailers*’,
- (b) 0.15 g in the case of ‘*Dog Trailers*’ with 3 or more ‘*Axles*’.

38.4.1.3.1. In the case of two-‘*Axle*’ ‘*Dog Trailers*’ the friction utilization factors may be calculated according to

$$\text{Friction Utilisation Factor} = \frac{\text{Tangential Force at Wheel}}{\text{Dynamic Load at Wheel}}$$

so:

$$F_1 = \frac{T_1}{P_1 + \frac{zhP}{L}} \quad F_2 = \frac{T_2}{P_2 + \frac{zhP}{L}}$$

- F Friction utilization factor.
- P₁ front ‘*Axle*’ static load
- P₂ rear ‘*Axle*’ static load
- P total static ‘*Axle Load*’
- h height of trailer and load centre of mass
- L ‘*Wheel Base*’
- z deceleration, as a proportion of acceleration due to gravity.

38.4.1.3.2. No friction utilisation factor (F) shall exceed 0.7 at z = 0.45.

This is taken as to mean that wheel lock would have occurred in the physical test otherwise required by clause 38.3.3.2.2 (service brake effectiveness).

38.4.1.3.3. For ‘*Dog Trailers*’ with more than two ‘*Axles*’ where it is not practical to calculate the friction utilization factors, a skid test on a loose surface at ‘*LTM*’ to ensure that at least one front ‘*Axle*’ skids before a rear ‘*Axle*’ is sufficient evidence.

38.4.1.4. The braking ratio $\frac{\text{(Total brake force)}}{\text{(‘Total Trailer Axle Load’)}}$

of the trailer for various levels of input ‘*Control Signal*’ as determined on the basis of data provided under clause 38.4.6.1 for the ‘*Control System*’ and clause 38.4.6.2 for the ‘*Foundation Brakes*’, shall lie between the upper and lower bounds of Figure 1. e.g.

$$\frac{\text{‘Total Trailer Axle Load’}}{\text{total brake force at e}} = \frac{e \left(\frac{C_1 T_1}{R} + \frac{C_2 T_2}{R} + \dots \text{ etc} \right)}{(P_1 + P_2 + \dots \text{ etc})}$$

where :

e is values of ‘*E*’ in the range 0.2 - 1.0

C is the ratio of output to input signal strength for the '*Control System*' for the '*Axle*' concerned

T is the '*Brakes*' output torque per unit input signal to the '*Brakes*' actuator from the '*Control System*' for the '*Axle*' concerned

R is the rolling radius of the tyre on the wheel

P is the static load on the '*Axle*' concerned 1,2,etc. are subscripts referring to a particular '*Axle*'.

38.4.1.4.1. The calculated '*ERC*' corresponding to a '*Control Signal*' of 1.0 '*E*' shall be not less than 0.45.

38.4.1.5. The provisions of clause 38.3.3.5 (computer simulation allowed) also apply to clause 38.4.1 (service effectiveness calculation).

38.4.2. Service Brake Fade Calculation

The '*Service Brake System*' shall be considered to have sufficient brake fade resistance to meet the requirements of this Rule if the fade resistance of the individual axles rated according to the dynamometer test in clause 38.3.8 and clause 38.3.10, or the road fade test in clause 38.3.2 and clause 38.3.4 is greater than the requirement of clause 38.2.2.5 (distribution of effort).

38.4.3. '*Emergency Brake System*' Calculation

The '*ERC*' for the '*Emergency Brake System*' shall be determined by computing the total braking force at the wheels to which emergency brakes are fitted and dividing by the '*Total Trailer Axle Load*'

38.4.3.1. The braking force at each '*Axle*' shall be calculated according to

$$F = \frac{A \times T}{R}$$

Where

F is the tangential force at the braked wheels on the '*Axle*' concerned

A is the input to the emergency brakes actuator

T is the ratio of output torque to input signal for the emergency brakes

R is the rolling radius of the tyre fitted to the wheel.

In most cases this will be the same as for the '*Foundation Brakes*'.

38.4.3.1.1. Where the actuating force is dependent on the stroke, as in the case of spring brakes, the force used in the equation above shall be that corresponding to the stroke determined from the data provided for the '*Brake Device*' at the required actuating force. In the case of spring brakes the actuating force may be converted to an equivalent air pressure and actuator area so the units of the calculation are compatible.

38.4.3.2. The ratio of brake force to static '*Axle Load*' at each '*Axle*' must not exceed that specified in the data for the suspension as '*Approved*' under the provision of clause 38.4.6.3. Higher values correspond to wheel skid and unrealised braking potential.

- 38.4.4. Parking Brake Calculation
- 38.4.4.1. The performance of the '*Parking Brake System 38/00*' shall be determined on the basis of the characteristics of the '*Foundation Brakes*' (where applicable) provided under clause 38.4.6.2 ('*Foundation Brakes*') and the control force available at the '*Brakes*' actuator.
- 38.4.4.2. The provisions of clause 38.4.3.1.1 (spring brake force) shall apply.
- 38.4.4.3. When '*Emergency Brake System*' performance data are used to demonstrate compliance of the '*Parking Brake System 38/00*', the geometry of the '*Brakes*' shall be such that brake effectiveness will be not less in the reverse direction.
- 38.4.5. Time Response
- 38.4.5.1. The time response of a '*Brake System*' may be taken as complying with the requirements of this Rule if the '*Brake System*' is installed in a manner identical to that prescribed in the documentation describing the '*Approved*' '*Control System*' used, except as allowed in clause 38.4.5.2.
- 38.4.5.2. Actuator sizes and line lengths may be reduced to less than those specified in the '*Approved*' '*Control System*' documentation, but devices, fittings and other dimensions may not be changed without voiding approval of the '*Control System*' in regard to time response.
- 38.4.6. Specification of '*Brake System*' Components
- Sub-assemblies of '*Brake System*' components may be '*Approved*' by the '*Administrator*' as part of the '*Brake System*' approval process where information has been supplied in accordance with the requirements of this clause.
- 38.4.6.1. '*Control System*'
- 38.4.6.1.1. The '*Control System*' shall be characterised by comparing output and input signal strengths at not less than five points equally spaced over the range 0.2 '*E*' to 1.0 '*E*'.
- 38.4.6.1.2. The input signal strength shall be the final value of the signal and shall be applied to the '*Control System*' such that it rises from zero to 65 percent of the final value in not more than 0.22 second. In the case of air '*Brake System*'s' the input '*Control Signal*' strength (kPa) will be measured at the trailer '*Control Line*' coupling.
- 38.4.6.1.3. The output signal strength shall be the final value of the signal generated for control of the '*Brakes*' actuator and which shall be reached in not more than two seconds. The output signal strength (kPa) will be measured in the actuator attached to each output having a fundamentally different relation to the input. In the case of air '*Brake Systems*' a '*Control Signal*' path having additional pressure limiters, relay valves or other active devices will be considered as being fundamentally different.
- 38.4.6.1.4. Time response shall be measured where necessary in accordance with clause 38.3.11 (time response measurement). Where the '*Control System*' is not installed on an actual trailer, it shall be installed in an essentially identical manner, in the laboratory, with all bends, fittings and worst case

line lengths and representative actuator volumes installed. Actuator displacement shall be the largest volume for which the '*Control System*' is designed and it may be represented by an equivalent fixed volume.

- 38.4.6.1.5. All relevant test conditions pertaining to clause 38.3.2 (road test general conditions) shall be complied with.
- 38.4.6.1.6. The '*Control System*' to be approved shall be fully documented and the logic of its operation described and assurances provided that the '*Control System*' will meet the systems requirements of this Rule.
- 38.4.6.2. '*Foundation Brakes*'
- 38.4.6.2.1. The effectiveness of the '*Foundation Brakes*' shall be characterised by comparing the '*Control Signal*' provided to the '*Brakes*' actuator against the output brake torque of the '*Brakes*' device at not less than five points approximately equally spaced over the range 0.2 '*E*' to 1.0 '*E*'.
Parameters relevant to the specification of the '*Brakes*' actuator, and its stroke at each '*Control Signal*' level, shall be recorded. In the case of '*S-Cam*' air systems this will include the actuator size, slack adjuster length and any other special feature.
- 38.4.6.2.2. Measurements shall be taken under the conditions prescribed for the dynamometer test in clause 38.3.8 and clause 38.3.9 or in accordance with the relevant conditions for the road test described in clause 38.3.2 and clause 38.3.3.
- 38.4.6.2.3. The '*Brakes*' shall be burnished before conducting any effectiveness tests according to the brake manufacturer's recommended procedures.
- 38.4.6.2.4. Specification of effectiveness for '*Foundation Brakes*' shall be on the basis of '*Axle*' performance with two brake assemblies rather than wheel performance.
- 38.4.6.3. Suspension Behaviour
- 38.4.6.3.1. Suspensions shall be classified by the '*Administrator*' as '*Brake Reactive Suspensions*' or non '*Brake Reactive Suspensions*'.
- 38.4.6.3.2. Suspensions being determined as brake reactive shall be further specified in accordance with the remainder of clause 38.4.6.3.
- 38.4.6.3.3. The '*Skid Limit*' for each '*Axle*' as determined by the need to provide service, emergency and parking '*Brakes*' shall be determined.
It is necessary to determine the '*Skid Limit*' for each braked '*Axle*' in a group of '*Axles*' connected by a '*Brake Reactive Suspension*' to ensure that brake induced '*Axle Load*' changes do not lead to premature wheel lock-up. Note: Premature wheel skid could either be unsatisfactory in its own right (service brake effectiveness) or it could invalidate calculations based on no-skid performance (parking and emergency brake effectiveness).
- 38.4.6.3.4. For a '*Service Brake System*' '*Axle Group*' the '*Skid Limit*' value, or a range of values, at a total retardation not less than 0.45 the '*Axle Group*' load shall be determined.

The test result shall be reported as the value of the indicated retardation force for each 'Axle' divided by the greatest of the 'Axle' retardation forces.

In the case of 'S-Cam' air 'Brake Systems' the overall effect of changing actuator and slack adjuster sizes can be simulated by individually adjusting the air pressure to each 'Axle'.

- 38.4.6.3.5. For an 'Emergency Brake System' or a 'Parking Brake System 38/00' the 'Skid Limit' value shall be specified as the dimensionless ratio:

$$\frac{\text{Indicated retardation force}}{\text{Static 'Axle Load.'}}$$

The limit value should be determined by increasing the braking uniformly on all the wheels concerned until one wheel locks.

- 38.4.6.3.6. For the purpose of testing the suspension shall be installed in a typical trailer application, be fitted with 'Axles', wheels and tyres of a size appropriate to the mass rating of the suspension, and be fitted with identical calibrated 'Brakes' at each 'Axle'.

"Calibrated" in this case means that the relationship between the input 'Control Signal' and the output torque for the 'Brakes' on each 'Axle' has been measured.

'Skid limits' may be determined either dynamically or at a low speed under drag conditions, in either case at a test mass not less than one half 'GGALR'.

Note. Rigid 'Drawbar'/chassis installations will not be considered as typical of installations on 'Pig Trailers' having a pivoted 'Drawbar'.

38.5. ALTERNATIVE STANDARDS

(Refer to clause 38.3.1.2.)

Table 1

Group 'Axle Load' Limits

Number of 'Axles' in 'Axle Group'	Tyre Type "a" and Configuration	Group 'Axle Load' Limit (tonnes)
1	S	6.0
	D	9.0
	W ₁	6.7
	W ₂	7.0
2	S S	11.0
	S D	13.0
	W ₁ W ₁	13.3
	D D	16.5
	W ₂ W ₂	14
3	S S S	15
	D D D	20.0
	W ₁ W ₁ W ₁ or W ₂ W ₂ W ₂	20.0
"a": S D W ₁ W ₂	Single tyre per wheel Dual tyres per wheel 'Wide Single Tyre' (375 to 450 mm width) 'Wide Single Tyre' (over 450 mm width)	

Figure 1
Service Brake Effectiveness

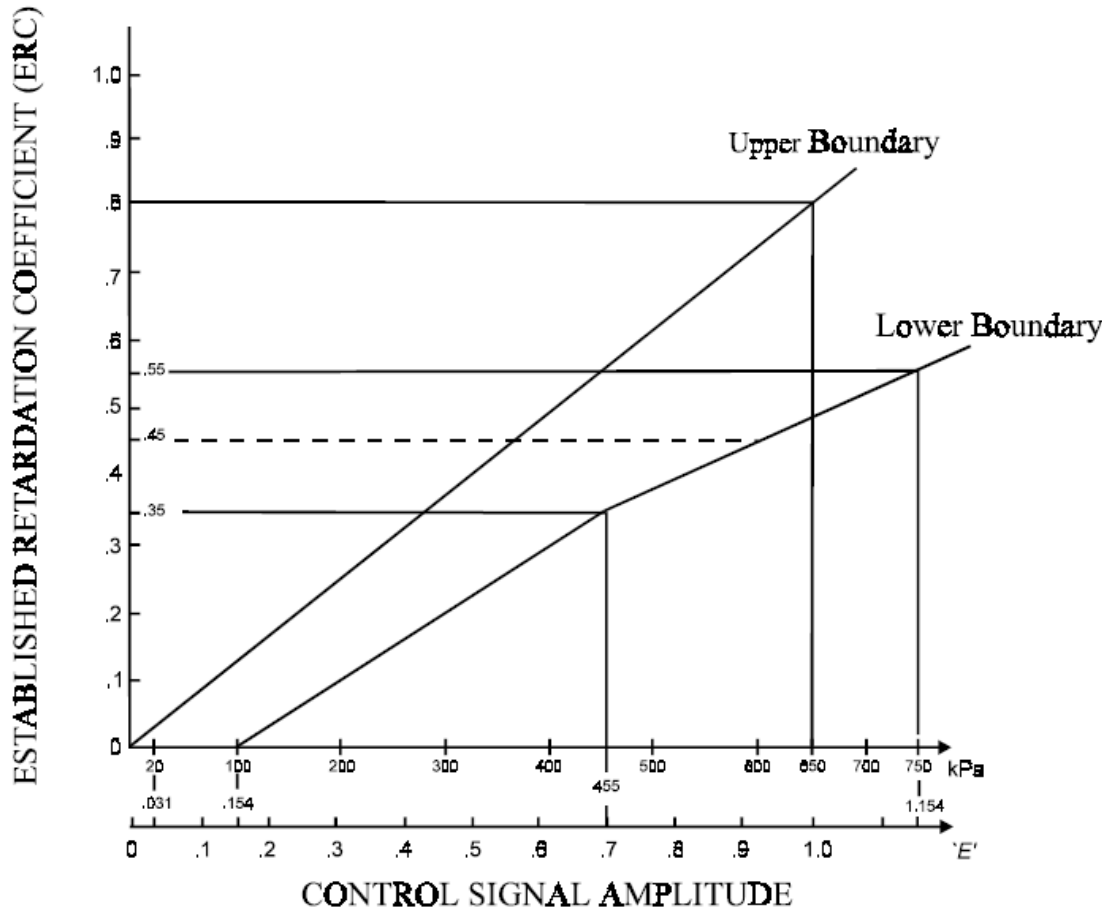

Use Of Trailer Compressed Air Brake System Test Rig

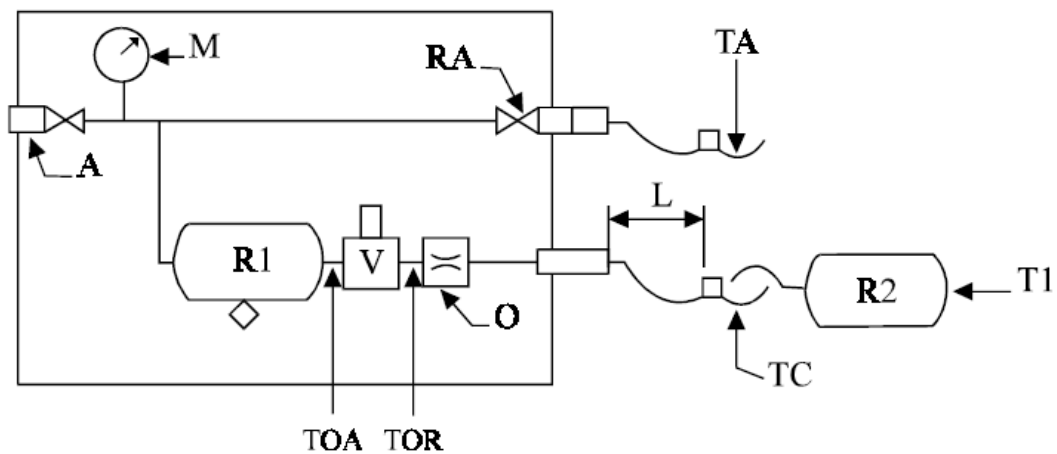

Figure 2 – Calibration of Test Rig

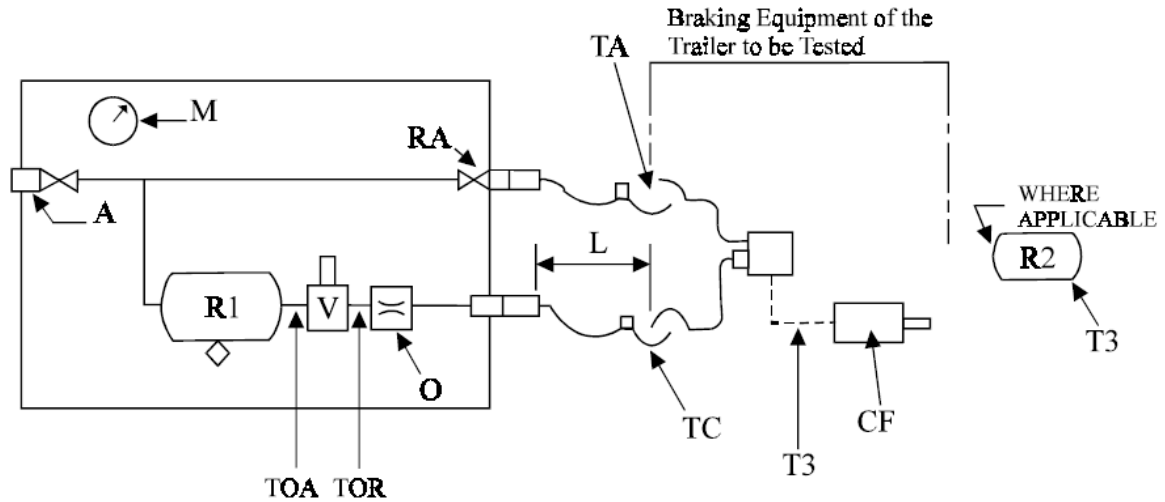

Figure 3 – Testing the Trailer

NOMENCLATURE FOR FIGURES 2 AND 3

- A = Supply connection with single check valve and regulator set at 650 kPa
- CF = trailer brake actuator
- L = coupling hose, 13 mm nominal bore and 2.5 metres long
- M = Pressure gauge
- O = orifice (see calibration note)
- R1 = reservoir of not less than 30,000 mL
- R2 = calibrating vessel of 800 5 mL
- RA = shut off valve
- TA = coupling head - supply (emergency)
- TC = coupling head - control (service)
- TOA = transducer point for timing inlet to brake actuation time
- TOR = transducer point for timing inlet to brake release time
- T1 = transducer point for calibration at end of R2 reservoir
- T3 = transducer point for testing trailer
- V = brake control valve