



Vehicle Standard (Australian Design Rule 19/01 – Installation of Lighting and Light-Signalling Devices on L-Group Vehicles) 2007

I, JAMES ERIC LLOYD, Minister for Local Government, Territories and Roads,
determine this vehicle standard under subsection 7 (1) of the *Motor Vehicle Standards
Act 1989*.

Dated 9 May 2007

[SIGNED]

James Eric Lloyd

Minister for Local Government, Territories and Roads

CONTENTS

0.	LEGISLATIVE PROVISIONS.....	3
1.	SCOPE.....	3
2.	APPLICABILITY AND IMPLEMENTATION.....	3
3.	DEFINITIONS	4
4.	REQUIREMENTS	4
5.	EXEMPTIONS AND ALTERNATIVE PROCEDURES	4
6.	SUPPLEMENTARY GENERAL REQUIREMENTS	5
7.	SUPPLEMENTARY INDIVIDUAL SPECIFICATIONS	6
8.	ADDITIONAL REQUIREMENTS	9
9.	ALTERNATIVE STANDARDS	11
10.	NOTES	11
	APPENDIX A	12

0. LEGISLATIVE PROVISIONS

- 0.1. Name of Standard
 - 0.1.1. This Standard is the Vehicle Standard (Australian Design Rule 19/01 – Installation of Lighting and Light-Signalling Devices on L-Group Vehicles) 2007.
 - 0.1.2. This Standard may also be cited as Australian Design Rule 19/01 — Installation of Lighting and Light-Signalling Devices on L-Group Vehicles.
- 0.2. Commencement
 - 0.2.1. This Standard commences on the day after it is registered.
- 0.3. Repeal
 - 0.3.1. This Standard repeals and replaces Vehicle Standard (Australian Design Rule 19/01 – Installation of Lighting and Light-Signalling Devices) 2006

1. SCOPE

This vehicle standard prescribes requirements for the number and mode of installation of lighting and light-signalling devices on L-group vehicles.

2. APPLICABILITY AND IMPLEMENTATION

- 2.1. This vehicle standard applies to the design and construction of vehicles as set out in the table below.
- 2.2. These vehicles must have their lighting and light-signalling devices installed to comply with the relevant requirements of this vehicle standard or with an acceptable prior rule as set out hereunder.
- 2.3. Where the fitment of a lamp is indicated as optional, this means that it is not mandatory to fit the lamp but, if fitted, the lamp(s) are required to comply.
- 2.4. Vehicles certified to any of the “Acceptable Prior Rules”, as shown below in the applicability table for a particular vehicle category, are deemed to comply with this rule.
- 2.5. Vehicles certified to ADR 67/... need not comply with this rule.

Applicability Table

Vehicle Category	ADR Category Code *	UNECE Category Code *	Manufactured on or After	Acceptable Prior Rules
Moped 2 wheels	LA	L1	1 Jan 1997	/00
Moped 3 wheels	LB	L2	1 Jan 1997	/00
Motor cycle	LC	L3	1 Jan 1997	
Motor cycle and sidecar	LD	L4	1 Jan 1997	
Motor tricycle	LE	L5	1 Jan 1997	/00
Passenger car	MA	M1	Not Applicable	
Forward-control passenger vehicle	MB	M1	Not Applicable	
Off-road passenger vehicle	MC	M1	Not Applicable	
Light omnibus	MD	M2	Not Applicable	
Heavy omnibus	ME	M3	Not Applicable	
Light goods vehicle	NA	N1	Not Applicable	
Medium goods vehicle	NB	N2	Not Applicable	
Heavy goods vehicle	NC	N3	Not Applicable	
Very light trailer	TA	O1	Not Applicable	
Light trailer	TB	O2	Not Applicable	
Medium trailer	TC	O3	Not Applicable	
Heavy trailer	TD	O4	Not Applicable	

3. DEFINITIONS

3.1. Refer to paragraph 2 of Appendix A.

4. REQUIREMENTS

4.1. Vehicles must comply with the requirements of this rule. Vehicles complying with the requirements of Appendix A as varied by Part 5 Exemptions and Alternative Procedures and Part 6 Supplementary General Requirements shall be accepted as complying with this rule.

5. EXEMPTIONS AND ALTERNATIVE PROCEDURES

5.1. The following provisions of Appendix A do not apply to this rule:

- Section 1 - Scope
- Section 3 - Application for approval
- Section 4 - Approval
- Section 7 - Modifications of the vehicle type or of the installation of its lighting and light signalling devices
- Section 9 - Penalties for non-conformity of production
- Section 10 - Production definitely discontinued

* The category code may also be in the format L₁, L_A etc.

Section 11 - Transitional provisions

Section 12 - Names and addresses of technical services responsible for conducting approval tests, and of administrative departments

Annexes

Annex 1 - Communication concerning the approval or refusal or extension or withdrawal of approval or production definitely discontinued of a vehicle type with regard to the installation of lighting and light signalling devices pursuant to Regulation no. 48.

Annex 2 - Arrangements of approval marks.

6. SUPPLEMENTARY GENERAL REQUIREMENTS

6.1. In addition to the lamps specified in Appendix A, the following lamps may be fitted, or where Mandatory must be fitted. When optional lamps are fitted they must comply with the requirements in this part or the requirements of part 7 or part 8 of this rule.

6.2. Mandatory Lamps

6.2.1. Reversing Lamp (clause 7.2) applicable to LB, LD and LE category vehicles only if fitted with reverse gear.

6.2.2. Conspicuity Lamps (clause 8.9) Applicable to LC and LD category vehicles only.

6.3. Optional Lamps

6.3.1. *'Search Lamp'* (clause 7.3)

6.3.2. Reversing Lamp (clause 7.2) applicable to LA and LC category vehicles only if fitted with reverse gear.

6.3.3. Front reflex reflector , non-triangular (clause 7.4)

6.3.4. Parking Lamp (clause 7.1)

6.3.5. Rear fog lamps (clause 8.8)

6.3.6. Driving lamps (clause 8.1)

6.4. The colour of light emitted by lamps referred to in this national standard must be as specified in Table 1

Table 1

LAMP	COLOUR OF EMITTED LIGHT	Component Rule
Driving Lamp	White	46/00, 55/00
Passing Lamp	White	46/00, 54/00 (mopeds). 55/00
Direction-indicator Lamp	Amber	6/00 or 53/00
Stop Lamp	Red	49/00, 53/00
Rear registration plate illuminating device	White	53/00
Front position lamp	White	49/00, 53/00
Rear position lamp	Red	49/00, 53/00
Rear retro-reflector, non-triangular	Red	47/00
Side retro-reflector, non-triangular	Amber	47/00
Vehicle-hazard warning signal	Amber	53/00 or 6/00
Front fog lamp	White or yellow	50/00
Rear fog lamp	Red	52/00
Front retro-reflector, non-triangular	Identical to incident light	47/00
Reversing Lamp (rear)	White	1/00
Internal Lamp	Any colour	None
Search Lamp	White	None
Parking Lamp (rear)	Red	49/00, 53/00 – Position lamps

7. SUPPLEMENTARY INDIVIDUAL SPECIFICATIONS

The following individual requirements are supplementary to the requirements of Appendix A.

7.1. PARKING LAMP

7.1.1. Number

7.1.2. Arrangement

Arrangement A – one at the front to ADRs 53 or 49

Arrangement B – two at the front to ADRs 53 or 49

Arrangement C - one at the rear to ADRs 53 or 49

Arrangement D – two at the rear to ADRs 53 or 49

Arrangement E – one on each side (amber to side acceptable)

7.1.2.1. For LA and LC category vehicles, if rear orientation only – arrangement C. If front and rear orientation – arrangement A and C.

7.1.2.2. For LD category vehicles, if rear orientation only – arrangement C or D and E. If front and rear orientation arrangement A, D and E or B, C and E.

7.1.3. Position

In width: on, to the right or on either side of the median longitudinal plane.

In height: not less than 350 mm nor more than 1200 mm above the ground.

In length: at the front or rear of the vehicle.

7.1.4. Geometric visibility

Horizontal angle: 45° outwards.

Vertical angle: 15° above and below the horizontal. The vertical angle below the horizontal may be reduced to 5°, if the height of the lamp is less than 750 mm

7.1.5. Orientation

7.1.5.1. May be “grouped” with any other rear lamp.

7.1.5.2. May not be “combined” with any other lamp.

7.1.5.3. May be “reciprocally incorporated” with

At the front, with any front lamp other than direction indicator lamp

At the rear, with the rear position lamp, stop lamp or a rear fog lamp.

7.1.6. Electrical connections:

The connection must allow the parking lamp to be lit independently of any other lamps. The lamp must be able to function even if the device for starting and stopping the engine is in a position which makes it impossible for the engine to operate.

7.1.7. Tell-tale

Circuit-closed tell-tale optional. If there is one, it must not be possible to confuse it with the tell-tale for the front and rear position lamps.

7.1.8. Other requirements

The functioning of this lamp may also be performed by simultaneously switching on the front and rear position lamps on the same side of the vehicle.

7.2. REVERSING LAMP

7.2.1. Number

One or two

7.2.2. Arrangement

No special requirement.

7.2.3. Position

In width: no special requirement

In height: not less than 250 mm nor more than 1200mm above the ground.

In length: at the back of the vehicle.

7.2.4. Geometric visibility

Horizontal angle: 45° to the right and left if there is only one lamp, 45° outwards and 30° inwards if there are two lamps. Vertical angle: 15° upwards and 5° downwards.

7.2.5. Orientation

Rearwards

7.2.6. Electrical Connections

The lamp must light up if the reverse gear is engaged and the engine is running. It may light up if the reverse gear is engaged and if the device which controls the starting and stopping of the engine is in such a position that operation of the engine is possible. It must not light up or remain lit if either of the above conditions is not satisfied.

7.2.7. Tell-tale

Optional

7.2.8. Other requirements

None

7.3. 'SEARCH LAMP'

7.3.1. Number

One

7.3.2. Arrangement

No special requirement

7.4. FRONT REFLEX REFLECTOR, NON-TRIANGULAR

7.4.1. Number

One or two reflectors for LA, LC and LD categories.

7.4.2. Arrangement

No special requirement

7.4.3. Position

in width: for LA, LC and LD category vehicles fitted with one reflector, the centre of reference of the reflector must be in the median longitudinal plane of the vehicle. If two reflectors are fitted, that point on the illuminating surface of the reflector which is furthest from the vehicle must not be more than 400 mm from the extreme outer edge of the side-car.

7.4.4. Geometric visibility

Horizontal angle: from 30° left to 30° right. Vertical angle: 15° above and below the horizontal. The vertical angle below the horizontal may be reduced to 5°, in the case of a reflex reflector less than 750 mm above the ground.

7.4.5. Orientation
Towards the front.

7.4.6. Other requirements
The illuminating surface of the reflex reflector may have parts in common with that of any other front lamp.

8. ADDITIONAL REQUIREMENTS

The following individual requirements are additional to the requirements set out in Appendix A.

8.1. DRIVING LAMP

8.1.1. Number
For LD category vehicles, one or two lamps

8.2. PASSING LAMP

8.2.1. Number
For LD category vehicles, one or two lamps

8.3. DIRECTION – INDICATOR LAMP

8.3.1. Arrangement:
LD category vehicles, one or two lamps

8.3.2. Operating tell-tale
The colour of the tell-tale may be yellow.

8.4. FRONT POSITION LAMP

8.4.1. Number
One or two lamps for LD categories either separate or incorporated in the passing beams. Front position lamps are optional for LC and LD category vehicles, when these vehicles are fitted with conspicuity lamps to paragraph 8.9.

8.4.2. Position
In width: For LD category vehicles, one must be mounted on the side-car so that the point on the illuminating surface which is farthest from the motor cycle shall not be more than 150 mm from the extreme outer edge of the side-car.

8.4.3. Other requirements
For LD category vehicles, the front position lamp and the rear position lamp on the side-car may be “combined” provided that the geometric visibility for each lamp is maintained.

8.5. REAR POSITION LAMP

8.5.1. Position
In width: For LD category vehicles, one lamp shall be located on the motor cycle as per paragraph 6.7.3.1 of Appendix A. The other lamp

shall be mounted on the side-car so that the point on the illuminating surface which is farthest from the motor cycle shall not be more than 150 mm from the extreme outer edge of the side-car.

8.5.2. Orientation

Additionally to paragraph 6.7.7 of Appendix A, for LD category vehicles, the rear position lamp and the front position lamp on the side-car may be “combined” provided that the geometric visibility for each lamp is maintained.

8.6. REAR REFLEX REFLECTOR, RED NON TRIANGULAR

8.6.1. Number

Two or three for LD categories (if motorcycle has two already, should not have to remove one when fitting side car).

8.6.2. Position

In width: For LD category vehicles, at least one reflector must be mounted on the motor cycle as per paragraph 6.8.3 of Appendix A. If a reflector is mounted on a side car, the points of the illuminating surface which is farthest from the motor cycle shall not be more than 400mm from the extreme outer edge of the side-car.

8.7. VEHICLE HAZARD WARNING SIGNAL

At the start of the third sentence in paragraph 6.9 of Appendix A, add “Except in the locking position”.

8.8. REAR FOG LAMP

8.8.1. Position

In width: For LD category vehicles, where only one lamp is fitted, the lamp shall be on or to the right of the median longitudinal plane of the vehicle.

8.9. CONSPICUITY LAMPS

8.9.1. Number Two to ADR 45/...

8.9.2. Arrangement No special requirement.

8.9.3. Position

8.9.3.1. In width: they shall be positioned equidistant from the median longitudinal plane of the vehicle.

8.9.3.2. In height: not less than 250 mm and not more than 1,200 mm above the ground.

8.9.3.3. In length: at the front of the vehicle. This requirement shall be deemed to be satisfied if the light emitted can not be seen by the driver either directly or indirectly through the rear vision mirror and/or other reflecting surfaces of the vehicle.

8.9.4. Geometric visibility Horizontal angle: from 80° inwards to 80° outwards. Vertical angle: 15° above and below the horizontal.

8.9.5. Orientation Forward. The lamps may move with the steering.

- 8.9.6. May be “grouped” with other front lamps.
- 8.9.7. May be “combined” with any other front lamps.
- 8.9.8. May be “reciprocally incorporated” with other front lamps other than direction indicator lamps.
- 8.9.9. Electrical Connections
- 8.9.9.1. The conspicuity lamps shall be lighted each time the engine is started but may be extinguished whenever a passing lamp or driving lamp to Appendix A of this rule is lighted.
- 8.9.9.2. The conspicuity lamps need not be lighted whenever the engine is not operating or when the device which controls the starting and stopping of the engine is in the off position.
- 8.9.10. Tell-tale No requirement.
- 8.9.11. Alternative requirements A single or twin passing lamp(s) to paragraph 6.2. of Appendix A shall be deemed to meet the requirements for conspicuity lamps provided that the passing lamp(s) meets the requirements of Clause 8.9.9.
- 8.9.12. Other Requirements None.

9. ALTERNATIVE STANDARDS

- 9.1. The technical requirements of any of the editions of United Nations – Economic Commission for Europe Regulation No. 53 – “UNIFORM PROVISIONS CONCERNING THE APPROVAL OF CATEGORY L3 VEHICLES (MOTOR CYCLES) WITH REGARD TO THE INSTALLATION OF LIGHTING AND LIGHT –SIGNALLING DEVICES ‘from the edition incorporating the 00 series of amendments up to and including the edition incorporating the 01 series of amendments are deemed to be equivalent to the technical requirements of this rule.
- 9.2. For LA category vehicles: The technical requirements of any of the editions of United Nations – Economic Commission for Europe Regulation No. 74 – “UNIFORM PROVISIONS CONCERNING THE APPROVAL OF MOPEDS WITH REGARD TO THE INSTALLATION OF LIGHTING AND LIGHT –SIGNALLING DEVICES ‘from the edition incorporating the 00 series of amendments up to and including the edition incorporating the 01 series of amendments are deemed to be equivalent to the technical requirements of this rule.

10. NOTES

- 10.1. Regulation Nos.6 and 50 in Appendix A, refer to ADRs 6/00 and 53/00

APPENDIX A

UN-ECE REGULATION NO. 53/01
UNIFORM PROVISIONS CONCERNING THE APPROVAL OF CATEGORY L3
VEHICLES (MOTOR CYCLES) WITH REGARD TO THE INSTALLATION OF
LIGHTING AND LIGHT-SIGNALLING DEVICES

Incorporating
The 01 Series of Amendments
Supplement 1 to the 01 series of amendments

Regulation No. 53

UNIFORM PROVISIONS CONCERNING THE APPROVAL OF MOTORCYCLES WITH REGARD TO THE INSTALLATION OF LIGHTING AND LIGHT-SIGNALLING DEVICES

CONTENTS

REGULATION

1. Scope
2. Definitions
3. Application for approval
4. Approval
5. General specifications
6. Individual specifications
7. Modifications of the vehicle type or of the installation of its lighting and light-signalling devices
8. Conformity of production
9. Penalties for non-conformity of production
10. Production definitely discontinued
11. Names and addresses of technical services responsible for conducting approval tests, and of administrative departments

ANNEXES

- Annex 1 Communications concerning the approval (or refusal or withdrawal of approval or production definitely discontinued) of a vehicle type with regard to the installation of lighting and light-signalling devices, pursuant to Regulation No. 53.
- Annex 2 Arrangement of approval marks
- Annex 3 Definition of the terms of paragraph 2.6. to 2.10. of this Regulation
- Annex 4 Forward visibility of red lights and rearward visibility of white lights
- Annex 5 Control of conformity of production

Regulation No. 53

“UNIFORM PROVISIONS CONCERNING THE APPROVAL OF CATEGORY L3 VEHICLES WITH REGARD TO THE INSTALLATION OF LIGHTING AND LIGHT-SIGNALLING DEVICES

1. SCOPE

This Regulation applies to the approval of two-wheeled power-driven vehicles without side-car, having a maximum design speed exceeding 50 km/h and/or a cylinder capacity exceeding 50 cm³.

2. DEFINITIONS

For the purpose of this Regulation:

- 2.1. “approval of a vehicle” means the approval of a vehicle type with regard to the number and mode of installation of the lighting and light-signalling devices;
- 2.2. “vehicle type” means a category of vehicles which do not differ from each other in such essential respects as:
 - 2.2.1. the dimensions and external shape of the vehicle;
 - 2.2.2. the number and position of the devices;
 - 2.2.3. the following shall likewise not be deemed to be “vehicles of a different type”:
 - 2.2.3.1. vehicles which differ within the meaning of paragraphs 2.2.1. and 2.2.2. above but not in such a way as to entail a change in the kind, number, position and geometric visibility of the lamps prescribed for the vehicle type in question; and
 - 2.2.3.2. vehicles on which lamps approved under one of the Regulations annexed to the 1958 Agreement, or lamps allowed in the country in which the vehicles are registered, are fitted, or are absent where their fitting is optional;
- 2.3. “transverse plane” means a vertical plane perpendicular to the median longitudinal plane of the vehicle;
- 2.4. “unladen vehicle” means a vehicle without a driver, or passenger, and unladen, but with its fuel tank full and its normal complement of tools;
- 2.5. “lamp” means a device designed to illuminate the road or to emit a light signal to other road users. Rear registration plate lamp and retro-reflectors are likewise to be regarded as lamps;
 - 2.5.1. “equivalent lamps” means lamps having the same function and authorised in the country in which the vehicle is registered; such lamps may have different characteristics from those of the lamps with which the vehicle is equipped at the time of approval, on condition that they satisfy the requirements of this Regulation;
 - 2.5.2. “independent lamps” means devices having separate illuminating surfaces, separate light sources and separate lamp bodies;

- 2.5.3. “grouped lamps” means devices having separate illuminating surfaces and separate light sources, but a common lamp body;
- 2.5.4. “combined” means devices having separate illuminating surfaces, but a common light source and a common lamp body;
- 2.5.5. “reciprocally incorporated” means devices having separate light sources or a single light source operating under different conditions (for example, optical, mechanical, electrical differences), totally or partially common illuminating surfaces and a common lamp body;
- 2.5.6. “driving beam (main-beam) headlamp” means the lamp used to illuminate the road over a long distance ahead of the vehicle;
- 2.5.7. “passing beam (dipped-beam) headlamp” means the lamp used to illuminate the road ahead of the vehicle without dazzling or causing undue discomfort to oncoming drivers and other road users;
- 2.5.8. “direction-indicator lamp” means the lamp used to indicate to other road-users that the driver intends to change direction to the right or to the left;
A direction-indicator lamp or lamps may also be used according to provisions of Regulation No. 97.
- 2.5.9. “stop lamp” means the lamp used to indicate to other road-users to the rear of the vehicle that its driver is applying the service brake;
- 2.5.10. “rear-registration-plate illuminating device” means the device used to illuminate the space reserved for the rear registration plate; such a device may consist of several optical components;
- 2.5.11. “front position lamp” means the lamp used to indicate the presence of the vehicle when viewed from the front;
- 2.5.12. “rear position lamp” means the lamp used to indicate the presence of the vehicle when viewed from the rear;
- 2.5.13. “retro-reflector” means a device used to indicate the presence of a vehicle by the reflection of light emanating from a light source not connected to the vehicle, the observer being situated near the source;
For the purpose of this Regulation, retro-reflecting number plates the following are not considered as retro-reflectors:
- 2.5.14. “hazard warning signal” means the simultaneous operation of all of a vehicle’s direction- indicator lamps to show that the vehicle temporarily constitutes a special danger to other road users;
- 2.5.15. “front fog lamp” means the lamp used to improve the illumination of the road in case of fog, snowfall, rainstorms or dust clouds;
- 2.5.16. “rear fog lamp” means the lamp used to make the vehicle more easily visible from the rear in dense fog;
- 2.6. “Light-emitting surface” of a “lighting device”, “light-signalling device” or a retroreflector means all or part of the exterior surface of the transparent material as declared in the request for approval by the manufacturer of the device on the drawing, see annex 3;
-

- 2.7. “Illuminating surface” (see annex 3);
- 2.7.1. “Illuminating surface of a lighting device” (paragraphs 2.5.6., 2.5.7. and 2.5.15.) means the orthogonal projection of the full aperture of the reflector, or in the case of headlamps with an ellipsoidal reflector of the “projection lens”, on a transverse plane. If the lighting device has no reflector, the definition of paragraph 2.7.2. shall be applied. If the light emitting surface of the lamp extends over part only of the full aperture of the reflector, then the projection of that part only is taken into account.
- In the case of a passing beam headlamp, the illuminating surface is limited by the apparent trace of the cut-off on to the lens. If the reflector and lens are adjustable relative to one another, the mean adjustment should be used;
- 2.7.2. “Illuminating surface of a light-signalling device other than a retro-reflector” (paragraphs 2.5.8., 2.5.9., 2.5.11., 2.5.12., 2.5.14. and 2.5.16.) means the orthogonal projection of the lamp in a plane perpendicular to its axis of reference and in contact with the exterior light-emitting surface of the lamp, this projection being bounded by the edges of screens situated in this plane, each allowing only 98 % of the total luminous intensity of the light to persist in the direction of the axis of reference. To determine the lower, upper and lateral limits of the illuminating surface, only screens with horizontal or vertical edges shall be used;
- 2.7.3. “Illuminating surface of a retro-reflector” (para. 2.5.13.) means the orthogonal projection of a retro-reflector in a plane perpendicular to its axis of reference and delimited by planes continuous to the outermost parts of the retro-reflector’s optical system and parallel to that axis. For the purposes of determining the lower, upper and lateral edges of the device, only horizontal and vertical planes shall be considered;
- 2.8. The “apparent surface” for a defined direction of observation means, at the request of the manufacturer or his duly accredited representative, the orthogonal projection of:
- either the boundary of the illuminating surface projected on the exterior surface of the lens (a-b),
- or the light-emitting surface (c-d), in a plane perpendicular to the direction of observation and tangential to the most exterior point of the lens (see annex 3 to this Regulation);
- 2.9. “axis of reference” (or “reference axis”) means the characteristic axis of the lamp determined by the manufacturer (of the lamp) for use as the direction of reference ($H = 0$ degrees, $V = 0$ degrees) for angles of field for photometric measurements and for installing the lamp on the vehicle;
- 2.10. “centre of reference” means the intersection of the axis of reference with the exterior light-emitting surface; it is specified by the manufacturer of the lamp;
- 2.11. “Angles of geometric visibility” means the angles which determine the field of the minimum solid angle in which the apparent surface of the lamp must be visible. That field of the solid angle is determined by the segments of the sphere of which the centre coincides with the centre of reference of the lamp
-

and the equator is parallel with the ground. These segments are determined in relation to the axis of reference. The horizontal angles beta, correspond to the longitude and the vertical angles alpha to the latitude. There must be no obstacle on the inside of the angles of geometric visibility to the propagation of light from any part of the apparent surface of the lamp observed from infinity. If measurements are taken closer to the lamp, the direction of observation must be shifted parallel to achieve the same accuracy.

On the inside of the angles of geometric visibility no account is taken of obstacles, if they were already presented when the lamp was type-approved.

If, when the lamp is installed, any part of the apparent surface of the lamp is hidden by any further parts of the vehicle, proof shall be furnished that the part of the lamp not hidden by obstacles still conforms to the photometric values prescribed for the approval of the device as an optical unit (see annex 3 of this Regulation).

Nevertheless, when the vertical angle of geometric visibility below the horizontal may be reduced to 5 degrees (lamp at less than 750 mm above the ground) the photometric field of measurements of the installed optical unit may be reduced to 5 degrees below the horizontal;

- 2.12. “extreme outer edge”, on either side of the vehicle means the plane parallel to the median longitudinal plane of the vehicle and touching the lateral extremity of the vehicle, disregarding the projection or projections
 - 2.12.1. of rear-view mirrors,
 - 2.12.2. of direction indicator lamps,
 - 2.12.3. of front and rear position lamps and retro-reflectors;
- 2.13. “over-all width” means the distance between the two vertical planes defined in paragraph 2.12. above;
- 2.14. “A single lamp” means a device or part of a device, having one function and one apparent surface in the direction of the reference axis (see paragraph 2.8. of this Regulation) and one or more light sources.

For the purpose of installation on a vehicle, a “single lamp” also means any assembly of two independent or grouped lamps, whether identical or not, having the same function, if they are installed so that the projection of their apparent surfaces in the direction of the reference axis occupies not less than 60 % of the smallest rectangle circumscribing the projections of the said apparent surfaces in the direction of the reference axis.

In such a case, each of these lamps shall, where approval is required, be approved as a type “D” lamp.

This possible combination does not apply to driving beam headlamps, passing beam headlamps and front fog lamps.

- 2.15. “distance between two lamps” which face in the same direction means the shortest distance between the two apparent surfaces in the direction of the reference axis.

Where the distance between the lamps clearly meets the requirements of the Regulation, the exact edges of apparent surfaces need not be determined;

- 2.16. “Operating tell-tale” means a visual or auditory signal (or any equivalent signal) indicating that a device has been switched on and whether or not it is operating correctly;
- 2.17. “Circuit-closed tell-tale” means a visual (or any equivalent signal) indicating that a device has been switched on, but not indicating whether or not it is operating correctly;
- 2.18. “optional lamp” means a lamp, the installation of which is left to the discretion of the manufacturer;
- 2.19. “Ground” means the surface on which the vehicle stands which should be substantially horizontal;
- 2.20. “device” means a component or combination of components used in order to perform one or several functions.

3. APPLICATION FOR APPROVAL

- 3.1. The application for approval of a vehicle type with regard to the installation of its lighting and light-signalling devices shall be submitted by the vehicle manufacturer or by his duly accredited representative.
- 3.2. It shall be accompanied by the undermentioned documents in triplicate and the following particulars:
 - 3.2.1. a description of the vehicle type with regard to the items mentioned in paragraphs 2.2.1. to 2.2.3. above; the vehicle type duly identified shall be specified;
 - 3.2.2. a list of the devices intended by the manufacturer to form the lighting and light-signalling equipment; the list may include several types of device for each function; each type shall be duly identified (national or international approval mark, if approved, name of manufacturer, etc.); in addition, the list may include in respect of each function the additional annotation “or equivalent devices”;
 - 3.2.3. a layout drawing of the lighting and light-signalling installation as a whole, showing the position of the various devices on the vehicle; and
 - 3.2.4. if necessary, in order to verify the conformity to the prescriptions of the present regulation, a layout drawing or drawings of each lamp showing the illuminating surface, as defined in paragraph 2.7.1. above, the light-emitting surface as defined in paragraph 2.6., the axis of reference as defined in paragraph 2.9. and the centre of reference as defined in paragraph 2.10. This information is not necessary in the case of the rear registration plate lamp (paragraph 2.5.10.).
 - 3.2.5. The application shall include a statement of the method used for the definition of the apparent surface (paragraph 2.8.).
- 3.3. an unladen vehicle fitted with a complete set of lighting and light-signalling equipment, as prescribed in paragraph 3.2.2. above, and representative of

the vehicle type to be approved shall be submitted to the technical service responsible for conducting approval tests.

4. APPROVAL

- 4.1. If the vehicle submitted for approval pursuant to this Regulation meets the requirements of the Regulation in respect of all the devices specified in the list, approval of that vehicle type shall be granted.
- 4.2. An approval number shall be assigned to each type approved. Its first two digits (at present 01 for the Regulation in its 01 series of amendments) shall indicate the series of amendments incorporating the most recent major technical amendments made to the Regulation at the time of issue of the approval.
- The same Contracting Party may not assign the same number to another vehicle type or to the same vehicle type submitted with equipment not specified in the list referred to in paragraph 3.2.2. above, subject to the provisions of paragraph 7 of this Regulation.
- 4.3. Notice of approval or of refusal of approval or production definitely discontinued of a vehicle type/part pursuant to this Regulation shall be communicated to the Parties to the Agreement which apply this Regulation, by means of a form conforming to the model in annex 1 to this Regulation.
- 4.4. There shall be affixed, conspicuously and in a readily accessible place specified on the approval form, to every vehicle conforming to a vehicle type approved under this Regulation an international approval mark consisting of:
- 4.4.1. a circle surrounding the letter “E” followed by the distinguishing number of country which has granted approval;^{1/}
- 4.4.2. the number of this Regulation followed by the letter “R”, a dash, and the approval number to the right of the circle prescribed in paragraph 4.4.1.
- 4.5. If the vehicle conforms to a vehicle type approved, under one or more other Regulations annexed to the Agreement, in the country which has granted approval under this Regulation, the symbol prescribed in paragraph 4.4.1. need not be repeated; in such a case the Regulation and approval numbers and the additional symbols of all the Regulations under which approval has been granted in the country which has granted approval under this Regulation shall be placed in vertical columns to the right of the symbol prescribed in paragraph 4.4.1.
- 4.6. The approval mark shall be clearly legible and be indelible.

^{1/} 1 for Germany, 2 for France, 3 for Italy, 4 for the Netherlands, 5 for Sweden, 6 for Belgium, 7 for Hungary, 8 for the Czech Republic, 9 for Spain, 10 for Yugoslavia, 11 for the United Kingdom, 12 for Austria, 13 for Luxembourg, 14 for Switzerland, 15 (vacant), 16 for Norway, 17 for Finland, 18 for Denmark, 19 for Romania, 20 for Poland and 21 for Portugal, 22 for the Russian Federation, 23 for Greece, 24 (vacant), 25 for Croatia, 26 for Slovenia, 27 for Slovakia, 28 for Belarus, 29 for Estonia, 30 (vacant), 31 for Bosnia and Herzegovina, 32-36 (vacant) and 37 for Turkey. Subsequent numbers shall be assigned to other countries in the chronological order in which they ratify or accede to the Agreement concerning the Recognition of Approval for Motor Vehicle Equipment and Parts, and the numbers thus assigned shall be communicated by the Secretary-General of the United Nations

4.7. The approval mark shall be placed close to or on the vehicle data plate affixed by the manufacturer.

4.8. Annex 2 to this Regulation gives examples of the arrangement of the approval marks.

5. GENERAL SPECIFICATIONS

5.1. The lighting and light-signalling devices shall be so fitted that in normal conditions of use, and notwithstanding the vibrations to which they may be subjected, they retain the characteristics prescribed by this Regulation and enable the vehicle to comply with the requirements of this Regulation.

In particular, it shall not be possible for the lamps to be inadvertently maladjusted.

5.2. The illuminating lamps shall be so installed that correct adjustment of their orientation can easily be carried out.

5.3. For all light-signalling devices the reference axis of the lamp when fitted to the vehicle shall be parallel to the bearing plane of the vehicle on the road; in addition, it shall be perpendicular to the median longitudinal plane of the vehicle in the case of side retro- reflectors and parallel to that plane in the case of all light-signalling devices. A tolerance of +/- 3 degrees shall be allowed in each direction. In addition, if specifications for fitting are provided by the manufacturer they shall be complied with.

5.4. In the absence of specific instructions, the height and orientation of the lamps shall be verified with the vehicle unladen and placed on a flat horizontal surface, its median longitudinal plane being vertical and the handlebars being in the position corresponding to the straight ahead movement. The tyre pressures shall be those prescribed by the manufacturer for the particular conditions of loading required in this Regulation.

5.5. In the absence of specific instructions:

5.5.1. single lamps or reflectors shall be mounted such that their centre of reference lies in the median longitudinal plane of the vehicle;

5.5.2. lamps constituting a pair and having the same function shall:

5.5.2.1. be mounted symmetrically in relation to the median longitudinal plane;

5.5.2.2. be symmetrical to one another in relation to the median longitudinal plane;

5.5.2.3. satisfy the same colorimetric requirements; and

5.5.2.4. have identical nominal photometric characteristics;

5.5.2.5. come on and go off simultaneously;

5.6. Lamps may be grouped, combined or reciprocally incorporated with one another provided that all the requirements regarding colour, position, orientation, geometric visibility, electrical connections and other requirements, if any, for each lamp are fulfilled.

5.7. The maximum height above ground shall be measured from the highest point and the minimum height from the lowest point of the apparent surface in the direction of the reference axis. For passing beam headlamps, the

minimum height from the ground shall be measured from the lowest point of the effective outlet of the optical system (e.g. reflector, lens, projection lens) independent of its utilisation.

Where the (maximum and minimum) height above the ground clearly meets the requirements of the Regulation, the exact edges of any surface need not be determined. When referring to the distance between lamps, the position, as regards width, shall be determined from the inner edges of the apparent surface in the direction of the reference axis. Where the position, as regards width, clearly meets the requirements of the Regulation, the exact edges of any surface need not be determined.

- 5.8. In the absence of specific instructions, no lamps other than direction-indicator lamps and the vehicle-hazard warning signal shall be flashing lamps.
- 5.9. No red light shall be visible towards the front and no white light shall be visible towards the rear. Compliance with this requirement shall be verified as shown hereunder (see drawing in annex 4):
 - 5.9.1. visibility of red light towards the front; a red lamp must not be directly visible to an observer moving in zone 1 of a transverse plane situated 25 m forward of the foremost point on the vehicle;
 - 5.9.2. visibility of white light towards the rear: a white lamp must not be directly visible to an observer moving in zone 2 of a transverse plane situated 25 m rearward of the rearmost point on the vehicle;
 - 5.9.3. in their respective planes, the zones 1 and 2 explored by the eye of the observer are bound:
 - 5.9.3.1. in height, by two horizontal planes 1 m and 2.2 m respectively above the ground;
 - 5.9.3.2. in width, by two vertical planes which, forming to the front and the rear respectively an angle of 15 degrees outwards from the vehicle's median longitudinal plane, pass through the point or points of contact of vertical planes parallel to the vehicle's median longitudinal plane and delimiting the vehicle's over-all width; if there are several points of contact, the foremost shall correspond to the forward plane and the rearmost to the rearward plane.
- 5.10. The electrical connections shall be such that the front position lamp or the passing beam headlamp, if there is no front position lamp, the rear position lamp and the rear registration-plate illuminating device cannot be switched on or off otherwise than simultaneously.
- 5.11. In the absence of specific instructions, the electrical connection shall be such that the driving beam headlamp, the passing beam headlamp and the fog lamp cannot be switched on unless the lamps referred to in paragraph 5.10. above are likewise switched on. This requirement need not, however, be satisfied in the case of the driving beam headlamp and passing beam headlamp where their luminous warnings consist in switching on the passing beam headlamp intermittently, at short intervals, or in switching on

the driving beam headlamp intermittently, or in switching on the passing beam headlamp and driving-beam headlamp alternately at short intervals.

5.12. Tell-tale lamps

5.12.1. Every tell-tale lamp shall be readily visible to a driver in the normal driving position.

5.12.2. Where a “circuit-closed” tell-tale is prescribed by this Regulation, it may be replaced by an “operating” tell-tale.

5.13. Colours of the lights

The colours of the lights referred to in this Regulation shall be as follows:

driving beam headlamp:	white
passing beam headlamp:	white
direction-indicator lamp:	amber
top lamp:	red
rear-registration plate lamp:	white
front position lamp:	white
rear position lamp:	red
rear retro-reflector, non-triangular:	red
side retro-reflector, non-triangular:	amber at the front amber or red at the rear
vehicle-hazard warning signal:	amber
front fog lamp:	white or enlarged selective yellow
rear fog lamp:	red

5.14. Every vehicle submitted for approval pursuant to this Regulation shall be equipped with the following lighting and light-signalling devices:

5.14.1. driving beam headlamp (paragraph 6.1.);

5.14.2. passing beam headlamp (paragraph 6.2.);

5.14.3. direction-indicator lamps (paragraph 6.3.);

5.14.4. stop lamp (paragraph 6.4.);

5.14.5. rear-registration-plate illuminating device (paragraph 6.5.);

5.14.6. front position lamp (paragraph 6.6.);

5.14.7. rear position lamp (paragraph 6.7.);

5.14.8. rear retro reflector, non-triangular (paragraph 6.8.);

5.14.9. side retro reflectors, non-triangular (paragraph 6.12.);

5.15. It may, in addition, be equipped with the following lighting and light-signalling devices;

5.15.1. vehicle-hazard warning signal (paragraph 6.9.);

- 5.15.2. fog lamps;
- 5.15.2.1. front (paragraph 6.10.);
- 5.15.2.2. rear (paragraph 6.11.);
- 5.16. The fitting of each of the lighting and light-signalling devices mentioned in paragraphs 5.14. and 5.15. above shall be effected in conformity with the relevant requirements in paragraph 6 of this Regulation.
- 5.17. The fitting of any lighting and light-signalling devices other than those mentioned in paragraphs 5.14. and 5.15. is prohibited for the purposes of type approval.
- 5.18. Lighting and light-signalling devices type-approved for four-wheeled vehicles of categories M1 and N1 and referred to in sections 5.14. and 5.15. may also be fitted to motorcycles.

6. INDIVIDUAL SPECIFICATIONS

6.1. DRIVING BEAM HEADLAMP

6.1.1. Number

One or two.

6.1.2. Arrangement

No special requirement.

6.1.3. Position

6.1.3.1. Width

6.1.3.1.1. an independent driving lamp may be fitted above or below or to one side of another front lamp: if these lamps are on top of the other the reference centre of the driving lamp must be located within the median longitudinal plane of the vehicle; if these lamps are side by side their reference centre must be symmetrical in relation to the median longitudinal plane of the vehicle.

6.1.3.1.2. a driving lamp that is reciprocally incorporated with another front lamp must be fitted in such a way that its reference centre lies within the median longitudinal plane of the vehicle; however, when the vehicle is also fitted with an independent passing lamp alongside the driving lamp their reference centres must be symmetrical in relation to the median longitudinal plane of the vehicle.

6.1.3.1.3. two driving lamps of which either one or both are reciprocally incorporated with another front lamp must be fitted in such a way that their reference centres are symmetrical in relation to the median longitudinal plane of the vehicle.

6.1.3.2. The length: at the front of the vehicle. This requirement is regarded as satisfied if the light emitted does not cause discomfort to the driver either directly or indirectly by means of the rear-view mirrors and/or reflective surfaces on the vehicle.

- 6.1.3.3. In any case, the distance between the edge of the illumination surface of any independent driving lamp and the edge of that of the passing lamp must not exceed 200 mm.
- 6.1.3.4. In the case of two driving lamps: the distance separating the illuminating surfaces of two driving lamps must not exceed 200mm.”
- 6.1.4. Geometric visibility
The visibility of the illuminating surface, including its visibility in areas which do not appear to be illuminated in the direction of observation considered, shall be ensured within a divergent space defined by generating lines based on the perimeter of the illuminating surface and forming an angle of not less than 5 degrees with the axis of reference of the headlamp.
- 6.1.5. Orientation
Forwards. The lamp(s) may move with the steering angle.
- 6.1.6. May not be “combined” with any other lamp.
- 6.1.7. Electrical connections
The passing beam(s) may remain illuminated with the driving beam(s).
- 6.1.8. “Circuit-closed” tell-tale
Mandatory, non-flashing blue signal lamp.
- 6.1.9. Other requirements
Aggregate maximum intensity of the driving beam headlamps which can be switched on simultaneously shall not exceed 225,000 cd. (The approval value).
- 6.2. PASSING BEAM HEADLAMP
- 6.2.1. Number
One or two.
- 6.2.2. Arrangement
No special requirement.
- 6.2.3. Position
- 6.2.3.1. Width
- 6.2.3.1.1. an independent passing lamp may be installed above, below or to one side of another front lamp: if these lamps are one above the other the reference centre of the passing lamp must be located within the median longitudinal plane of the vehicle; if these lamps are side by side their reference centre must be symmetrical in relation to the median longitudinal plane of the vehicle.
- 6.2.3.1.2. a passing lamp that is reciprocally incorporated with another front lamp must be installed in such a way that its reference centre lies within the median longitudinal plane of the vehicle. However, when the vehicle is also fitted with an independent driving lamp alongside the passing lamp their
-

reference centres must be symmetrical in relation to the median longitudinal plan of the vehicle.

- 6.2.3.1.3. two passing lamps, of which either one or both are reciprocally incorporated with another front lamp must be installed in such a way that their reference centres are symmetrical in relation to the median longitudinal plane of the vehicle.
- 6.2.3.2. Height: a minimum of 500mm and a maximum of 1,200mm above the ground.
- 6.2.3.3. Length: at the front of the vehicle. This requirement is regarded as satisfied if the light emitted does not cause discomfort to the driver either directly or indirectly by means of the rear-view mirrors and/or reflective surfaces of the vehicle.
- 6.2.3.4. In the case of two passing lamps the distance separating the illuminating surfaces must not exceed 200 mm.”

6.2.4. Geometric visibility

Defined by angles alpha and beta as specified in paragraph 2.11

alpha = 15 degrees upwards and 10 degrees downwards;

beta = 45 degrees to the left and to the right for a single lamp;

beta = 45 degrees outwards and 10 degrees inwards for each pair of lamps.

The presence of partitions or other items of equipment near the head-lamp shall not give rise to secondary effects causing discomfort to other road users.

6.2.5. Orientation

6.2.5.1. Forwards. The lamp(s) may move in line with the steering angle.

6.2.5.2. The vertical orientation of the passing beam shall remain between - 0.5 % and - 2.5 % of downward inclination for the conditions of loading “vehicle plus driver”^{2/} and “manufacturer’s maximum permitted load”, the load being distributed in accordance with the manufacturer’s specification for loading and for the adjustment of the suspension (if any) for these conditions of loading.

6.2.5.3. The reference orientation corresponding to the “vehicle plus driver” shall be set between - 1 % and - 1.5 %. This pre-determined reference value shall be indicated on a plate on each vehicle.

6.2.5.4. If necessary, the vehicle shall be equipped with a device by means of which the orientation of the passing beam can be easily aligned for the load states mentioned in paragraph 6.2.5.2. above, without the need of tools.

6.2.6. May not be “combined” with any other lamp.

6.2.7. Electrical connections

The control for changing over to the passing beam(s) shall switch off the driving beam(s) simultaneously.

^{2/} Driver: a simulated mass of 75 kg +/- 1 kg.

6.2.8. Tell-tale
Optional; non-flashing green signal lamp.

6.2.9. Other requirements
None.

6.3. DIRECTION-INDICATOR LAMP

6.3.1. Number
Two per side.

6.3.2. Arrangement
Two front indicators (category 1 as specified in Regulation No. 6 or category 11 specified in Regulation No. 50).
Two rear indicators (category 2 as specified in Regulation No. 6 or category 12 specified in Regulation No. 50).

6.3.3. Position

6.3.3.1. in width: For front indicators, the following requirements shall all be met:

1. there shall be a minimum distance of 240 mm between illuminating surfaces,
2. the indicators shall be situated outside the longitudinal vertical plane tangential to the outer edges of the illuminating surface of the headlamp(s),
3. there shall be a minimum distance between the illuminating surface of the indicators and passing beam headlamp closest to one another as follows:

Minimum Indicator intensity (cd)	Minimum Separation (mm)
90	75
175	40
250	20
400	≤20

For rear indicators, the clearance between the inner edges of the two illuminating surfaces shall be at least 180 mm on the condition that the prescriptions of paragraph 2.11. are applied even when the registration plate is mounted;

6.3.3.2. in height: not less than 350 mm nor more than 1,200 mm above the ground;

6.3.3.3. in length: the forward distance between the centre reference of the rear indicators and the transverse plane which constitutes the rearmost limit of the vehicle's over-all length shall not exceed 300 mm.

- 6.3.4. Geometric visibility
Horizontal angles: 20 degrees inwards, 80 degrees outwards
Vertical angles; 15 degrees above and below the horizontal.
The vertical angle below the horizontal may be reduced to 5 degrees ,
however, if the height of the lamps is less than 750 mm.
- 6.3.5. Orientation
The front direction indicators may move in line with the steering angle.
- 6.3.6. May not be “combined” with any other lamp.
- 6.3.7. May not be “reciprocally incorporated” with any other lamp.
- 6.3.8. Electrical connections
Direction-indicator lamps shall switch on independently of the other lamps.
All direction-indicator lamps on one side of a vehicle shall be switched on
and off by means of one control.
- 6.3.9. “Operating” tell-tale
Mandatory. This may be optical or auditory or both. If it is optical it shall be
(a) flashing green lamp(s), which, in the event of defective operation of any
of the direction indicators, is extinguished, remains alight without flashing,
or shows a marked change of frequency.
- 6.3.10. Other requirements
The characteristics indicated below shall be measured with no other load on
the electrical system than that required for the operation of the engine and
the lighting devices. For all vehicles:
- 6.3.10.1. the light flashing frequency shall be 90 +/- 30 times per minute;
- 6.3.10.2. the flashing of the direction indicators on the same side of the vehicle may
occur synchronously or alternately;
- 6.3.10.3. operation of the light-signal control shall be followed within not more than
one second by the appearance of the light and within not more than one-and-
one half seconds by the first extinction of the light.
- 6.3.10.4. In the event of failure, other than a short circuit, of one direction indicator
lamp, the other(s) direction indicator lamp(s) indicating the same direction
must continue to flash or remain alight, but the frequency in this condition
may be different from that prescribed.
- 6.4. STOP LAMP
- 6.4.1. Number
One or two.
- 6.4.2. Arrangement
No special requirement.
- 6.4.3. Position
- 6.4.3.1. in height: not less than 250 mm nor more than 1,500 mm above the ground;
-

- 6.4.3.2. in length: at the rear of the vehicle.
- 6.4.4. Geometric visibility
 - Horizontal angle: 45 degrees to left and to right for a single lamp;
45 degrees outwards and 10 degrees inwards for each pair of lamps;
 - Vertical angle: 15 degrees above and below the horizontal.
 - The vertical angle below the horizontal may be reduced to 5 degrees ,
however, if the height of the lamp is less than 750 mm.
- 6.4.5. Orientation
 - Towards the rear of the vehicle.
- 6.4.6. Electrical connections
 - Shall light up at any service brake application.
- 6.4.7. “Circuit-closed” tell-tale prohibited.
- 6.4.8. Other requirements
 - None.
- 6.5. REAR-REGISTRATION-PLATE ILLUMINATING DEVICE.
 - 6.5.1. Number
 - One. The device may consist of several optical components designed to
illuminate the space reserved for the registration plate.
 - 6.5.2. Arrangement
 - Such that the device illuminates the space reserved for the registration plate.
 - 6.5.3. Position
 - Such that the device illuminates the space reserved for the registration plate.
 - 6.5.3.1. in width:
 - Such that the device illuminates the space reserved for the registration plate.
 - 6.5.3.2. in height:
 - Such that the device illuminates the space reserved for the registration plate.
 - 6.5.3.3. in length:
 - Such that the device illuminates the space reserved for the registration plate.
 - 6.5.4. Geometric visibility
 - Such that the device illuminates the space reserved for the registration plate.
 - 6.5.5. Orientation
 - Such that the device illuminates the space reserved for the registration plate.
 - 6.5.6. Tell-tale
 - Optional: Its function shall be performed by the tell-tale prescribed for the
position lamp.

6.5.7. Other requirements

When the rear registration plate lamp is combined with the rear position lamp, reciprocally incorporated in the stop lamp or in the rear fog lamp, the photometric characteristics of the rear registration plate lamp may be modified during the illumination of the stop lamp or the rear fog lamp.

6.6. FRONT POSITION LAMP

6.6.1. Number

One or two.

6.6.2. Arrangement

No special requirement.

6.6.3. Position

6.6.3.1. in height: not less than 350 mm nor more than 1,200 mm above the ground.

6.6.3.2. in length: at the front of the vehicle.

6.6.4. Geometric visibility

Horizontal angle: 80 degrees to left and to right for a single lamp: the horizontal angle may be 80 degrees outwards and 45 degrees inwards for each pair of lamps:

Vertical angle: 15 degrees above and below the horizontal. The vertical angle below the horizontal may be reduced to 5 degrees, however, if the height of the lamp is less than 750 mm.

6.6.5. Orientation

Forwards. The lamp(s) may move in line with the steering angle.

6.6.6. “Circuit-closed” tell-tale

Mandatory. Non-flashing green signal lamp. This tell-tale shall not be required if the instrument illumination lighting can be switched on or off only simultaneously with the position lamp(s).

6.6.7. Other requirements

None.

6.7. REAR POSITION LAMP

6.7.1. Number

One or two.

6.7.2. Arrangement

No special requirements.

6.7.3. Position

6.7.3.1. in height: not less than 250 mm nor more than 1,500 mm above the ground;

6.7.3.2. in length: at the rear of the vehicle.

- 6.7.4. Geometric visibility
Horizontal angle: 80 degrees to left and to right for a single lamp: the horizontal angle may be 80 degrees outwards and 45 degrees inwards for each pair of lamps:
Vertical angle: 15 degrees above and below the horizontal. The vertical angle below the horizontal may be reduced to 5 degrees , however, if the height of the lamp is less than 750 mm.
- 6.7.5. Orientation
Rearwards.
- 6.7.6. “Circuit-closed” tell-tale
Optional: Its function shall be performed by the device prescribed for the front position lamp.
- 6.7.7. Other requirements
None.
- 6.8. REAR RETRO-REFLECTOR, NON-TRIANGULAR
- 6.8.1. Number
One or two.
- 6.8.2. Arrangement
No special requirement.
- 6.8.3. Position
in height: not less than 250 mm nor more than 900 mm above the ground;
- 6.8.4. Geometric visibility
Horizontal angle: 30 degrees to left and to right for a single reflector;
30 degrees outwards and 10 degrees inwards for each pair of reflectors;
Vertical angle: 15 degrees above and below the horizontal. The vertical angle below the horizontal may be reduced to 5 degrees , however, if the height of the lamp is less than 750 mm.
- 6.8.5. Orientation
Rearwards.
- 6.9. VEHICLE-HAZARD WARNING SIGNAL
- 6.9.1. The signal shall be given by simultaneous operation of the direction-indicator lamps in accordance with the requirements of paragraph 6.3 above.
- 6.9.2. Electrical connections The signal shall be given by means of a separate control enabling all the direction indicators to be supplied with current simultaneously.
- 6.9.3. “Circuit-closed” tell-tale
Mandatory. Flashing red signal lamp or, in the case of separate tell-tales, the simultaneous operation of the tell-tale prescribed in paragraph 6.3.10.
-

6.9.4. Other requirements

Light flashing 90 +/- 30 times per minute.

Operation of the lamp-signal control shall be followed within not more than one second by the appearance of the light and within not more than one-and-one-half seconds by the first extinction of the light. The vehicle-hazard warning signal shall remain capable of being actuated even when the device which controls the starting and stopping of the engine is in such a position that operation of the engine is impossible.

6.10. FRONT FOG LAMP

6.10.1. Number

One or two.

6.10.2. Arrangement

No special requirement.

6.10.3. Position

6.10.3.1. in width: for a single lamp the centre of reference shall be in the median longitudinal plane of the vehicle; or the edge of the illuminating surface which is nearest to that plane shall be not more than 250 mm away from it;

6.10.3.2. in height: not less than 250 mm above the ground. No point on the illuminating surface shall be higher than the highest point on the illuminating surface of the passing beam headlamp.

6.10.3.3. in length: at the front of the vehicle. This requirement shall be deemed to be satisfied if the light emitted does not cause discomfort to the driver either directly, or indirectly through the rear-view mirrors and/or other reflecting surfaces of the vehicle.

6.10.4. Geometric visibility

Defined by angles alpha and beta as specified in paragraph 2.11.:

alpha upwards and downwards;

beta = 45 degrees to left and to right for a single lamp, except for an off-centre light, in which case the inward angle beta = 10 degrees ;

beta = 45 degrees outwards and 10 degrees inwards for each pair of lamps

6.10.5. Orientation

Forwards. The lamp(s) may move in line with the steering angle.

6.10.6. May not be combined with any other front lamp.

6.10.7. "Circuit-closed" tell-tale

Optional; non-flashing green signal.

6.10.8. Other requirements

None.

- 6.10.9. Electrical connections
It shall be possible to switch the fog lamp(s) on or off independently of the driving beam headlamp(s) and/or passing beam headlamp(s).
- 6.11. REAR FOG LAMP
- 6.11.1. Number
One or two.
- 6.11.2. Arrangement
No special requirement.
- 6.11.3. Position
- 6.11.3.1. in height: not less than 250 mm nor more than 900 mm above the ground;
- 6.11.3.2. in length at the rear of the vehicle.
- 6.11.3.3. the distance between the illuminating surface of the rear fog lamp and that of the stop lamp shall not be less than 100 mm.
- 6.11.4. Geometric visibility
Defined by angles alpha and beta as specified in paragraph 2.11.:
alpha = 5 degrees upwards and downwards;
beta = 25 degrees to left and to right for a single lamp 25 degrees outwards and 10 degrees inwards for each pair of lamps.
- 6.11.5. Orientation
Rearwards.
- 6.11.6. Electrical connections
They shall be such that the rear fog lamp can light up only when one or more of the following lamps are switched on: driving beam headlamp, passing beam headlamp, front fog lamp.
If there is a front fog lamp, it shall be possible to switch off the rear fog lamp independently of the front fog lamp.
The rear fog lamp(s) may continue to operate until the position lamps are switched off and they shall remain off until deliberately switched on again.
- 6.11.7. “Circuit-closed” tell-tale
Mandatory. Non-flashing amber signal lamp.
- 6.11.8. Other requirements
None.
- 6.12. SIDE RETRO-REFLECTOR, NON-TRIANGULAR
- 6.12.1. Number per side
One or two.
- 6.12.2. Arrangement
No special requirement.
-

- 6.12.3. Position
 - 6.12.3.1. on the side of the vehicle.
 - 6.12.3.2. in height: not less than 300 mm nor more than 900 mm above the ground;
 - 6.12.3.3. in length: should be placed in such a position that under normal conditions it may not be masked by the driver's or passenger's clothes.
- 6.12.4. Geometric visibility
 - Horizontal angles $\beta = 30$ degrees to the front and to the rear.
 - Vertical angles $\alpha = 15$ degrees above and below the horizontal.
 - The vertical angle below the horizontal may be reduced to 5 degrees , however, if the height of the retro-reflector is less than 750 mm.
- 6.12.5. Orientation
 - The reference axis of the retro-reflectors must be perpendicular to the vehicle's median longitudinal plane and directed outwards. The front side retro-reflectors may move with the steering angle.

7. MODIFICATIONS OF THE VEHICLE TYPE OR OF THE INSTALLATION OF ITS LIGHTING AND LIGHT-SIGNALLING DEVICES

- 7.1. Every modification of the vehicle type, or of the installation of its lighting or light-signalling devices, or of the list referred to in paragraph 3.2.2. above, shall be notified to the administrative department which approved that vehicle type. The department may then either;
 - 7.1.1. consider that the modification made are unlikely to have appreciable adverse effects and that in any case the vehicle still complies with the requirements; or
 - 7.1.2. require a further test report from the technical service responsible for conducting tests
- 7.2. Confirmation or refusal of approval, specifying the alternatives, shall be communicated by the procedure specified in paragraph 4.3. above to the Parties to the Agreement which apply this Regulation.
- 7.3. The competent authority issuing the extension of approval shall assign a series number for such an extension and inform thereof the other Parties to the 1958 Agreement applying this Regulation by means of a communication form conforming to the model in annex 1 to this Regulation.

8. CONFORMITY OF PRODUCTION

- The conformity of production procedures shall comply with those set out in the Agreement, Appendix 2 (E/ECE/324-E/ECE/TRANS/505/Rev.2), with the following requirements:
 - 8.1. Motorcycles approved under this Regulation shall be so manufactured as to conform to the type approved, by meeting the requirements set out in paragraphs 5 and 6 above.

8.2. The minimum requirements for conformity of production control procedures set forth in annex 5 to this Regulation shall be complied with.

8.3. The authority which has granted type approval may at any time verify the conformity control methods applied in each production facility. The normal frequency of these verifications shall be once a year.

9. PENALTIES FOR NON-CONFORMITY OF PRODUCTION

9.1. The approval granted in respect of a vehicle type pursuant to this Regulation may be withdrawn if the requirement laid down in paragraph 8.1. above is not met or if the vehicle has failed to pass the checks prescribed in paragraph 8 above.

9.2. If a Party to the Agreement which applies this Regulation withdraws an approval it has previously granted, it shall forthwith so notify the other Contracting Parties to the Agreement which apply this Regulation by means of a communication form conforming to the model in annex 1 to this Regulation.

10. PRODUCTION DEFINITELY DISCONTINUED

If the holder of an approval completely ceases to manufacture a vehicle type approved in accordance with this Regulation, he shall so inform the authority which granted the approval. Upon receiving the relevant communication that authority shall inform thereof the other Parties to the Agreement applying this Regulation, by means of a communication form conforming to the model in annex 1 to this Regulation.

11. TRANSITIONAL PROVISIONS

11.1. As from the official date of entry into force of the 01 series of amendments, no Contracting Party applying this Regulation shall refuse to grant approvals under this Regulation as amended by the 01 series of amendments.

11.2. As from 24 months after the date of entry into force mentioned in paragraph 11.1 above, Contracting Parties applying this Regulation shall grant approvals only if the vehicle type with regard to the number and mode of installation of the lighting and light- signalling devices corresponds to the requirements of the 01 series of amendments to this Regulation.

11.3. Existing approvals granted under this Regulation before the date mentioned in paragraph 11.2 above shall remain valid. In the case of vehicles first registered more than four years after the date of entry into force mentioned in paragraph 11.1. above

Contracting Parties applying this Regulation may refuse the vehicle type with regard to the number and mode of installation of the lighting and light- signalling devices which do not meet the requirements of the 01 series of amendments to this Regulation.

**12. NAMES AND ADDRESSES OF TECHNICAL SERVICES
RESPONSIBLE FOR CONDUCTING APPROVAL TESTS, AND OF
ADMINISTRATIVE DEPARTMENTS**

The Parties to the 1958 Agreement which apply this Regulation shall communicate to the United Nations secretariat the names and addresses of the technical services responsible for conducting approval tests and of the administrative departments which grant approval and to which forms certifying approval, extension or refusal or withdrawal of approval, issued, in other countries, are to be sent.

Annex 1

(Maximum format: A4 (210 x 297 mm))

COMMUNICATION

issued by: Name of administration:



.....
.....
.....

concerning:^{2/} APPROVAL GRANTED
APPROVAL EXTENDED
APPROVAL REFUSED
APPROVAL WITHDRAWN
PRODUCTION DEFINITELY DISCONTINUED

of a type of a category L2 vehicle with regard to the installation of lighting and light-signalling devices, pursuant to Regulation No. 53.

Approval No. Extension No.

1. Trade name or mark of the vehicle:.....
2. Manufacturer's name for the type of vehicle:.....
3. Manufacturer's name and address:.....
4. If applicable, name and address of the manufacturer's representative:.....
5. Submitted for approval on:.....
6. Technical service responsible for conducting approval tests:.....
7. Date of test report:.....
8. Number of test report:.....
9. Concise description:.....

Lighting devices on the vehicle:

- 9.1. Driving lamps: yes/no^{2/},
- 9.2. Passing lamps: yes/no^{2/},
- 9.3. Front fog lamps: yes/no^{2/},
- 9.4. -

^{1/} Distinguishing number of the country which has granted/extended/ refused/withdrawn approval (see approval provisions in the Regulation)

^{2/} Strike out what does not apply.

- 9.5. Direction indicators: yes/no ^{2/},
- 9.6. -
- 9.7. Repeating side direction indicators: yes/no ^{1/2}
- 9.8. Hazard warning signal: yes/no ^{2/},
- 9.9. Stop lamps: yes/no ^{2/},
- 9.10. Rear-registration-plate illuminating device: yes/no ^{2/},
- 9.11. Front position (side) lamps: yes/no ^{2/},
- 9.12. Rear position (side) lamps: yes/no ^{2/},
- 9.13. Rear fog lamps: yes/no ^{2/},
- 9.14. -
- 9.15. -
- 9.16. Rear reflex reflectors, non-triangular: yes/no ^{2/},
- 9.17. -
- 9.18. -
- 9.19. Side reflex reflectors, non-triangular: yes/no ^{2/},
- 9.20. Equivalent lamps: yes/no ^{2/},
- 10. Any comments.....
- 11. Position of the approval mark.....
- 12. Reason(s) for extension (if applicable):.....
- 13. Approval granted/refused/extended/withdrawn:2/
- 14. Place:.....
- 15. Date:.....
- 16. Signature:.....
- 17. The list of documents deposited with the Administrative Service which has granted the approval is annexed to this communication and may be obtained upon request.....

Annex 2

ARRANGEMENT OF APPROVAL MARKS

Model A

Model A of the approval mark, in the figure amend the number “002439” to read “012439” and in the caption below the figure, the words “Regulation No. 53 in its original form” to read “Regulation No. 53, as amended by the 01 series of amendments”.

(See paragraph 4.4. of this Regulation)

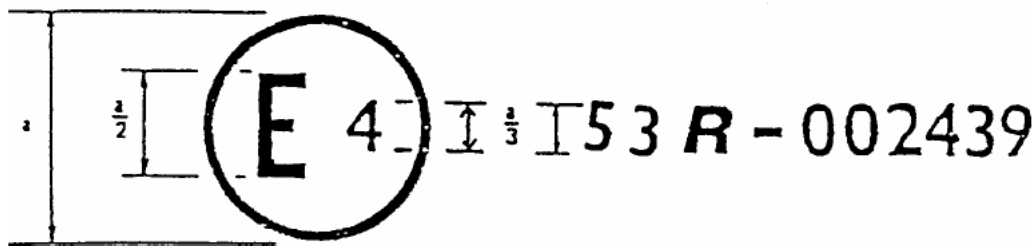

a = 8 mm min.

The approval mark affixed to a motorcycle shows that the vehicle type concerned has, with regard to the installation of lighting and light-signalling devices, been approved in the Netherlands (E4) pursuant to Regulation No. 53 in its original form. The approval number indicates that the approval was granted in accordance with the requirements of Regulation No. 53.

Model B

Model B of the approval mark, in the figure amend the number “002439” to read “012439” and the number “33” to read “78”.

(See paragraph 4.5. of this Regulation)

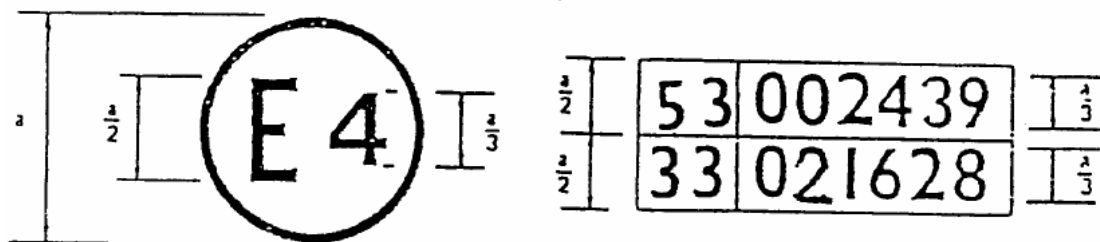

a = 8 mm min.

The above approval mark affixed to a motor cycle shows that the vehicle type concerned has been approved in the Netherlands (E4) pursuant to Regulations Nos. 53, and 78.^{1/} The approval numbers indicate that, at the dates when the respective approvals were given, Regulation No. 53 included the 01 series of amendments and Regulation No. 78 already included the 02 series of amendments.

^{1/} The latter is given merely as an example.

Annex 3

LAMP SURFACES, AXIS AND CENTRE OF REFERENCE, AND ANGLES OF GEOMETRIC VISIBILITY

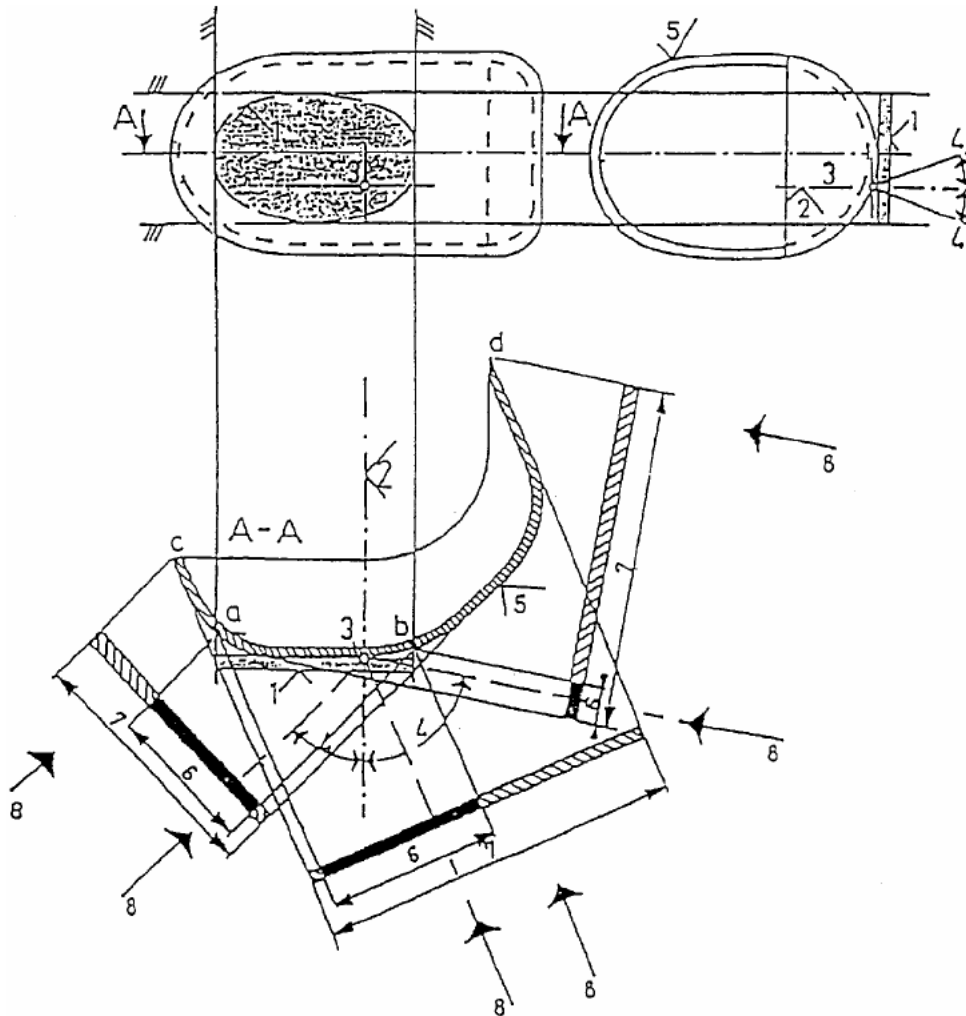

KEY

1. Illuminating surface
2. Axis of reference
3. Centre of reference
4. Angle of geometric visibility
5. Light-emitting surface
6. Apparent surface based on illuminating surface
7. Apparent surface based on light-emitting surface
8. Direction of visibility

Note:

Notwithstanding the drawing the apparent surface is to be considered as tangent to the light-emitting surface.

Annex 4

FORWARD VISIBILITY OF RED LIGHTS AND REARWARD VISIBILITY OF WHITE LIGHTS

(See paragraph 5.9. of this Regulation)

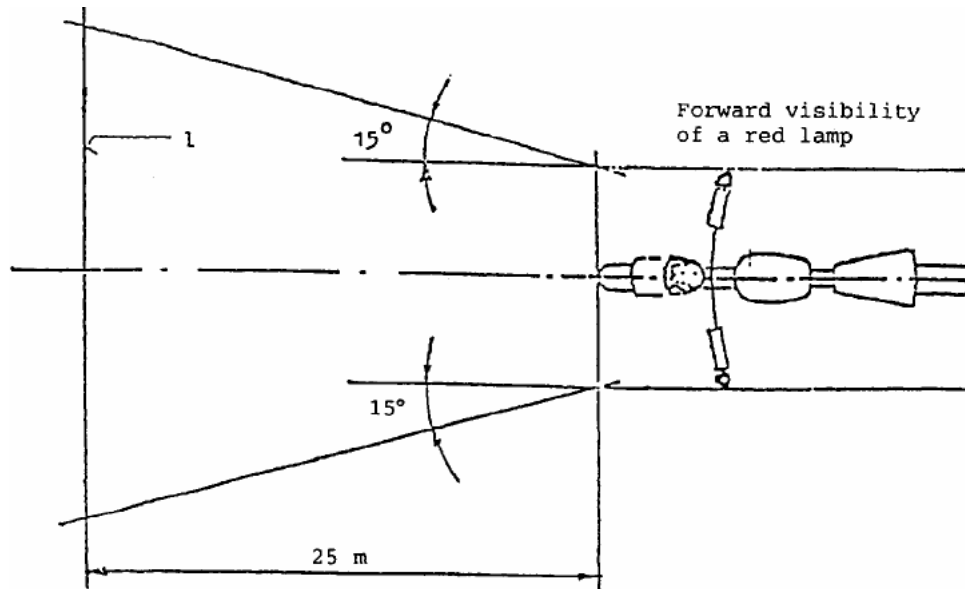

Figure 1

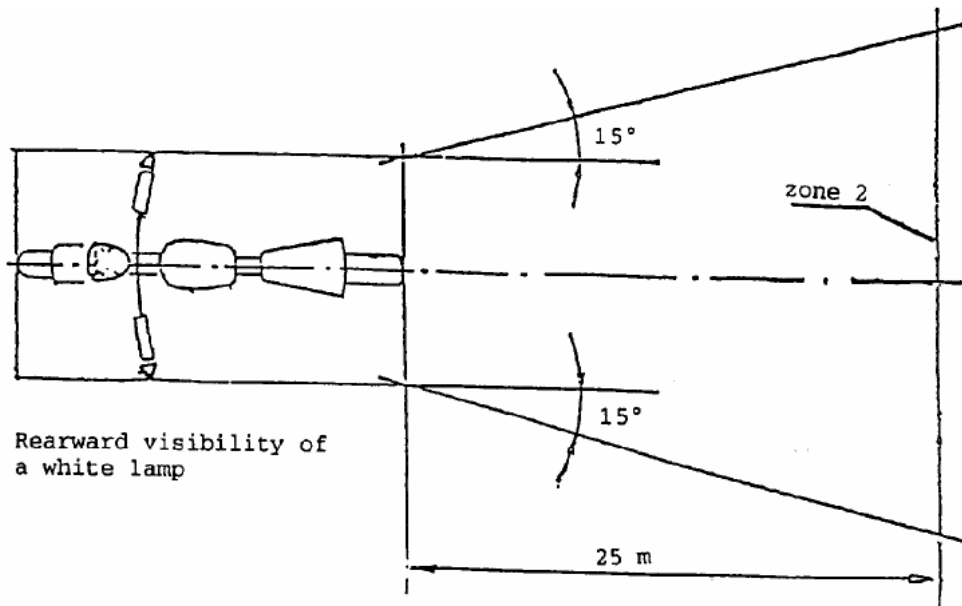

Figure 2

Annex 5

CONTROL OF CONFORMITY OF PRODUCTION

1. TESTS

1.1. Position of lamps

The position of the lamps as specified in paragraph 6 shall be checked in accordance with the general requirements set out in paragraph 5 of this Regulation. The values measured for the distances shall be such that the individual specifications applicable to each lamp are fulfilled.

1.2. Visibility of lamps

1.2.1. The angles of geometric visibility shall be checked in accordance with paragraph 2.11. of this Regulation. The values measured for the angles shall be such that the individual specifications applicable to each lamp are fulfilled except that the limits of the angles may have an allowance corresponding to the +/- 3 degrees variation permitted in paragraph 5.3. for the mounting of the light-signalling devices.

1.2.2. The visibility of red light towards the front and of white light towards the rear shall be checked in accordance with paragraph 5.9. of this Regulation.

1.3. Alignment of passing beam headlamps towards the front

1.3.1. Initial downward inclination

(The initial downward inclination of the cut-off of the passing beam shall be checked against the requirements of paragraph 6.2.5.).

1.4. Electrical connections and tell-tales

The electrical connections shall be checked by switching on every lamp supplied by the electrical system of the motorcycle. The lamps and tell-tales shall function in accordance with the provisions set out in paragraphs 5.10., to 5.12. of this Regulation and with the individual specifications, applicable to each lamp.

1.5. Light intensities

1.5.1. Driving beam headlamps

The aggregate maximum intensity of the driving beam headlamp(s) shall be such that the requirement in paragraph 6.1.9. of this Regulation is fulfilled.

1.6. The presence, number, colour, arrangement and, where applicable, the category of lamps shall be checked by visual inspection of the lamps and their markings. These shall be such that the requirements set out in paragraph 5.13. and the individual specifications applicable to each lamp are fulfilled.