



Vehicle Standard (Australian Design Rule 38/03 – Trailer Brake Systems) 2007

I, JAMES ERIC LLOYD, Minister for Local Government, Territories and Roads,
determine this vehicle standard under subsection 7 (1) of the *Motor Vehicle Standards
Act 1989*.

Dated 29th June 2007

[SIGNED]

James Eric Lloyd

Minister for Local Government, Territories and Roads

CONTENTS

0.	LEGISLATIVE PROVISIONS.....	3
1.	SCOPE.....	3
2.	APPLICABILITY AND IMPLEMENTATION.....	3
3.	DEFINITIONS	5
4.	DESIGN REQUIREMENTS FOR TRAILERS UP TO 4.5 TONNES ‘ATM’ ..	5
5.	GENERAL DESIGN REQUIREMENTS FOR TRAILERS OVER 4.5 TONNES ‘ATM’	5
6.	SERVICE BRAKE SYSTEM.....	8
7.	EMERGENCY BRAKE SYSTEM.....	9
8.	PARKING BRAKE SYSTEM.....	10
9.	GENERAL PERFORMANCE ROAD TEST CONDITIONS	10
10.	SERVICE BRAKE EFFECTIVENESS TEST CONDITIONS.....	11
11.	DOG TRAILER FRICTION UTILISATION.....	13
12.	SERVICE BRAKE FADE EFFECTIVENESS TEST.....	13
13.	EMERGENCY BRAKE SYSTEM EFFECTIVENESS TEST	13
14.	PARKING BRAKE EFFECTIVENESS TEST	14
15.	TIME RESPONSE MEASUREMENT.....	14
16.	SERVICE BRAKE EFFECTIVENESS CALCULATION	16
17.	SERVICE BRAKE FADE CALCULATION.....	17
18.	EMERGENCY BRAKE SYSTEM CALCULATION.	17
19.	PARKING BRAKE CALCULATION	18
20.	TIME RESPONSE	19
21.	SPECIFICATION OF BRAKE SYSTEM COMPONENTS.....	19
22.	ALTERNATIVE STANDARDS	22
	APPENDIX 1	28
	APPENDIX 2	30

0. LEGISLATIVE PROVISIONS**0.1. NAME OF STANDARD**

0.1.1. This Standard is the Vehicle Standard (Australian Design Rule 38/03 – Trailer Brake Systems) 2007.

0.1.2. This Standard may also be cited as Australian Design Rule 38/03 — Trailer Brake Systems.

0.2. COMMENCEMENT

0.2.1. This Standard commences on the day after it is registered.

1. SCOPE

1.1. This vehicle standard specifies requirements for braking under both normal and emergency conditions.

1.2. Compliance must be demonstrated by means of procedures outlined in the national standard for road testing and/or calculations based on data for 'Approved' components.

2. APPLICABILITY AND IMPLEMENTATION

This vehicle standard applies to the design and construction of vehicles from the dates set out in clauses 2.1, 2.2 and the table below (except those trailers designed for use behind a drawing vehicle with a maximum speed less than 50 km/h).

2.1. 1 January 2009 on all new model vehicles.

2.2. 1 July 2009 on all vehicles.

2.3. For the purposes of clause 2.1 a "new model" is a vehicle model first produced with a 'Date of manufacture' on or after the agreed date in clause 2.1.

2.4. Applicability Table

Vehicle Category	ADR Category Code *	UNECE Category Code *	Manufactured on or After	Acceptable Prior Rules
Moped 2 wheels	LA	L1	not applicable	
Moped 3 wheels	LB	L2	not applicable	
Motor cycle	LC	L3	not applicable	
Motor cycle and sidecar	LD	L4	not applicable	
Motor tricycle	LE	L5		
	LEM		not applicable	
	LEP		not applicable	
	LEG		not applicable	
Passenger car	MA	M1	not applicable	
Forward-control passenger vehicle	MB	M1	not applicable	
Off-road passenger vehicle	MC	M1	not applicable	
Light omnibus	MD	M2	not applicable	
up to 3.5 tonnes 'GVM' and up to 12 seats	MD1			
up to 3.5 tonnes 'GVM' and more than 12 seats	MD2			
over 3.5 tonnes and up to 4.5 tonnes 'GVM'	MD3			
over 4.5 tonnes and up to 5 tonnes 'GVM'	MD4			
Heavy omnibus	ME	M3	not applicable	
Light goods vehicle	NA	N1	not applicable	
Medium goods vehicle	NB	N2	not applicable	
over 3.5 tonnes up to 4.5 tonnes 'GVM'	NB1			
over 4.5 tonnes up to 12 tonnes 'GVM'	NB2			
Heavy goods vehicle	NC	N3	not applicable	
Very light trailer	TA	O1	not applicable	
Light trailer	TB	O2	1 January 2009**	see clause 22.3
Medium trailer	TC	O3	1 January 2009**	see clause 22.3
Heavy trailer	TD	O4	1 January 2009**	see clause 22.3

** See clauses 2.1 to 2.3

* UN ECE Vehicle Categories are provided for information and as reference only. The category code may also be in the format L₁, L_A etc.

3. DEFINITIONS

- 3.1. For vehicle categories, definitions and meanings used in this standard, refer to Vehicle Standard (Australian Design Rule Definitions and Vehicle Categories) 2005.

4. DESIGN REQUIREMENTS FOR TRAILERS UP TO 4.5 TONNES 'ATM'

- 4.1. Every trailer must be equipped with an efficient '*Service Brake System*' which, with the exception of trailers equipped with an '*Over-run Braking System*', must be designed so that the braking force can be progressively increased and decreased by means of the '*Control Signal*' from the towing vehicle.
- 4.2. In the case of trailers with a '*Gross Trailer Mass*' of greater than 2 tonne, the '*Brake System*' must operate on all wheels.
- 4.3. The '*Brake System*' on trailers with a '*Gross Trailer Mass*' up to 2 tonnes may be actuated for both '*Service Brake System*' and '*Secondary Brake System*' by the over-run of the trailer.
- 4.4. Every trailer having a '*Gross Trailer Mass*' over 2 tonnes must be equipped with an efficient '*Emergency Brake System*' which will cause immediate automatic application of its '*Brakes*' in the event of the trailer accidentally becoming disconnected from the drawing vehicle. '*Brakes*' so applied must remain applied for at least 15 minutes.
- 4.5. Trailers up to 4.5 tonnes '*ATM*' are not required to comply with other clauses of this rule.

5. GENERAL DESIGN REQUIREMENTS FOR TRAILERS OVER 4.5 TONNES 'ATM'

- 5.1. A '*Service Brake System*' must be fitted to all trailer wheels and be in accordance with the requirements of part 6.
- 5.2. The trailer '*Brake System*' must be capable of being actuated from the towing vehicle by means of a connection between the trailer and towing vehicle with a performance not less than that specified for the '*Emergency Brake System*' in part 7 after any one failure in a '*Brake Device*' in the trailer '*Brake System*'.
- 5.3. A '*Parking Brake System 38/...*' must be fitted and must meet the requirements of part 8.
- 5.4. The trailer '*Brake System*' must restrain the trailer automatically in the event of a trailer break-away with a performance not less than that specified for the '*Emergency Brake System*' in part 7.

- 5.5. A *'Brake System'* which utilises *'Stored Energy'* to actuate the *'Service Brake System'* must be designed so that when the *'Supply Line'* energy level is reduced at a rate of not less than 0.15E/sec (100 kPa/sec) the following conditions are met;
- 5.5.1. the *'Brake System'* must not start to automatically apply the *'Brakes'* at a *'Supply Line'* energy level of more than 0.65 *'E'* (420 kPa) and,
- 5.5.2. the *'Brake System'* must start to automatically apply the *'Brakes'* at a *'Supply Line'* energy level not less than:
- 5.5.2.1. 0.31 *'E'* (200 kPa) where the maximum braking effectiveness of the *'Brakes'* so applied is dependent on *'Stored Fluid Energy'* or;
- 5.5.2.2. 0.24 *'E'* (155 kPa) where the maximum braking effectiveness of the *'Brakes'* so applied is not dependent on *'Stored Fluid Energy'* and;
- 5.5.2.3. with the *'Supply Line'* energy level at 0.0 *'E'* the braking effectiveness must be at least that specified for the *'Emergency Brake System'* in clause 7.1.
- 5.6. The *'Brake System'* must be designed so that no single failure in a *'Brake Device'* in the *'Service Brake System'*, except of a *'Supply Line'* or *'Control Line'*, shall cause the *'Brakes'* to apply without a *'Control Signal'* provided by the towing vehicle.
- 5.7. Manual devices for the isolation of faulty devices or brake circuits may be included in the *'Brake System'* but automatic devices of the type that normally remain passive and whose function cannot readily be checked during normal operation of the trailer are not permitted. For the purposes of this clause normal operation also includes the activity of coupling and uncoupling the trailer connections.
- 5.8. Where a trailer is fitted with an auxiliary park brake release device, enabling stored energy actuation or release of any part of the *'Brake System'* to be cut out, the device must be such that the *'Brake System'* is restored to normal no later than on the resumption of the supply of *'Stored Energy'* to the trailer from the towing vehicle.
- 5.9. All components and devices in the *'Brake System'* must meet or exceed at least one appropriate and recognised international, national or association standard, where such standards exist, or the relevant parts thereof. *'Recognised'* can be taken to include SA, SAE, BS, JIS, DIN, ISO and ECE standards.
- 5.10. Brake line couplings must not be interchangeable and must be polarised. Couplings must comply with the requirements – AS 4495:2000, *'Commercial road vehicle – Interchangeable quick release couplings for use with air-pressure braking systems'* where applicable or compatible couplings which meet the requirements of ISO 1728:2006 *'Road vehicles*

- Pneumatic Braking connections between motor vehicles and towed vehicles – Interchangeability’ may be used.
- 5.11. Each air reservoir in a compressed air ‘*Brake System*’ must be fitted with a manual condensate drain valve at the lowest point. An automatic condensate valve may be fitted provided it also drains the lowest point. The manual drain valve may be incorporated in the automatic valve.
- 5.12. Each ‘*Brake System*’ must incorporate devices which compensate for any increased movement of its components arising from wear. Such devices must themselves contain provision for securing them throughout their working range in any position to which they may be adjusted to or to which they may themselves automatically adjust.
- 5.13. Except for braking systems capable of producing asymmetric braking in response to prevailing tractive conditions, each ‘*Brake System*’ must, when applied, produce a resultant braking force acting along the longitudinal centre line of the vehicle.
- 5.14. Where the ‘*Supply Line*’ supplies energy to devices other than ‘*Brake Power Unit 35/...*’ including spring brakes, the design must be such that all the ‘*Brake Power Unit 35/...*’ are preferentially charged until the supply line reaches an energy level of not less than 0.69 ‘*E*’ (450 kpa); or
- 5.14.1. the spring brakes must not release before there is sufficient pressure in the service air tank to allow application of a service brake to at least the emergency ERC as required by clause 7.1.
- 5.14.2. Systems that utilize spring brakes for emergency and parking brakes are deemed to comply with this requirement if the parking/emergency brakes do not release until a service tank pressure of 0.435 ‘*E*’ (283 kPa) is reached .
- 5.14.3. Spring brake release is deemed to occur when the brake friction materials cease to contact.
- 5.15. The first call on the ‘*Stored Energy*’ must be that of the ‘*Brake System*’. Any other demand for ‘*Stored Energy*’ must be disconnected automatically if the ‘*Stored Energy*’ level falls below 0.69 ‘*E*’ (450 kPa).
- 5.16. Where separate methods of actuation are provided for any of the functions of the ‘*Brake System*’, the actuation of one function must not cause the operation of another function.
- 5.17. ‘*Stored Energy*’ devices must be safeguarded to prevent depletion of the ‘*Stored Fluid Energy*’ through failure of any part of the supplying system.
- 5.18. In the case of a compressed air ‘*Brake system*’, a pressure test connection complying with clause 4 of ISO Standard 3583-1984 must be fitted at either the inlet to, or in the body of, the brake chamber with the slowest

reaction time in each '*Axle Group*' (in respect of brake timing as specified in part 15).

- 5.19. Where a '*Retractable Axle*' is fitted, a vehicle has a number of '*Configurations*'. It must be demonstrated by physical testing or by calculation as described in the appropriate sections of this rule that in each '*Configuration*', the vehicle complies with the laden condition requirements of this rule for that '*Configuration*'. The laden condition for '*Configurations*' with the '*Axle*' retracted must be considered to be when the '*Axle Group*' is laden to the '*Prescribed Transition Mass*' for the '*Configuration*' being considered. As the vehicle must automatically change its '*Configuration*' at the '*Prescribed Transition Mass*' by lowering an '*Axle*', for the purpose of demonstrating compliance with the requirements of this clause, the automatic system for lowering the axle may be rendered inoperative.
- 5.19.1. The requirements of clause 5.19 do not apply to:
- 5.19.1.1. the '*Service Brake System*' compatibility requirements as described in clause 6.5.1. This requirement must only be demonstrated in the conditions as specified in clause 9.6; or
- 5.19.1.2. the service Brake Actuation Time Test as described in clause 15.1
- 5.19.2. When determining the Park Brake Effectiveness either by test as in part 14 or by calculation as in part 19, the '*Aggregate Trailer Mass*' is to be multiplied by the ratio of the '*Prescribed Transition Mass*' for each '*Configuration*' divided by the '*Group Gross Axle Load Rating*'.
- 5.19.3. When determining the Emergency Brake Effectiveness either by test as in part 13 or by calculation as in part 18, the '*Gross Trailer Mass*' is to be multiplied by the ratio of the '*Prescribed Transition Mass*' for each '*Configuration*' divided by the '*Group Gross Axle Load Rating*'.

6. SERVICE BRAKE SYSTEM

- 6.1. The '*Service Brake System*' must be designed so that the braking force can be progressively increased and decreased by means of the '*Control Signal*' from the towing vehicle.
- 6.2. The combined total energy capacity of energy storage devices incorporated into the '*Service Brake System*' must be not less than 8 times the combined maximum energy capacity of the service brakes actuating devices. In the case of compressed air '*Braking Systems*', the ratio of air reservoir volume to actuator volume will be taken as being the ratio of energy capacity.
- 6.3. The elapsed time, as measured in accordance with the procedure specified in part 15 for measuring brake actuation time response must not exceed in the case of:

-
- 6.3.1. any brake actuator of any ‘*Axle Group*’ on the trailer, 0.4 seconds; and
- 6.3.2. any trailer or dolly rear service coupling for towed trailers, 0.4 seconds.
- 6.4. In the case of trailers, other than ‘*Pig Trailers*’ that are not ‘*Converter Dollies*’, designed for use in ‘*Road Trains*’ having a ‘*Gross Combination Mass*’ not exceeding 125 tonnes, the elapsed time as measured in accordance with the procedure specified in part 15 for measuring brake release time must not exceed, in the case of:
- 6.4.1. any, trailer or dolly, rear service coupling for towed trailers, 0.65 seconds.
- 6.5. Each ‘*Unique*’ trailer ‘*Service Brake System*’ must be either tested in accordance with parts 9 and 10 or be shown by calculation, based on data for approved components, as detailed in part 16 to have ‘*Established Retardation Coefficients*’ between the upper and lower boundaries of:
- 6.5.1. Figure 1, when fully laden; and
- 6.5.2. For trailers fitted with a ‘*Variable Proportioning Brake System*’, Figure 2 when at ‘*UTM*’; and
- 6.5.3. For trailers fitted with a ‘*Variable Proportioning Brake System*’, progressively between Figure 2 and Figure 1. ‘*Established Retardation Coefficients*’ may be determined by calculation for intermediate states of load between ‘*UTM*’ and fully laden. The calculations must include not less than 5 points and include any critical point.
- 6.6. Each ‘*Unique*’ trailer ‘*Service Brake System*’ must be shown by either test in accordance with parts 9 and 12 or by the calculation based on data for ‘*Approved*’ components in part 17, to meet the requirements of clause 12.1.
- 6.7. Where the ‘*Service Brake System*’ incorporates an ‘*Antilock System*’ the requirements of APPENDIX 1 must be met.
- 6.8. Trailers fitted with a ‘*Variable Proportioning Brake System*’ must have markings affixed in a visible position on the trailer in indelible form and containing the following information:
- 6.8.1. Where the ‘*Variable Proportioning Brake System*’ consists of a device mechanically controlled by the suspension of the trailer, the useful travel (recommended units of mm) of the device between the positions corresponding to ‘*UTM*’ and ‘*GTM*’, as well as any further information to enable the setting of the device to be checked in service.
- 6.8.2. Where the ‘*Variable Proportioning Brake System*’ consists of a device which modulates the air pressure in the brake transmission, the ‘*Axle*’ load(s) (recommended units of kg) corresponding to the ‘*UTM*’ and ‘*GTM*’ for the ‘*Axle(s)*’ which control(s) the device and the corresponding nominal inlet and outlet pressures (recommended units of
-

kPa) of the device, as well as any further information to enable the setting of the device to be checked in service. The inlet pressure must be not less than 80 per cent of the maximum design inlet pressure, as declared by the trailer manufacturer.

- 6.8.3. Where the '*Variable Proportioning Brake System*' consists of a device controlled via the suspension of the trailer by any other means, any information to enable the setting of the device to be checked in service.
- 6.9. Examples of markings that are in accordance with clause 6.8 for mechanically controlled devices and air pressure controlled devices in trailers fitted with a compressed air '*Brake System*' are shown in APPENDIX 2.

7. EMERGENCY BRAKE SYSTEM

- 7.1. Each '*Unique*' trailer '*Emergency Brake System*' must be shown by either test in accordance with part 9 and clause 13.1 or by the calculation based on data for '*Approved*' components in part 18, to have an '*Established Retardation Co-efficient*' of not less than 0.18 and to be able to sustain a '*Brake*' force required to obtain an '*ERC*' of 0.18 for a period not less than 15 minutes.
- 7.2. The '*Emergency Brake System*' may utilise parts of the '*Service Brake System*' on the condition that any one failure of a '*Brake Device*' in the '*Service Brake System*' does not prevent the '*Emergency Brake System*' from achieving its performance requirement. For the purpose of this clause, the '*Brakes*' and any mechanical linkage connected directly thereto, must be considered as not subject to failure.
- 7.3. In the case of '*Semi-Trailers*', when disconnected from the '*Prime-Mover*', the failure of any structure designed to support the front of the trailer must not reduce the effectiveness of the '*Emergency Brake System*' to less than half that required by clause 7.1.
- 7.4. '*Emergency Brake Systems*' that employ '*Stored Fluid Energy*' to hold them in the release position must be provided with an auxiliary release mechanism. The auxiliary device, control or tool, may rely on fluid energy stored within the trailer brake system, and must be attached to the trailer chassis rail, or equivalent structure, forward of the forward most '*Axle*' on the rear '*Axle Group*' on the right hand side of the trailer.
- 7.4.1. If the auxiliary device utilises stored energy then, with the energy storage devices initially charged to '*1.0 E*' the release system must have sufficient reserve to provide at least 3 applications and releases of the "Emergency Brake system" when the towing vehicle is disconnected.

8. PARKING BRAKE SYSTEM

- 8.1. The *'Parking Brake System 38/...'* must be independent of the *'Service Brake System'* except that the brakes and any mechanical system attached directly thereto may be common.
- 8.2. The *'Parking Brake System 38/...'* must be able to be applied by means of a single *'Control'* and once applied, must be able to be held in position by purely mechanical means.
- 8.3. It must not be possible to release the Parking Brake unless a means of immediately reapplying it is available.
- 8.4. The parking brake must operate when the *'Supply Line'* energy level drops below 0.24 'E' (155 kpa). The provisions of clause 8.3 do not apply to the auxiliary release mechanism required by clause 7.4 but the other provisions of clause 7.4 must apply.
- 8.5. Additional parking brake facilities are permitted provided that the requirements of clauses 8.2, 8.3 and 8.4 are met.
- 8.6. Each *'Unique'* trailer *'Parking Brake System 38/...'* must be shown to be capable of holding the trailer stationary on an 18 percent gradient in either direction by either:
- 8.6.1. test in accordance with part 9 and clause 14.1; or
- 8.6.2. test in accordance with part 9 and clause 14.2; or
- 8.6.3. calculation based on data for *'Approved'* components in part 19.

9. GENERAL PERFORMANCE ROAD TEST CONDITIONS

- 9.1. The ambient temperature at the test site must be greater than 0°C and less than 40°C.
- 9.2. All road tests must be conducted with tyres fitted of the size specified by the *'Manufacturer'* as original equipment and must be inflated to pressures not less than those recommended by the *'Manufacturer'*.
- 9.3. Braking tests must be carried out on approximately level surfaces.
- 9.3.1. Where the levels are unsurveyed, the test must be completed in both directions, the brakes being applied over the same section, and the two results averaged to determine the final result.
- 9.3.2. Where the difference in start and finish elevations for a brake test, expressed as a percentage of the *'Stopping Distance'*, is known, the brake test need only be completed in one direction and the result corrected for any difference in elevation exceeding 1 percent.
- 9.4. The wind speed difference between two tests in opposite directions, or against the direction of travel in the case of a single brake test, must not exceed 15 km/h.

- 9.5. The towing vehicle used to facilitate the tests must be of a type normally employed to tow the particular trailer under test and must have enough power to attain the initial speed required for the specified braking tests.
- 9.6. All road tests must be conducted with energy storage devices charged to '*Nominal Minimum Energy Level*' and the '*Axle Groups*' loaded to the following, unless otherwise required by this rule:
- 9.6.1. For trailers not fitted with a '*Variable Proportioning Brake System*', at '*GTM*' and in a separate test to the values allowed by Table 1 if this results in a trailer mass lower than '*GTM*'.
- 9.6.2. For trailers fitted with a '*Variable Proportioning Brake System*', at '*GTM*' and in a separate test to the '*UTM*'.
- 9.7. The test surface must be either concrete or bitumen pavement and must be free from loose material.
- 9.8. No towing vehicle braking system or other contrived means must contribute to braking effort and the towing vehicle engine must be declutched or neutral engaged, during the braking tests required by this rule.
- 9.9. The '*Brakes*' may be burnished before conducting any effectiveness tests according to the brake manufacturer's recommended procedures.
- 9.10. The '*Brake System*' must be adjusted in accordance with the brake manufacturer's recommendations before performance tests are conducted.
- 9.11. The performance requirements must be met with no deviation of the vehicle from its course greater than 300 millimetres.
- 9.12. No part of the '*Brake System*' must exceed 100°C immediately prior to the commencement of a brake test sequence.

10. SERVICE BRAKE EFFECTIVENESS TEST CONDITIONS

- 10.1. The initial speed at the point where trailer braking commences must be:
- 10.1.1. for trailers having an '*Aggregate Trailer Mass*' up to 45 tonnes and not being restricted by design speed limitations, 58 to 64 km/h.
- 10.1.2. for trailers having a '*Aggregate Trailer Mass*' greater than 45 tonnes, or special trailers having a design speed less than 58 km/h, not less than the '*Manufacturer's*' nominated design speed.
- 10.2. The trailer must be braked to a stop from initial speed starting with a '*Control Signal*' of 0.2 '*E*' and in increasing increments of not greater than 0.2 '*E*' for subsequent stops until an '*Established Retardation Coefficient*' of not less than 0.45 is achieved.

- 10.3. In the case of a compressed air '*Brake System*' the '*Control Signal*', applied to the '*Control Line*' at the front of the trailer, must reach 65 percent of the final value in less than 0.4 second.
- 10.4. '*Stopping Distance*' or '*Stopping Time*' may be used to calculate the '*ERC*' according to the equations in clause 10.5.
- 10.5. The '*Service Brake System*' '*ERC*' must be determined according to the following as required:

$$ERC = \frac{0.00394V^2}{S - 0.278T_R V} \times \frac{'Total\ Combination\ Mass'}{'Total\ Trailer\ Axle\ Load'}$$

$$ERC = \frac{0.0283V}{T - T_R} \times \frac{'Total\ Combination\ Mass'}{'Total\ Trailer\ Axle\ Load'}$$

where:

V is the initial speed in km/h

S is the '*Stopping Distance*' in metres

T is the '*Stopping Time*' in seconds

T_R is the response time measured from the time the '*Control*' leaves the '*Initial Brake Control Location*' until the energy level at the least favoured actuator reaches 65 percent of final value

'*Total Combination Mass*' in tonnes

'*Total Trailer Axle Load*' in tonnes with the trailer loaded as specified in clause 9.6

- 10.6. The computed '*Established Retardation Coefficients*' determined from clause 10.5 must comply with clause 6.5, where a test was not conducted at 1.0 '*E*' the '*ERC*' from a test conducted at 0.8 '*E*' or greater may be increased pro-rata to derive '*ERC*' at 1.0 '*E*'.
- 10.7. No trailer wheels must remain locked, except below 15 km/h, during completion of the braking tests required by part 10.
- 10.8. Allowance must be made for the effect of the increased rolling resistance resulting from the combination of vehicles being used to carry out the tests.

11. DOG TRAILER FRICTION UTILISATION

- 11.1. In the case of '*Dog Trailers*' at least one front '*Axle*' must skid before at least one rear '*Axle*' at an '*ERC*' greater than:

- (a) 0.3 in the case of two 'Axle' 'Dog Trailers';
- (b) 0.15 in the case of 'Dog Trailers' with three or more 'Axles'.

- 11.2. The test must be conducted generally in accordance with part 10 with the 'Control Signal' and surface type selected to demonstrate the requirement of clause 11.1 above.
- 11.3. The initial speed requirement of part 10 does not apply.

12. SERVICE BRAKE FADE EFFECTIVENESS TEST

- 12.1. The 'Service Brake System' must, on the next application after not less than 20 successive applications, each not more than 70 seconds after the preceding one and with the total of 20 applications completed within 20 minutes, of the trailer 'Brakes' from an initial speed of V_1 km/h to a final speed as calculated below or by clause 12.2, achieve a calculated 'Established Retardation Coefficient', when tested in accordance with part 10, at a nominated 'Control Signal' level, of not less than 60 percent of the value obtained at that 'Control Signal' level for the Service Brake Effectiveness Test required by part 10 nor less than 80 percent of the value specified by the lower boundary of Figure 1 at that 'Control Signal' level. The nominated 'Control Signal' level chosen must not be less than that necessary to produce a calculated 'Established Retardation Coefficient' of 0.45 under the Service Brake test conditions described in part 10 without prior fade conditioning stops.
- 12.2. The final speed to which the trailer has to be successively braked as part of the brake fade conditioning procedure must be determined from the equation

$$V_1^2 - V_2^2 = 2700 \times \frac{\text{'Gross Trailer Mass'}}{\text{'Total Combination Mass'}}$$

where:

V_1 is the initial speed in km/h;

V_2 is the final speed in km/h;

Masses and Loads in tonnes

- 12.3. The temperature (100°C) requirement of clause 9.12 does not apply to the test required by clause 12.1.

13. EMERGENCY BRAKE SYSTEM EFFECTIVENESS TEST

- 13.1. The 'Established Retardation Coefficient', as determined by clause 10.5 with must be determined by a test to the requirements of part 10 except where clause 13.2 applies, and except that:
- 13.1.1. The 'Control Signal' source must be left in the "off" position with no 'Control Signal' being provided to the trailer control line; and

- 13.1.2. The energy level in the '*Supply Line*' must be reduced to zero (in a 2-line compressed air system this will be the emergency line).
- 13.2. Where the actuation of the '*Emergency Brake System*' depends on one or more sources of '*Stored Energy*' that are common to the '*Service Brake System*', for the purposes of testing for compliance with the requirements of clause 13.1, the trailer energy storage devices must be charged to an energy level no greater than 0.05 '*E*' above the supply level determined for clause 5.5, or the energy storage device level if higher, at which the '*Emergency Brake System*' commences to activate the '*Brakes*'.
- 13.3. Wheel-locking at ERC above 0.18 is permitted.

14. PARKING BRAKE EFFECTIVENESS TEST

- 14.1. The '*Parking Brake System 38/...*' must be able to meet the requirements of clause 8.6 for a 5 minute period in each direction with the force required to actuate the parking brake not exceeding 685 N in the case of a foot operated brake and not exceeding 590 N in the case of a hand operated brake.
- 14.1.1. The necessary longitudinal force will be considered to have been applied if the sum of the force applied to the trailer towing point and the force due to the effect of gravity on the laden trailer mass, in the direction parallel to the test surface and trailer longitudinal axis, is greater than 0.18 times the '*Aggregate Trailer Mass*'.
- 14.1.2. Where the test involves a force depending on the slope of the test surface, the slope must not be less than 10 percent.
- 14.1.3. When the test involves the action of slope on the trailer or combination mass, and the towing vehicle remains connected, 1.5 percent of the towing vehicle mass must be subtracted from the other forces parallel to the test plane, to allow for rolling friction.
- 14.1.4. The test slope must be specified in terms of unit vertical per unit horizontal distance expressed as a percentage.
- 14.2. The '*Parking Brake System 38/...*' must meet the requirements of clause 13.1 when the '*Foundation Brakes*' geometry is such that a reversal of the required braking torque will not reduce the ability of the '*Parking Brake System 38/...*' to generate the required braking torque.

15. TIME RESPONSE MEASUREMENT

- 15.1. Except where hydraulic brakes are used, each '*Unique*' trailer '*Brake System*' must be shown to meet the requirements of clause 6.3 and 6.4 by testing in accordance with clause 15.3 or in accordance with part 20.

- 15.1.1. Where a vehicle is fitted with a '*Variable Proportioning Brake System*' the test must be conducted with the '*Variable Proportioning Brake System*' set at the mass specified in clause 6.5.1.
- 15.2. A variant of a '*Unique*' trailer '*Brake System*' will be considered to be identical in regard to time response, when the only variation from the '*Unique*' '*Brake System*' is one or more of the following:
- 15.2.1. Plumbing or energy transmission line lengths and number of fittings are reduced but other characteristics including diameter, material, type of connecting fittings and the characteristic transmission loss per unit length are not changed.
- 15.2.2. Entire subsections of the '*Brake System*' have been removed, as would be the case in converting a modular three '*Axle*' system to a modular two '*Axle*' system, such that the effect if any is to slightly increase the energy flow rate to and from the remaining brake sub-systems.
- 15.2.3. The energy required to actuate the substitute brake actuators to their maximum design level is less.
- 15.3. Where a trailer '*Brake System*' is required to be tested for compliance with clauses 6.3 and 6.4 in the case of compressed air '*Brake System*', the test rig described in Figure 3 must be calibrated in accordance with clause 15.4 and connected as described in Figure 4.
- 15.4. The test rig described in Figure 3 must be calibrated by adjustment of the orifice (O) such that; upon application of the brake control valve (V) with the storage reservoir (R1) charged to 1.0 '*E*' (650 kPa), the time interval is between 0.18 and 0.22 seconds from when the initial pressure drops measured between the storage reservoir and the control valve (V), or the initial pressure rises at the output of brake control valve (V), to when the pressure at the end of the calibrating vessel (R2) increases to 0.65 '*E*' (420 kPa).
- 15.5. Where a rear service coupling for towed trailers is provided, time responses must be measured with an 800-millilitre vessel attached to the rear service coupling as in Figure 4.
- 15.6. The test rig and the trailer energy storage devices must be charged to 1.0 '*E*' (650 kPa) prior to the test being conducted and no additional energy must be added to the storage vessel (R1) or the trailer '*Supply Line*' during the period of the test.
- 15.7. The brake actuation time must be taken from when the pressure level, measured between the storage reservoir and the control valve (V) initially drops, or measured at the output of brake control valve (V) initially rises to when the pressure in the least favoured brake actuator reaches 0.65 '*E*' (420 kPa).

- 15.8. With an initial service brake application level of 1.0 'E' (650 kPa) the brake release time must be taken from when the pressure level, measured between the control valve and the orifice, initially drops to the greater of when the pressure in the least favoured brake actuator reaches 0.05 'E' (35 kPa) or when the friction materials cease to contact each other.
- 15.9. The brake control valve must be of a configuration such that;
- 15.9.1. it permits energy to flow from the storage reservoir to the orifice (O) when in the "ON" position and from the orifice to waste when in the "OFF" position; and,
- 15.9.2. it must not allow additional energy to flow into the test rig 'Control Line' by way of its own 'Control Signal'; and
- 15.9.3. it must be designed so that the manner of its operation has no effect on the output response of the test rig; and
- 15.9.4. it may be arranged to provide a modulated test rig output signal for other brake development purposes which will be rendered inoperative for the purpose of measuring trailer 'Brake System' response in accordance with clause 15.3.

16. SERVICE BRAKE EFFECTIVENESS CALCULATION

- 16.1. In the case of an 'Axle Group' fitted with a 'Brake Reactive Suspension' the distribution of braking effort amongst the 'Axles' in an 'Axle Group' must be in the range of 'Skid Limit' values determined for the suspension in accordance with clause 21.4.
- 16.2. In the case of 'Dog Trailers' at least one front 'Axle' must have a higher friction utilisation than that of at least one rear 'Axle' at decelerations greater than:
- (a) 0.3 g in the case of 2 'Axle' 'Dog Trailers',
- (b) 0.15 g in the case of 'Dog Trailers' with 3 or more 'Axles'.
- 16.2.1. In the case of two-'Axle' 'Dog Trailers'-the friction utilisation factors may be calculated according to

$$\text{Friction Utilization Factor} = \frac{\text{Tangential Force at wheel}}{\text{Dynamic Load at Wheel}}$$

so:

$$F_2 = \frac{T_1}{P_1 + \frac{zhP}{L}}$$

and:

$$F_2 = \frac{T_2}{P_2 - \frac{zhP}{L}}$$

T_1 Tangential Force at front wheel (N)

T_2 Tangential Force at rear wheel (N)

F_1 Friction utilisation factor for front wheel

F_2 Friction utilisation factor for rear wheel.

P_1 front 'Axle' static load (N)

P_2 rear 'Axle' static load (N)

P total static 'Axle Load' (N)

h height of trailer and load centre of mass (m)

L 'Wheel Base' (m)

Z deceleration, as a proportion of acceleration due to gravity.

16.2.2. No friction utilisation factor (F) must exceed 0.7 at $z = 0.45$ (a friction utilisation factor of greater than 0.7 is taken as to mean that wheel lock would have occurred in the physical test otherwise required by part 10.

16.3. The 'Established Retardation Coefficient' of the trailer must be calculated using the formula in clause 16.3.2 at levels of input 'Control Signal' starting no higher than 0.2 'E' and increasing in increments of not more than 0.2 'E' until an 'Established Retardation Coefficient' of not less than 0.45 is achieved.

16.3.1. All calculated 'Established Retardation Coefficient' values must lie between the upper and lower boundaries of Figure 1 or Figure 2, as specified in clause 6.5.

16.3.2. The 'Established Retardation Coefficient' must be calculated by

$$ERC = \frac{\text{total brake force at e}}{\text{'Total Trailer Axle Load'}} = \frac{e \left[\frac{C_1 T_1}{R_1} + \frac{C_2 T_2}{R_2} + \text{etc.} \right]}{(P_1 + P_2 + \text{etc.})}$$

where:

e is the value of 'E'

C is the ratio of output Signal Level to '*Control Signal*' strength for the '*Control System*' for the '*Axle*' concerned

T is the '*Brakes*' output torque per unit input signal to the '*Brakes*' actuator from output of the '*Control System*' for the '*Axle*' concerned.

R is the rolling radius of the tyre on the wheel

P is the static load on the '*Axle*' concerned

1, 2, etc are subscripts referring to the concerned '*Axle*'.

'*Total Trailer Axle Load*' in tonnes with the trailer loaded as specified in clause 9.6

17. SERVICE BRAKE FADE CALCULATION

17.1. The '*Service Brake System*' will be considered to have sufficient brake fade resistance to meet the requirements of this rule if the '*Gross Axle Load Rating*' of each '*Foundation Brake*' rated according to the fade test in clause 21.3.6 is greater than the '*Gross Trailer Mass*' multiplied by the percentage of total brake torque provided by that '*Foundation Brake*' for at least one '*Control Signal*' level necessary to produce a calculated '*Established Retardation Coefficient*' of not less than 0.45 under the Service Brake test Conditions described in part 10 without prior fade conditioning stops.

18. EMERGENCY BRAKE SYSTEM CALCULATION.

18.1. The '*Established Retardation Coefficient*' for the '*Emergency Brake System*' must be determined by computing the total braking force (kN) at the wheels to which emergency brakes are fitted and dividing by $[9.81 \times \text{'Gross Trailer Mass'} \text{ (tonnes)}]$.

18.2. The braking force at each '*Axle*' must be calculated according to

$$F = \frac{A \times T}{R}$$

where:

F is the tangential force at the braked wheels on the '*Axle*' concerned

A is the input to the emergency brakes actuator in units of '*E*'

T is the '*Brakes*' output torque per 1.0 '*E*' for the '*Emergency Brake System*'

R is the rolling radius of the tyre fitted to the wheel.

- 18.2.1. Where the actuating force is dependent on the stroke, as in the case of spring brakes, the value of A used in the equation above must be that corresponding to the '*Brakes*' actuator stroke achieved by the '*Emergency Brake System*'. This can be determined by plotting on a graph of '*Control Signal*' versus stroke as detailed in clauses 18.2.2 and 18.2.3:
- 18.2.2. The input to the emergency brakes actuator in units of '*E*' from the data provided for the '*Control System*' at various strokes; and
- 18.2.3. The '*Foundation Brake*' stroke achieved at various '*Control System*' inputs.

19. PARKING BRAKE CALCULATION

- 19.1. The gradient, expressed as a percentage, on which the '*Parking Brake System 38/...*' can hold the trailer must be determined by computing the total braking force at the wheels (N) to which the '*Parking Brake System 38/...*' is fitted and dividing by [98.1 x '*Aggregate Trailer Mass*' (tonnes)]
- 19.2. The braking force at each '*Axle*' must be calculated according to

$$F = \frac{A \times T}{R}$$

where:

F is the tangential force at the braked wheels on the '*Axle*' concerned

A is the input to the park brake actuator in units of '*E*'

T is the '*Brakes*' output torque per 1.0 '*E*' for the '*Park Brake System*'

R is the rolling radius of the tyre fitted to the wheel.

- 19.3. The provisions of clause 18.2.1, 18.2.2 & 18.2.3. must apply.
- 19.4. When '*Emergency Brake System*' performance data is used to demonstrate compliance of the '*Parking Brake System 38/...*', the geometry of the '*Brakes*' must be such that brake effectiveness will be not less in the reverse direction.

20. TIME RESPONSE

- 20.1. The time response of a '*Service Brake System*' may be taken as complying with the requirements of this rule if the '*Service Brake System*' is installed in a manner identical to that prescribed in the documentation describing the '*Approved*' '*Control System*' used, except as allowed in clause 20.2.

- 20.2. Actuator volumes at full '*Foundation Brake*' stroke and line lengths may be reduced and actuator volumes at the point when the '*Foundation Brake*' friction materials cease to contact each other may be increased (for release response test) from those specified in the '*Approved*' '*Control System*' documentation, but other devices, fittings and dimensions may not be changed.

21. SPECIFICATION OF BRAKE SYSTEM COMPONENTS

- 21.1. Sub-assemblies of '*Brake System*' components may be '*Approved*' by the '*Administrator*' as part of the '*Brake System*' approval process where information has been supplied in accordance with the requirements of the appropriate sub-paragraphs of clause 21.
- 21.2. '*Control System*'
- 21.2.1. The '*Control System*' must be characterised by determining the '*Control System*' ratio at not less than five points in the range of '*Control Signal*' inputs at 0.2 '*E*' to 1.0 '*E*'. These points must be equally spaced except where the relationship within that range is non-linear, in which case the points must include each critical point
- 21.2.1.1. The '*Control System*' ratio for each axle is Output Signal level as a percentage of '*Control Signal*' level.
- 21.2.1.2. The input must be taken at the trailer coupling.
- 21.2.1.3. The output must be taken at the outlet end of the line to the service brake actuator.
- 21.2.2. The input signal strength must be the final value of the applied signal and must be applied to the '*Control System*' such that it rises from zero to 65 percent of the final value in not more than 0.22 second. In the case of air '*Brake System*'s the input '*Control Signal*' strength (kPa) will be measured at the trailer '*Control Line*' coupling.
- 21.2.3. The output signal strength must be the final value of the signal generated for control of the '*Brakes*' actuator and which must be reached in not more than two seconds. The output signal strength will be measured in the actuator attached to each output having a fundamentally different relation to the input. In the case of air '*Brake Systems*' a '*Control Signal*' path having additional pressure limiters, relay valves or other active devices will be considered as being fundamentally different.
- 21.2.4. Time response must be measured where necessary in accordance with part 15.
- 21.2.5. Where the '*Control System*' is not installed on an actual trailer, it must be installed in an essentially identical manner, in the laboratory, with all bends, fittings and worst case line lengths and representative actuator volumes installed.

- 21.2.6. For the application test, clause 15.7, the actuator displacement must be the largest volume for which the '*Control System*' is designed and it may be represented by an equivalent fixed volume.
- 21.2.7. The release test, clause 15.8, must commence at an actuator displacement corresponding to the largest volume for which the '*Control System*' is designed. Alternatively the actuators may be replaced by an equivalent fixed volume.
- 21.2.8. All relevant test conditions pertaining to part 9 must be complied with.
- 21.2.9. The relationship between brake actuator volume and stroke must be measured and plotted from zero to full actuator stroke.
- 21.2.9.1. Where more than one actuator type is used, a plot for each actuator must be supplied. If several plots are shown on one graph, each plot must be identified and clearly related to the actuator details.
- 21.2.9.2. If the relationship between stroke and volume is not linear, all critical points must be measured and plotted.
- 21.2.9.3. The value of the maximum brake actuator design stroke and volume must be stated.
- 21.3. '*Foundation Brakes*'
- 21.3.1. The effectiveness of the '*Foundation Brakes*' must be characterised by comparing the energy level of the signal provided to the '*Brakes*' actuator against the output brake torque of the '*Brakes*' device at not less than five points in the range 0.2 '*E*' to 1.0 '*E*'. These points must be equally spaced. Where a test was not conducted at 1.0 '*E*', the torque from a test conducted at 0.8 '*E*' or greater may be increased pro-rata to derive output torque at 1.0 '*E*'.
- 21.3.2. Parameters relevant to the specification of the '*Brakes*' actuator including its stroke at each energy level of the signal provided to the '*Brakes*' actuator must be recorded. In the case of '*S-Cam*' air systems this will include the actuator size, slack adjuster length and any other special feature.
- 21.3.3. Measurements must be taken in accordance with the relevant conditions for the road test described in parts 9 and 10.
- 21.3.4. The '*Brakes*' must be burnished before conducting any effectiveness tests according to the brake manufacturer's recommended procedures.
- 21.3.5. Specification of effectiveness for '*Foundation Brakes*' must be on the basis of '*Axle*' performance with two brake assemblies rather than wheel performance.
- 21.3.6. The '*Foundation Brake*' must, on the next application after not less than 20 successive applications, each not more than 70 seconds after the

preceding one and with the total of 20 applications completed within 20 minutes, of the trailer *'Brakes'* from an initial speed of V_1 km/h to a final speed as calculated by clause 21.3.6.1, achieve a calculated brake torque, when tested in accordance with part 10, at a nominated energy level of the signal provided to the *'Brakes'* actuator, of not less than 60 percent of the brake torque achieved at that Actuator Supply Energy level when tested in accordance with clause 21.3.1. The chosen, nominated energy level of the signal provided to the *'Brakes'* actuator, must not be less than that necessary to produce a calculated *'Established Retardation Coefficient'* of 0.45 under the Service Brake test Conditions described in part 10 when laden to the *'GALR'* without prior fade conditioning stops.

- 21.3.6.1. The final speed to which the trailer has to be successively braked as part of the brake fade conditioning procedure must be determined from the equation

$$V_1^2 - V_2^2 = 2700 \times \frac{\text{'Gross Axle Load Rating'}}{\text{'Total Combination Mass'}}$$

where:

V_1 is the initial speed in km/h

V_2 is the final speed in km/h

Masses and Loads in tonnes

- 21.3.6.2. The temperature (100 °C) requirement of clause 9.3 does not apply to the test required by clause 12.1.

- 21.4. Suspension Behaviour, *'Brake Reactive Suspensions'* only.

- 21.4.1. *'Suspension Systems'* for other than hinged drawbar *'Pig Trailers'*.

- 21.4.1.1. The suspension must be installed according to the *'Manufacturer's'* instructions to a representative trailer, be fitted with *'Axles'*, wheels and tyres of a size appropriate to the mass rating of the suspension, and be fitted with identical "Pre-calibrated" *'Brakes'* at each *'Axle'*.

- 21.4.1.1.1. "Pre-calibrated" in this case means that the relationship between the input actuation energy level and the output torque for the *'Brakes'* on each *'Axle'* has been measured.

- 21.4.1.2. To determine the *'Service Brake System'* *'Skid Limit'* a Service Brake Effectiveness Test must be conducted applying the brakes on all *'Axles'* of the trailer and using the General Test Conditions of part 9 and generally in accordance with the particular conditions of part 10 with **not** less than 50% of the *'Suspension Systems'* rated *'Axle Group'* load used in place of *'Gross Trailer Mass'*. Clause 10.2 need not be complied with.

- 21.4.1.3. The test result must be reported as the value of the computed retardation force for each 'Axle' divided by the greatest of the 'Axle' retardation forces at which an 'Established Retardation Coefficient' of 0.45 can be achieved without wheel lock.
- 21.4.1.3.1. In the case of 'S-Cam' air 'Brake Systems' the overall effect of changing actuator and slack adjuster sizes can be simulated by individually adjusting the air pressure to each 'Axle'.
- 21.4.2. 'Suspension Systems' for hinged drawbar 'Pig Trailers'.
- 21.4.2.1. The suspension must be installed according to the manufacturer's instructions to a representative trailer, be fitted with 'Axles', wheels and tyres of a size appropriate to the mass rating of the suspension, and be fitted with identical "Pre-calibrated" 'Brakes' at each 'Axle'.
- 21.4.2.1.1. "Pre-calibrated" in this case means that the relationship between the input actuation energy level and the output torque for the 'Brakes' on each 'Axle' has been measured.
- 21.4.2.2. The trailer must be laden such that the 'Axle Group' load equals the suspension system's rated 'Axle Group' load and that the centre of gravity of the trailer is at the same height as for a typical trailer laden to the rated 'Axle Group'.
- 21.4.2.3. To determine the 'Service Brake System' 'Skid Limit' a Service Brake Effectiveness Test Conditions test must be conducted applying the brakes on all 'Axles' on both the trailer and the towing vehicle such that the computed retardation of the trailer is within 0.05 m/sec^2 of that of the towing vehicle.
- 21.4.2.4. The computed retardation must be derived from tests of each vehicle braked alone comparing the 'Control Signal' at the truck to trailer coupling with the retardation achieved.
- 21.4.2.5. The test must be conducted using the General Test Conditions of part 9 and the generally in accordance with the particular conditions of part 10. Clause 10.2 need not be complied with.
- 21.4.2.6. The test result must be reported as the value of the indicated retardation force for each 'Axle' divided by the greatest of the 'Axle' retardation forces at which an 'Established Retardation Coefficient' of 0.45, calculated with 'Total Combination Mass' held equal to 'Gross Trailer Mass', can be achieved without wheel lock.
- 21.4.2.6.1. In the case of 'S-Cam' air 'Brake Systems' the overall effect of changing actuator and slack adjuster sizes can be simulated by individually adjusting the air pressure to each 'Axle'.

22. ALTERNATIVE STANDARDS

- 22.1. The technical requirements adopted by the United Nations – Economic Commission for Europe (UNECE) Regulation No. 13 – UNIFORM PROVISIONS CONCERNING THE APPROVAL OF VEHICLES OF CATEGORIES M, N AND O WITH REGARD TO BRAKING, incorporating any of the series of amendments from 05 to 10 shall be deemed to be equivalent to the technical requirements of this standard, provided that the requirements of clauses 6.7 and 8.2 are met and provided that, in the case of trailers, other than ‘*Pig Trailers*’ that are not ‘*Converter Dollies*’, designed for use in ‘*Road Trains*’ having a ‘*Gross Combination Mass*’ not exceeding 125 tonnes, the requirement of clause 6.4 is also met.
- 22.2. Computer simulation of the requirements of part 10 is allowed where the simulation is sufficiently sophisticated and has been ‘*Approved*’ on the basis of an adequate back to back comparison with physical test results.
- 22.3. For trailers not fitted with a ‘*Variable Proportioning Brake System*’, certification evidence for ADR 38/02 that has been ‘*Approved*’ at or before the date set out in clause 2 will be deemed to comply with this rule.

TABLE 1
GROUP 'AXLE LOAD' LIMITS

Number of 'Axles' in 'Axle Group'	Tyre Type "a" and Configuration	Group 'Axle Load' Limit (tonnes)
1	S D W ₁ W ₂ D	6.0 9.0 6.7 7.0 10.0 (RFS)
2	S S S D W ₁ W ₁ D D W ₂ W ₂ D D	11.0 13.0 13.3 16.5 14 17.0 (RFS)
3	S S S D D D W ₁ W ₁ W ₁ or W ₂ W ₂ W ₂ D D D	15 20.0 20.0 22.5 (RFS)

Tyre Type "a":

- S Single tyre per wheel
D Dual tyres per wheel
W₁ 'Wide Single Tyre' (375 to 450 mm width)
W₂ 'Wide Single Tyre' (over 450 mm width)
RFS 'Road Friendly Suspension'
-

FIGURE 1
'GTM' (LADEN)
SERVICE BRAKE EFFECTIVENESS

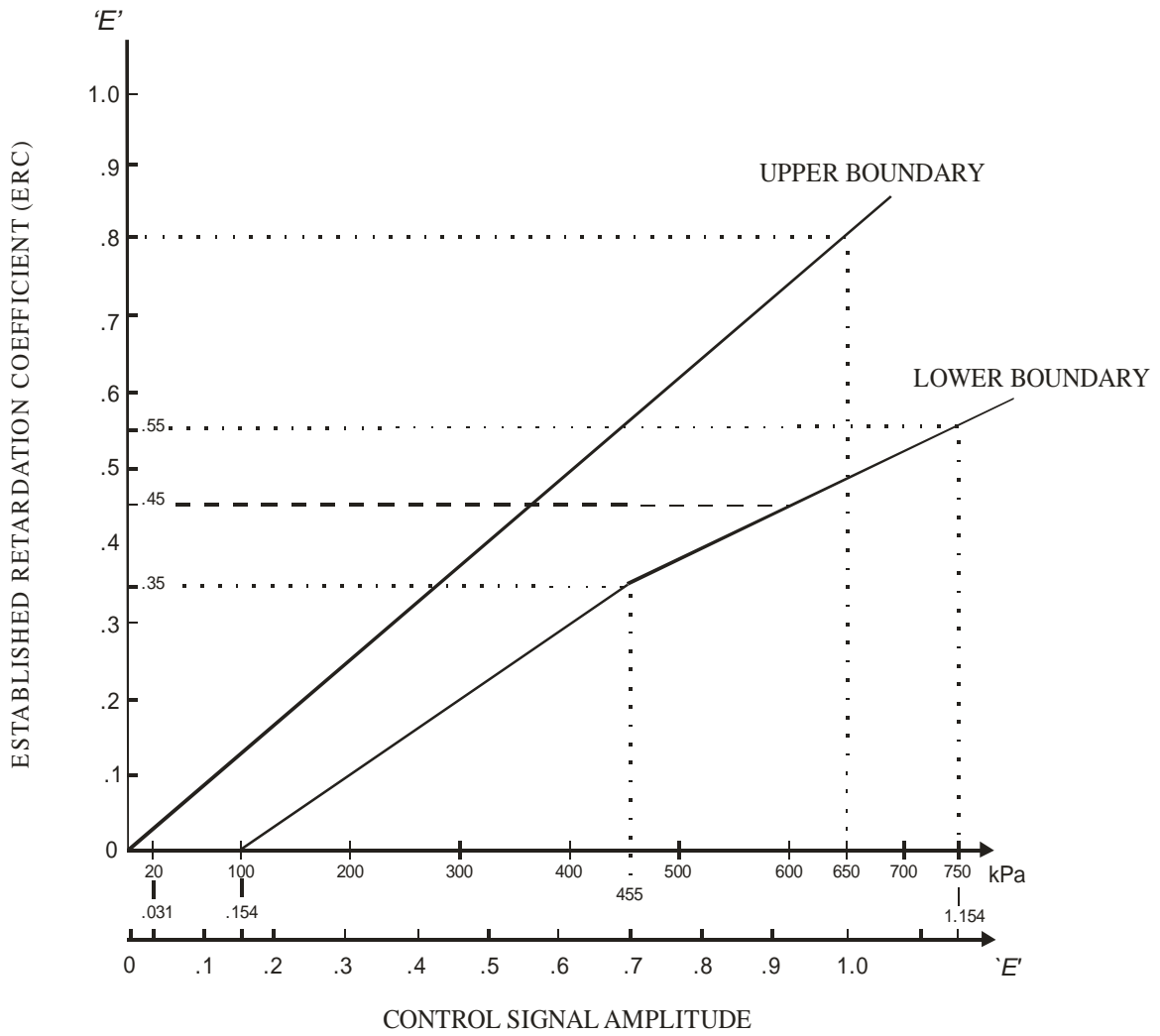
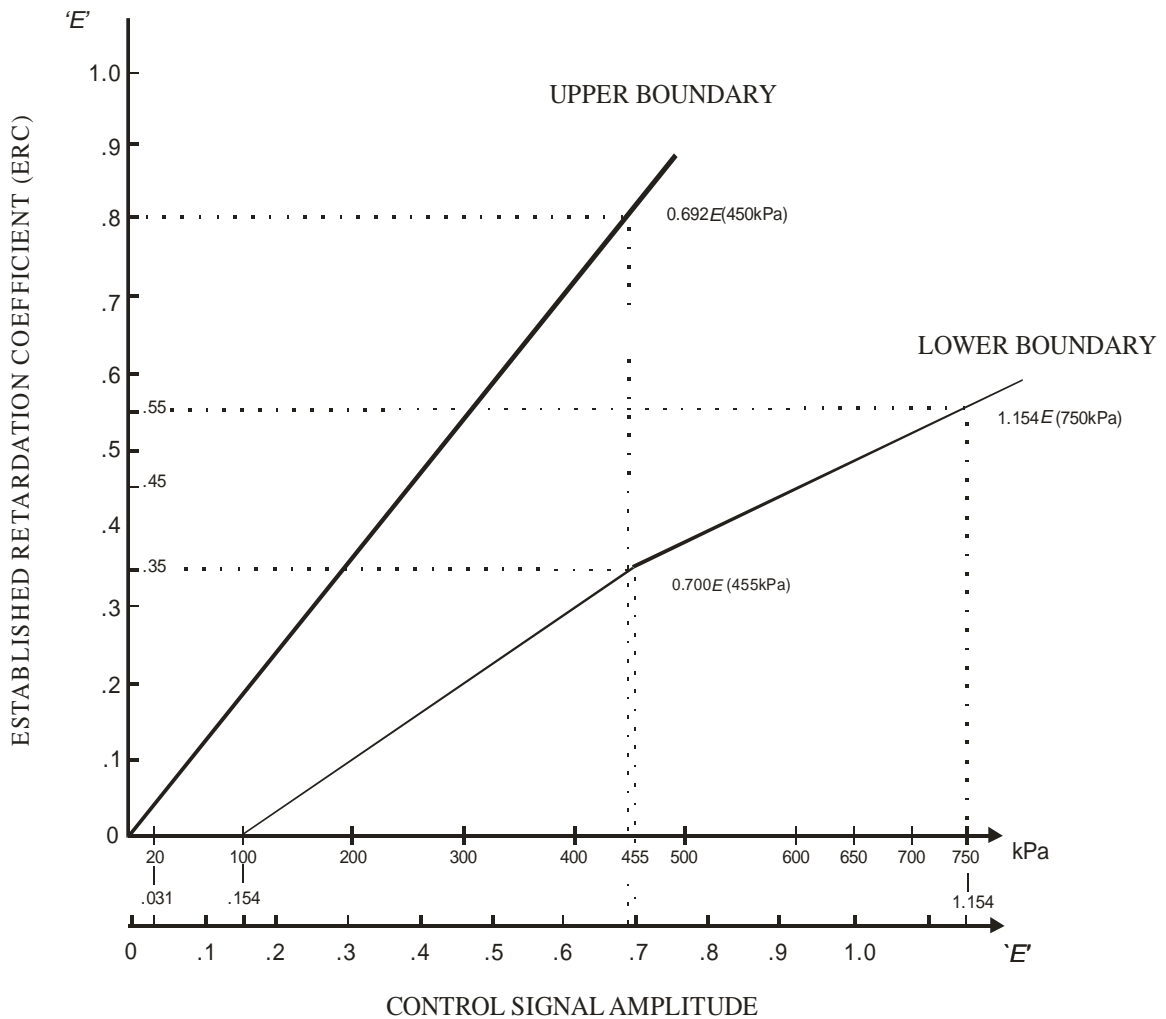

FIGURE 2
 'UTM' (UNLADEN)
 SERVICE BRAKE EFFECTIVENESS



Note: The relationship required by the diagram shall apply progressively for the intermediate states of loading between the laden (Figure 1) and the unladen (Figure 2) states and shall be achieved by automatic means.

USE OF TRAILER COMPRESSED AIR BRAKE TEST RIG

FIGURE 3 - CALIBRATION OF TEST RIG

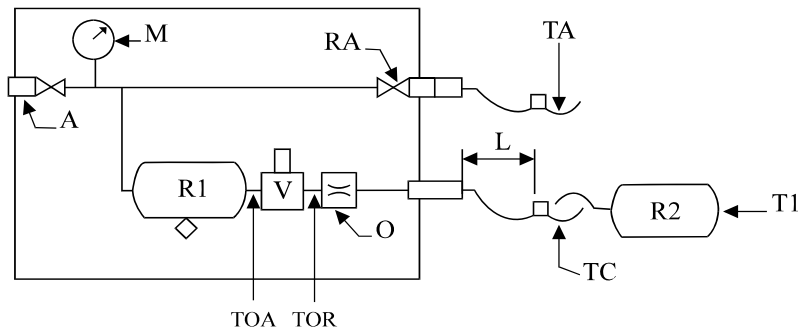
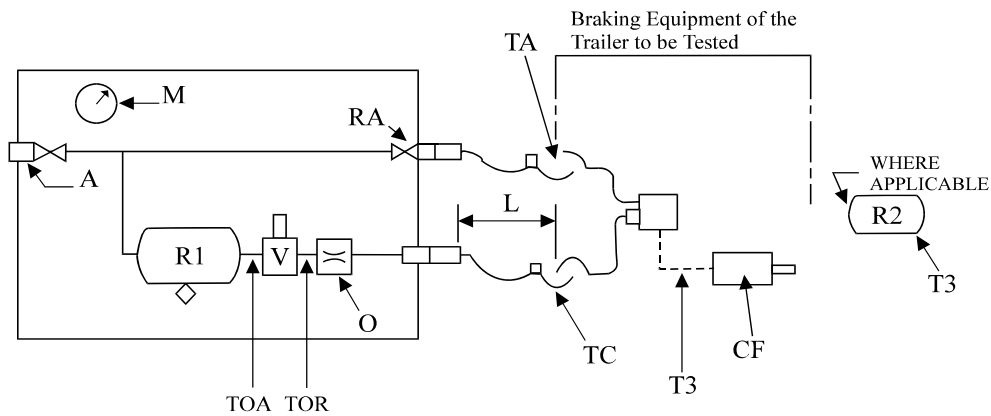

FIGURE 4 - TESTING THE TRAILER



NOMENCLATURE FOR FIGURES 3 AND 4

- A = supply connection with single check valve and regulator set at 650 kPa
- CF = trailer brake actuator
- L = coupling hose, 13 mm nominal bore and 2.5 metres long
- M = pressure gauge
- O = orifice (see clause 15.4)
- R1 = reservoir of not less than 30,000 ml
- R2 = calibrating vessel of 800 ± 5 ml
- RA = shut off valve
- TA = coupling head - supply (emergency)
- TC = coupling head - control (service)
- TOA = transducer point for timing inlet to brake actuation time
- TOR = transducer point for timing inlet to brake release time

- T1 = transducer point for calibration at end of R2 reservoir
- T2 = transducer point for testing rear tow coupling of trailer
- T3 = transducer point for testing trailer
- V = brake control valve

APPENDIX 1

Special Provisions for TC Category Trailers over 4.5 Tonnes ATM and TD Category Trailers Incorporating an 'Antilock System'

1. PERFORMANCE REQUIREMENTS

- 1.1 The 'Brake System' of trailers must comply with the requirements of this ADR including clause 6.5 with the 'Antilock Systems' operational and in the event of a failure of the 'Antilock System' .
- 1.2 At speeds exceeding 15 km/h the wheels on the 'Axle(s)' specified in clause 2.1 of this APPENDIX must remain unlocked when a 'Control Signal' of 1.0 'E' (650 kPa) is suddenly applied from an initial speed of 40 km/h +5 to -1 km/h and from an initial speed of at least 80 km/h on a road surface having approximately uniform surface friction on both sides of the vehicle.
- 1.2.1 This test is to be performed with the trailer laden to both 'Lightly Laden Test Mass' and 'Maximum Loaded Test Mass' and using the general test conditions from clause 9 and the particular test conditions from clause 10, amended as regards 'Control Signal' amplitude and application rates.
- 1.2.2 Brief periods of locking of the wheels are allowed, but stability must not be affected.
- 1.1.3 The operation of an 'Antilock System' must not be adversely affected by magnetic or electric fields.

2. INSTALLATION REQUIREMENTS

- 2.1 An 'Antilock System' complying with clause 1 of this APPENDIX must be fitted to:
- 2.1.1 each 'Single Axle';
- 2.1.2 at least one 'Axle' in any 'Tandem Axle Group';
- 2.1.3 at least two 'Axles' in any 'Triaxle Group'.

3. ANTILOCK SYSTEM - ELECTRICAL SYSTEM.

- 3.1 'Antilock Systems' must be powered by a 12 or 24 volt electrical supply system, through a connection to the towing vehicle, using a connector conforming to DIN Standard 72570 configured for 12 volt operation or ISO/DIN7638:1996 configured for 12 or 24 volt operation. If configured for 24 volt operation, the voltage must be marked on the plug.
- 3.2 The connector must be wired to have the following functions:
- 3.2.1 For trailers with a 12 volt system:

Pin 1 +ve high current trailer solenoid valve supply, 20 amps minimum rated capacity 30 amps peak capacity

Pin 2 +ve low current trailer electronic unit supply, 4 amps minimum rated capacity

Pin 3 -ve low current trailer electronic unit supply, 6 amps minimum rated capacity

Pin 4 -ve high current trailer solenoid valve supply, 20 amps minimum rated capacity 30 amps peak capacity

Pin 5 trailer '*Antilock System*' failure, switched to -ve (eg pin 3 or pin 4) upon fault detection, 2 amps minimum rated capacity

3.2.2 For trailers with a 24 volt system:

Pin 1 +ve high current trailer solenoid valve supply, 10 amps minimum rated capacity 15 amps peak capacity.

Pin 2 +ve low current trailer electronic unit supply, 2 amps minimum rated capacity

Pin 3 -ve low current trailer electronic unit supply, 3 amps minimum rated capacity

Pin 4 -ve high current trailer solenoid valve supply, 10 amps minimum rated capacity 15 amps peak capacity

Pin 5 trailer '*Antilock System*' failure, switched to -ve (eg pin 3 or pin 4) upon fault detection, 1 amp minimum rated capacity

3.3 Any break in the supply of electricity to an '*Antilock System*' and any electrical failure of an '*Antilock System*' other than a failure of one or all of the electrical conductors between pins 3, 4 and 5 on the electrical connector and the antilock control module must be signalled to the towing vehicle by connecting Pin 5 on the electrical connector to -ve (ie pin 3 or pin 4).

3.4 Each '*Antilock System*' must connect pin 5 to -ve (eg pin 3 or pin 4) when initially energised and disconnect pin 5 from -ve after not less than 2 seconds or at the latest when the trailer reaches a speed of 15 km/h and no defect is present.

APPENDIX 2

**Example of Markings for Trailers
Fitted with a ‘Variable Proportioning Brake System’**

1. MARKING REQUIREMENTS

1.1 An example of markings for a mechanically controlled device in a trailer fitted with a compressed air ‘*Brake System*’ that meets clause 6.8.1 is shown below.

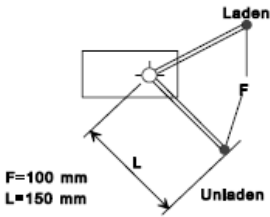
Control data	Vehicle loading	Axle No. 2 load at the ground [kg]	Inlet pressure [kPa]	Nominal outlet pressure [kPa]
	Laden	7000	600	600
	Unladen	2000	600	240

1.2 An example of markings for an air pressure controlled device in a trailer fitted with a compressed air ‘*Brake System*’ that meets clause 6.8.2 is shown below.

Control data	Vehicle loading	Axle No. 2 load at the ground [kg]	Suspension Pressure [kPa]	Nominal outlet pressure [kPa]
Inlet pressure [kPa] 600	Laden	7000	300	600
	Unladen	2000	100	240