



Vehicle Standard (Australian Design Rule 34/02 – Child Restraint Anchorages and Child Restraint Anchor Fittings) 2012

I, CATHERINE KING, Parliamentary Secretary for Infrastructure and Transport, determine this vehicle standard under subsection 7 of the *Motor Vehicle Standards Act 1989*.

Dated 20/ 3 / 2012

[Signed]

Catherine King

Parliamentary Secretary for Infrastructure and Transport.

CONTENTS

A.1. NAME OF STANDARD	3
A.2. COMMENCEMENT	3
B. SCOPE.....	3
C. APPLICABILITY AND IMPLEMENTATION	3
D APPLICABILITY TABLE	4
34.1. DEFINITIONS	5
34.2. GENERAL REQUIREMENTS.....	5
34.3. NOMINATED SEATING POSITIONS FOR UPPER ANCHORAGES	6
34.4. INFORMATION REQUIREMENTS	7
34.5. UPPER ANCHORAGE LOCATION REQUIREMENTS	7
34.6. ACCESSIBILITY TO ENGAGE AN ATTACHING CLIP	8
34.7. STRENGTH OF UPPER ANCHORAGES	8
34.8. REQUIREMENTS FOR ISOFIX ANCHORAGES	10
34.9. ALTERNATIVE STANDARDS	11
APPENDIX 1.....	24
APPENDIX 2.....	25

A.1. NAME OF STANDARD

- A.1.1. This Standard is the Vehicle Standard (Australian Design Rule 34/02 – Child Restraint Anchorages and Child Restraint Anchor Fittings) 2012.
- A.1.2. This Standard may also be cited as Australian Design Rule 34/02 — Child Restraint Anchorages and Child Restraint Anchor Fittings.

A.2. COMMENCEMENT

- A.2.1. This Standard commences on the day after it is registered.

B. SCOPE

- B.1. The function of this Australian Design Rule is to specify requirements for ‘*Upper Anchorages*’ (top tether anchorages) and ‘*Upper Anchor Fittings*’ (top tether anchor fittings) which provide for the connection of standard ‘*Upper Anchorage Strap*’ ‘*Attaching Clips*’ so that ‘*Child Restraints*’ may be adequately secured to the vehicle. It specifies a standard package of fitting hardware and accessibility requirements to facilitate correct installation and interchangeability of ‘*Child Restraints*’. It also specifies requirements for any lower anchorages, other than a vehicle ‘*Seatbelt Assembly*’, to which the lower portion of a ‘*Child Restraint*’ may be attached on a vehicle seat (such as ISOFIX low anchorages).

C. APPLICABILITY AND IMPLEMENTATION

This standard applies to the design and construction of vehicles as set out in clauses C.1, C.2 and the table below.

- C.1. 1 November 2012 on all new model vehicles.
- C.2. 1 November 2013 on all vehicles.
- C.3. For the purposes of clause C.1 a "new model" is a vehicle model first produced with a ‘*Date of manufacture*’ on or after the agreed date in clause C.1.
- C4. For MD3, MD4, and ME vehicles the circumstances under which ‘*Upper Anchorages*’ are mandatory are set out in ADR 68/.. .
- C5. ADR 34/01 is an acceptable prior rule for vehicles that do not have any means, other than a vehicle ‘*Seatbelt Assembly*’, of affixing the lower portion of a ‘*Child Restraint*’ to the vehicle (such as ISOFIX low anchorages) – see clause 34.8.1.

D APPLICABILITY TABLE

Vehicle Category	ADR Category Code ¹	UNECE Category Code*	Manufactured on or After	Acceptable Prior Rules
Moped 2 wheels	LA	L1	Not applicable	
Moped 3 wheels	LB	L2	Not applicable	
Motor cycle	LC	L3	Not applicable	
Motor cycle and sidecar	LD	L4	Not applicable	
Motor tricycle	LE	L5	Not applicable	
	LEM		Not applicable	
	LEP		1 November 2012**	34/01 [#]
	LEG		Not applicable	
Passenger car	MA	M1	1 November 2012**	34/01 [#]
Forward-control passenger vehicle	MB	M1	1 November 2012**	34/01 [#]
Off-road passenger vehicle	MC	M1	1 November 2012**	34/01 [#]
Light omnibus	MD	M2		
up to 3.5 tonnes 'GVM' and up to 12 seats	MD1		1 November 2012**	34/01 [#]
up to 3.5 tonnes 'GVM' and more than 12 seats	MD2		Not applicable	
over 3.5 tonnes and up to 4.5 tonnes 'GVM'	MD3		1 November 2012***	34/01 [#]
over 4.5 tonnes and up to 5 tonnes 'GVM'	MD4		1 November 2012***	34/01 [#]
Heavy omnibus	ME	M3	1 November 2012***	34/01 [#]
Light goods vehicle	NA	N1	Not applicable	
Medium goods vehicle	NB	N2		
over 3.5 tonnes up to 4.5 tonnes 'GVM'	NB1		Not applicable	
over 4.5 tonnes up to 12 tonnes 'GVM'	NB2		Not applicable	
Heavy goods vehicle	NC	N3	Not applicable	
Moped 2 wheels	LA	L1	Not applicable	
Moped 3 wheels	LB	L2	Not applicable	
Motor cycle	LC	L3	Not applicable	
Motor cycle and sidecar	LD	L4	Not applicable	

** See clauses C.1 to C.3

*** See clauses C.1 to C.4

[#] See clause C.5

¹ UNECE Vehicle Categories are provided for information and as reference only. The category code may also be in the format L₁, L_A etc.

34.1. DEFINITIONS

- 34.1.1. For vehicle categories, definitions and meanings used in this standard, refer to:
 - 34.1.1.1. Vehicle Standard (Australian Design Rule Definitions and Vehicle Categories) 2005; and
 - 34.1.1.2. Definitions in Section 2 of Appendix A of ADRs 4/... and 5/...; or
 - 34.1.1.3. Definitions in Section 2 of the standards specified in clauses 34.9.2 and 35.9.3 of this standard.

34.2. GENERAL REQUIREMENTS

- 34.2.1. Every vehicle shall provide the facility to attach an *'Upper Anchorage Strap'* *'Attaching Clip'* to an *'Upper Anchor Fitting'* for each seating position nominated in clause 34.3 by either:
 - 34.2.1.1. using the *'Upper Anchor Fitting Package'*, in which case:
 - 34.2.1.1.1. one *'Upper Anchor Fitting Package'* shall be installed in at least one seating position. This shall be in the centre rear seating position, if applicable; and
 - 34.2.1.1.2. for other positions, one 5/16 inch UNC-2A hexagon headed bolt and appropriate *'Spacer'* shall be supplied for each different variation from the standard *'Attachment Bolt'* length and shall be placed in the vehicle's glovebox; or
 - 34.2.1.2. using an *'Upper Anchor Fitting'* and appropriate attaching hardware other than in the *'Upper Anchor Fitting Package'*, in which case:
 - 34.2.1.2.1. an *'Upper Anchor Fitting'* shall be installed for at least one seating position. This shall be in the centre rear seating position, if applicable; and
 - 34.2.1.2.2. for other positions, one 5/16 inch UNC-2A hexagon headed bolt and appropriate *'Spacer'* shall be supplied for each different variation from the standard *'Attachment Bolt'* length and shall be placed in the vehicle's glovebox; or
 - 34.2.1.3. an *'Upper Anchor Fitting'* shall be installed for each nominated seating position, in which case:
 - 34.2.1.3.1. the *'Upper Anchor Fitting'* need only comply with Figure 2 in relation to the location and clearance of the *'Upper Anchor Fitting'* *'Interface Profile'*.
 - 34.2.1.4. Notwithstanding clauses 34.2.1.1.1 and 34.2.1.2.1 if the vehicle is fitted with a lap sash *'Seatbelt Assembly'* in the centre rear seating position the *'Upper Anchor Fitting'* may be installed in another seating position.
 - 34.2.1.4.1. For other positions, one 5/16 inch UNC-2A hexagon headed bolt and appropriate *'Spacer'* shall be supplied for each different variation from the standard *'Attachment Bolt'* length and shall be placed in the vehicle's glovebox.

- 34.2.2. Each ‘*Upper Anchorage*’ provided in accordance with clauses 34.2.1.1 or 34.2.1.2 shall:
- 34.2.2.1. incorporate a 5/16 inch - 18 UNC - 2B internal thread which will provide sufficient engagement of the ‘*Attachment Bolt*’ to meet the strength requirements of clause 34.7 when the ‘*Attachment Bolt*’ is retaining a ‘*Upper Anchor Fitting*’, ‘*Spacer(s)*’, attaching hardware and any trim or other material present;
- 34.2.2.2. be so designed and located that no items need to be removed to gain access to it for the installation of the ‘*Upper Anchor Fitting*’, except closure plugs, or other items, removable with the use of simple hand tools; and
- 34.2.2.3. provide clearance to enable the installation of the ‘*Upper Anchor Fitting*’, ‘*Spacer(s)*’ and attaching hardware.
- 34.2.3. For guidance to vehicle manufacturers the clearance parameters shown in Figure 7 are sufficient to demonstrate compliance with Clause 34.2.2.3.

34.3. NOMINATED SEATING POSITIONS FOR UPPER ANCHORAGES

- 34.3.1. For LEP and MA vehicles:
- 34.3.1.1. Each seating position in the ‘*Second Row Seats*’ equipped with an adult ‘*Seatbelt Assembly*’, except the following ;
- 34.3.1.1.1. the middle seating position where the ‘*Seat*’ back is divided into two or more sections which may be folded independently of each other, and the division between two sections lies substantially along the ‘*Seating Reference Plane*’ of the middle seating position.
- 34.3.1.1.2. a seating position with a ‘*Folding Seat*’ where a ‘*Child Restraint*’ would bar access to the rear ‘*Seats*’, provided that this does not reduce the number of ‘*Upper Anchorages*’ that would otherwise be fitted to the vehicle.
- 34.3.1.2. ‘*Upper Anchorages*’ or ‘*Upper Anchor Fitting(s)*’ may be installed in front seating positions other than the driver’s ‘*Seat*’.
- 34.3.2. For MB, MC and MD1 vehicles:
- 34.3.2.1. For vehicles with less than three seating positions in ‘*Vehicle Rear Seat(s)*’ each seating position in ‘*Vehicle Rear Seat(s)*’ equipped with an adult ‘*Seatbelt Assembly*’.
- 34.3.2.2. For vehicles with three or more seating positions in ‘*Vehicle Rear Seat(s)*’ any three seating positions in ‘*Vehicle Rear Seat(s)*’ equipped with an adult ‘*Seatbelt Assembly*’ except for ‘*Folding Seats*’ where a ‘*Child Restraint*’ would bar access to the rear ‘*Seats*’ and except the middle seating position where the ‘*Seat*’ back is divided into two or more sections which may be folded independently of each other, and the division between two sections lies substantially along the ‘*Seating Reference Plane*’ of the middle seating position.

- 34.3.2.3. *‘Upper Anchorages’ or ‘Upper Anchor Fitting(s)’ may be installed in front seating positions other than the driver’s ‘Seat’.*

34.4. INFORMATION REQUIREMENTS

- 34.4.1. Information including either a photograph or a diagram regarding the location of each *‘Child Restraint Anchorage’* (if fitted), installation of *‘Upper Anchor Fittings’* (if applicable), and installation of *‘Child Restraint ‘Attaching Clips’* shall be specified in the vehicle handbook or otherwise supplied with the vehicle. The information shall include:

- 34.4.1.1. “WARNING: child restraint anchorages are designed to withstand only those loads imposed by correctly fitted child restraints. Under no circumstances are they to be used for adult seatbelts, harnesses, or for attaching other items or equipment to the vehicle.”

- 34.4.1.2. details on the length of bolts and the thickness (and number) of *‘Spacers’* required at each *‘Upper Anchorage’* (as applicable), location and correct method of installation and orientation of *‘Upper Anchor Fitting(s)’* (as applicable), and method of attachment and orientation of *‘Attaching Clip(s)’*. Orientation shall be shown relative to the front of the vehicle.

- 34.4.1.3. Details of the dedicated anchor fitting package in accordance with clauses 34.2.1.1.2, 34.2.1.2.2 and 34.2.1.4.1 and its location in the vehicle.

34.5. UPPER ANCHORAGE LOCATION REQUIREMENTS

- 34.5.1. Each *‘Upper Anchorage’* and *‘Upper Anchor Fitting’* must comply with clause 34.5.2 and clause 34.5.3, or comply with clause 34.5.4.

- 34.5.1.1. In addition, each *‘Upper Anchorage’* and *‘Upper Anchor Fitting’* shall be located within the vehicle in a part of the body structure which would not normally be movable, or if movable would not alter the tension in any *‘Upper Anchorage Strap’* when moved.

- 34.5.1.1.1. The requirements of clause 34.5.1.1 do not apply if the *‘Upper Anchorage’* and *‘Upper Anchor Fitting’* are located on a *‘Seat’*.

- 34.5.2. In the vertical plane, the entire *‘Interface Profile’* of each *‘Upper Anchor Fitting’* shall be located within the shaded area shown in Figure 6 with :

- 34.5.2.1. the *‘Manikin’* to be positioned in the *‘Seating Reference Plane’* when the *‘Seat’* and the *‘Seat’* back are in the design position;

- 34.5.2.2. the *‘Manikin’s’* *‘H Point’* at the *‘Seating Reference Point’*; and

- 34.5.2.3. the *‘Manikin’s’* *‘Torso Reference Line’* at the same angle from the vertical as the *‘Seat’* back.

- 34.5.3. In the horizontal plane, the centreline of the *‘Interface Profile’* of each *‘Upper Anchor Fitting’* shall lie within 40 mm of the *‘Seating Reference Plane’* of the seating position for which the *‘Upper Anchor Fitting’* is provided.

- 34.5.4. Subject to Clause 34.5.4.1, the entire *‘Interface Profile’* of each *‘Upper Anchor Fitting’* shall be located within the shaded zone shown in Figures

9 to 13. The zone is defined with reference to the '*Seating Reference Point*'. (For purposes of the figures, "H" Point is defined to mean '*Seating Reference Point*'.) The '*Interface Profile*' may be recessed in the seat back, provided that it is not in the strap wrap-around area at the top of the vehicle seat back. For the area under the vehicle seat, the forward most edge of the shaded zone is defined by the '*Torso Reference Line*'.

- 34.5.4.1. The '*Interface Profile*' may be located outside the shaded zone shown in Figures 9 to 13 if a location within that zone is not appropriate and the vehicle is equipped with a routing device that,
 - 34.5.4.1.1. ensures that the '*Upper Anchorage Strap*' functions as if the '*Interface Profile*' were located within the shaded zone; and,
 - 34.5.4.1.2. is at least 65 mm behind the '*Torso Reference Line*', in case of a non-rigid webbing-type routing device or a deployable routing device, or at least 100 mm behind the '*Torso Reference Line*', in the case of a fixed rigid routing device; and,
 - 34.5.4.1.3. when tested after being installed as it is intended to be used, the device is of sufficient strength to withstand, with the '*Upper Anchorage*', the strength requirements specified in Clause 34.7, excluding sub-clauses 34.7.2.1 and 34.7.2.2.

34.6. ACCESSIBILITY TO ENGAGE AN ATTACHING CLIP

- 34.6.1. Clearance shall be provided around each '*Upper Anchor Fitting*' to allow latching and unlatching, without the use of tools, of the '*Attaching Clip*' to the '*Upper Anchor Fitting*' when it is installed in the vehicle.
- 34.6.2. For guidance to vehicle manufacturers, the clearance parameters shown in Figure 8 are sufficient to demonstrate compliance with Clause 34.6.1.

34.7. STRENGTH OF UPPER ANCHORAGES

- 34.7.1. For each '*Upper Anchorage*', static or dynamic testing shall be conducted at the vehicle '*Manufacturer's*' choice either to clause 34.7.2 or clause 34.7.3 as applicable - using '*Upper Anchor Fitting(s)*' provided in accordance with clause 34.2.
 - 34.7.1.1. The static test load of 3.4 kN (clause 34.7.2) relates to the upper tether strap load of 7 kN in the dynamic test specified in Australian Standard AS 3629.3-1991 "Methods of Testing Child Restraints Part 3 Dynamic Testing of Upper Anchorage Components".
 - 34.7.2. Static Testing - All '*Upper Anchor Fittings*' shall be tested simultaneously when installed in the vehicle, and with the '*Seat*' or '*Seat*' back installed, by application of a test load of not less than 3.4 kN to each '*Upper Anchor Fitting*'.
 - 34.7.2.1. The direction of the test load shall be within 20° of the '*Design Line of Action*' of the '*Upper Anchor Fitting*' and not more than 5° to the left or right of the direction of the longitudinal axis of the vehicle.

- 34.7.2.2. Where the ‘*Design Line of Action*’ is determined by the ‘*Seat*’ or ‘*Seat*’ back, and the ‘*Upper Anchor Fitting*’ is located more than 100 mm below a horizontal plane tangential to the point on the top of the ‘*Seat*’ back longitudinally ‘*Forward*’ of the ‘*Upper Anchor Fitting*’ then, with the ‘*Seat*’ or ‘*Seat*’ back installed, the load shall be applied ‘*Forward*’ of the ‘*Seat*’ back and not more than 5° above or below the horizontal and not more than 5° to the left or right of the direction of the longitudinal axis of the vehicle.
- 34.7.2.3. Each ‘*Upper Anchorage*’ and ‘*Upper Anchor Fitting*’ shall be capable of supporting the test load for a period of not less than one second.
- 34.7.3. Dynamic Testing - All ‘*Upper Anchor Fittings*’ shall be tested simultaneously when installed in the test vehicle body, including the complete ‘*Rear Seat*’ assembly or ‘*Vehicle Rear Seat*’ assembly and with test dummies restrained in each seating position for which a ‘*Upper Anchor Fitting*’ is provided.
- 34.7.3.1. The test dummies shall each have a mass of not less than 21.4 kg or shall comply with the requirements described in technical drawings produced by the TNO (Research Institute for Road Vehicles) - Netherlands[#] for a ‘*50th Percentile 6 Year Old Child*’.
- 34.7.3.2. The test dummies shall be restrained using suitable ‘*Child Restraints*’ comprising load bearing material having an elongation of not more than 25% when subjected to a load of 11 kN, and providing for pelvic and upper torso restraint. Each pelvic restraint portion shall be attached to the ‘*Lap Anchorages*’ for the adult ‘*Seatbelt Assembly*’ for the relevant ‘*Seat*’. The upper torso restraint portion shall be attached to the ‘*Upper Anchor Fitting*’.
- 34.7.3.3. The pelvic and upper torso portions of the ‘*Child Restraints*’ shall be adjusted to eliminate slack.
- 34.7.3.4. The test rig shall have a mass of not less than 380 kg and shall meet the requirements of clause 34.7.3.5 for test rig calibration. It shall comprise trolley, the test vehicle body or part thereof, and the complete ‘*Vehicle Rear Seat*’ assembly.
- 34.7.3.5. In the case of calibration prior to ‘*Upper Anchor Fitting*’ testing, the test rig, to which a mass of not less than 21.4 kg times the number of seating positions for which a ‘*Upper Anchor Fitting*’ is provided is rigidly attached, when subject to a velocity change of not less than 49 km/h, shall achieve within 30 milliseconds a forward deceleration measured in the vicinity of the corresponding ‘*Lap Anchorage*’ within the range of 235 m/s² to 335 m/s² and shall maintain this deceleration, except for periods of less than one millisecond, for not less than 20 milliseconds.
- 34.7.3.6. For ‘*Upper Anchor Fitting*’ testing, the test rig shall be operated in a manner identical in all operational aspects to that specified in clause 34.7.3.5 for rig calibration except that in this case the test dummies

[#] TNO address: Schoemaker Straat, 97; 2628 VK Delft, Netherlands.

replace the inert mass. The test dummies shall be restrained in accordance with the requirements of clause 34.7.3.2.

- 34.7.3.7. Each ‘*Upper Anchorage*’ and ‘*Upper Anchor Fitting*’ shall withstand the loads imposed when tested in accordance with the dynamic test requirements of clause 34.7.3.6.

34.8. REQUIREMENTS FOR ISOFIX ANCHORAGES

- 34.8.1. In addition to the requirements of clauses 34.2 to 34.7, where a vehicle includes any lower anchorage, which can be engaged by the ISOFIX attachment connectors of any one of the child restraint fixtures (CRFs) defined in Appendix A of ADR 4/... on a vehicle seat:
- 34.8.1.1. each lower anchorage provided must form part of an ISOFIX anchorages system.
- 34.8.2. Except for convertible vehicles²:
- 34.8.2.1. each ISOFIX position must be equipped with an ISOFIX anchorages system and an ISOFIX top tether anchorage (a “universal” ISOFIX position); and
- 34.8.2.2. each ISOFIX anchorages system and each ISOFIX top tether anchorage must meet the requirements of Appendix 1 of this standard.
- 34.8.3. For convertible vehicles:
- 34.8.3.1. the ISOFIX low anchorages of each ISOFIX anchorages system must meet the requirements of Appendix 2 of this standard; and
- 34.8.3.2. an ‘*Upper Anchorage*’ and an installed ‘*Upper Anchor Fitting*’ must be provided for each designated seating position on which an "ISO/F2" or "ISO/F2X" CRF (see Appendix A of ADR 4/...) can be attached to the ISOFIX low anchorages; in which case
- 34.8.3.2.1. the installed ‘*Upper Anchor Fitting*’ need only comply with Figure 2 in relation to the location and clearance of the ‘*Upper Anchor Fitting*’ ‘*Interface Profile*’.
- 34.8.4. For the purposes of this standard:
- 34.8.4.1. the portion of an ISOFIX top tether anchorage that is designed to bind with a ‘*Child Restraint*’ ‘*Attaching Clip*’ is deemed to be an ‘*Upper Anchor Fitting*’ ‘*Interface Profile*’, and is subject to the requirements for ‘*Upper Anchor Fittings*’ in this standard; and
- 34.8.4.2. an ISOFIX top tether anchorage is deemed to be an ‘*Upper Anchorage*’ and is subject to the requirements for ‘*Upper Anchorages*’ in this standard.
- 34.8.5. Each ISOFIX top tether anchorage must also meet the information, location, accessibility and strength requirements of clauses 34.4 to 34.7 of this standard.

² convertible vehicles are defined as per annex 7, paragraph 8.1. of the Consolidated Resolution on the Construction of Vehicles (R.E.3) – (Document TRANS/WP29/78/Rev.1/Amend.2)



- 34.8.6. Where ISOFIX positions are provided, information regarding the location of the ISOFIX low anchorages must be provided in the vehicle handbook or otherwise supplied with the vehicle.

34.9. ALTERNATIVE STANDARDS

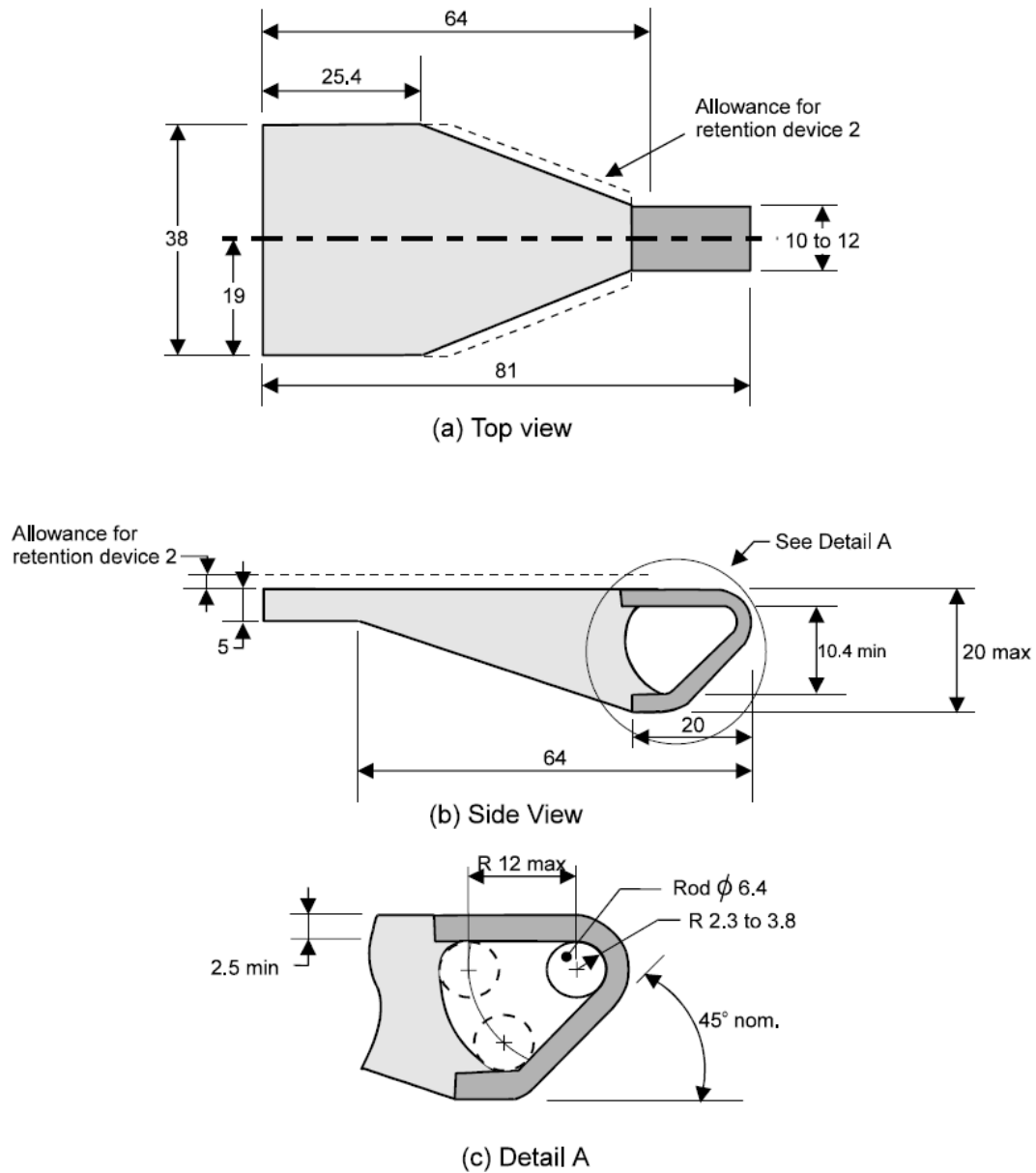
- 34.9.1. Where a vehicle manufacturer elects to incorporate a specific vehicle child restraint in a vehicle, it must comply with the relevant general and particular technical specifications of United Nations Economic Commission for Europe Regulation (UNECE) No. 44 UNIFORM PROVISIONS CONCERNING THE APPROVAL OF RESTRAINING DEVICES FOR CHILD OCCUPANTS OF POWER-DRIVEN VEHICLES ("CHILD RESTRAINT SYSTEM"), incorporating the 04 series of amendments, provided;
- 34.9.1.1. the restraint is of the type corresponding to a forward facing booster cushion which utilises the existing lap/sash seatbelt to restrain the child occupant.
- 34.9.2. The technical requirements adopted by the United Nations - Economic Commission for Europe Regulation No. 16 – UNIFORM PROVISIONS CONCERNING THE APPROVAL OF: I. SAFETY-BELTS, RESTRAINT SYSTEMS, CHILD RESTRAINT SYSTEMS AND ISOFIX CHILD RESTRAINT SYSTEMS FOR OCCUPANTS OF POWER-DRIVEN VEHICLES and II. VEHICLES EQUIPPED WITH SAFETY-BELTS, RESTRAINT SYSTEMS, CHILD RESTRAINT SYSTEMS AND ISOFIX CHILD RESTRAINT SYSTEMS, incorporating the 06 series of amendments shall be deemed to be equivalent to Appendix A of ADR 4/... for the purposes of the definition of a child restraint fixture (CRF) under clause 34.8.1 and clause 34.8.3.2 of this standard.
- 34.9.3. The technical requirements adopted by the United Nations - Economic Commission for Europe Regulation No. 14 – UNIFORM PROVISIONS CONCERNING THE APPROVAL OF VEHICLES WITH REGARD TO SAFETY-BELT ANCHORAGES, ISOFIX ANCHORAGES SYSTEMS AND ISOFIX TOP TETHER ANCHORAGES, incorporating the 07 series of amendments, shall be deemed to be equivalent to Appendix 1 of this standard.
- 34.9.4. The technical requirements adopted by the United Nations - Economic Commission for Europe Regulation No. 14 – UNIFORM PROVISIONS CONCERNING THE APPROVAL OF VEHICLES WITH REGARD TO SAFETY-BELT ANCHORAGES, ISOFIX ANCHORAGES SYSTEMS AND ISOFIX TOP TETHER ANCHORAGES, incorporating the 07 series of amendments, shall be deemed to be equivalent to Appendix 2 of this standard.



Legend



-  Maximum unobstructed area in which the 'Upper Anchor Fitting' 'Interface Profile' can move.
-  Surrounding structure (if present).
-  Area in which the child restraint 'Attaching Clip' 'Interface Profile' must be wholly located.

Dimensions in millimetres
(not to scale)

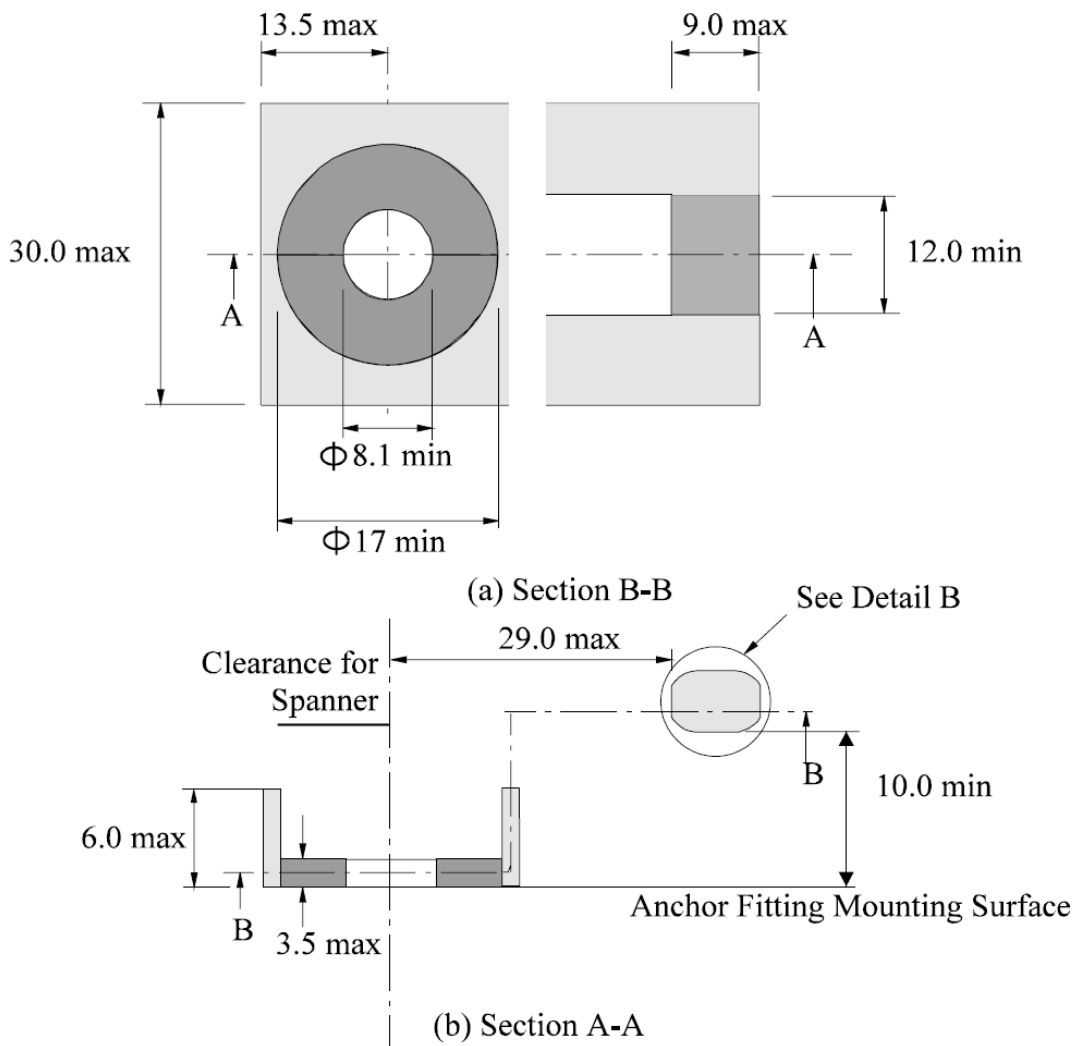
FIGURE 1 'ATTACHING CLIP' PROFILE

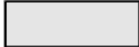

Legend

-  Surrounding structure (if present).
-  Area in which the 'Upper Anchor Fitting' 'Interface Profile' must be wholly located.
-  Area in which the mounting face must be wholly located.

Dimensions in mm
(not to scale)

FIGURE 2: 'UPPER ANCHOR FITTING' PROFILE

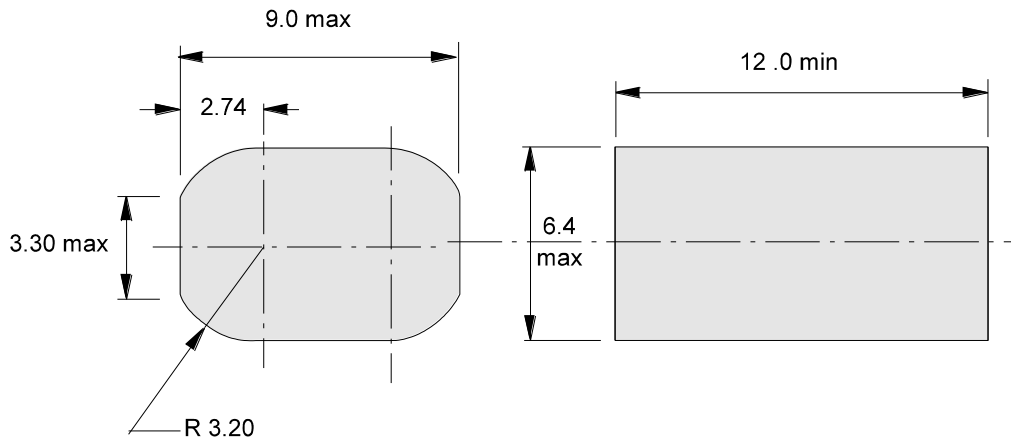

(c) Detail B

NOTE:

1 Profile may be round, oblong or combination of both provided it remains within the shaded areas shown.

2 Detail B can rotate about its longitudinal axis

FIGURE 2(C): ANCHOR FITTING ‘INTERFACE PROFILE’

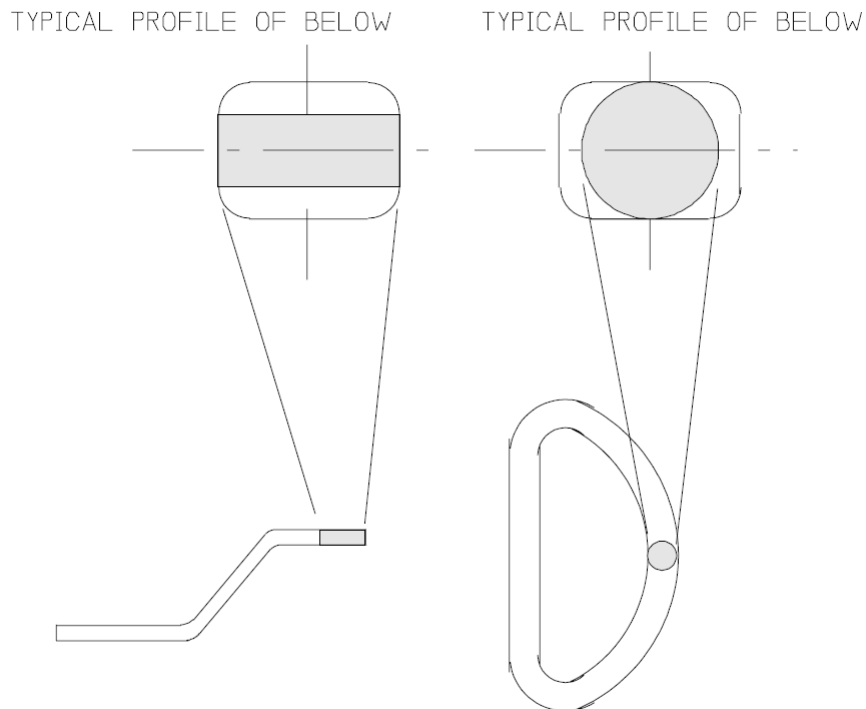

(a) Profile A fitting

(b) Profile B fitting

Dimensions in mm (not to scale)

FIGURE 3: TYPICAL ANCHOR FITTING ‘INTERFACE PROFILES’

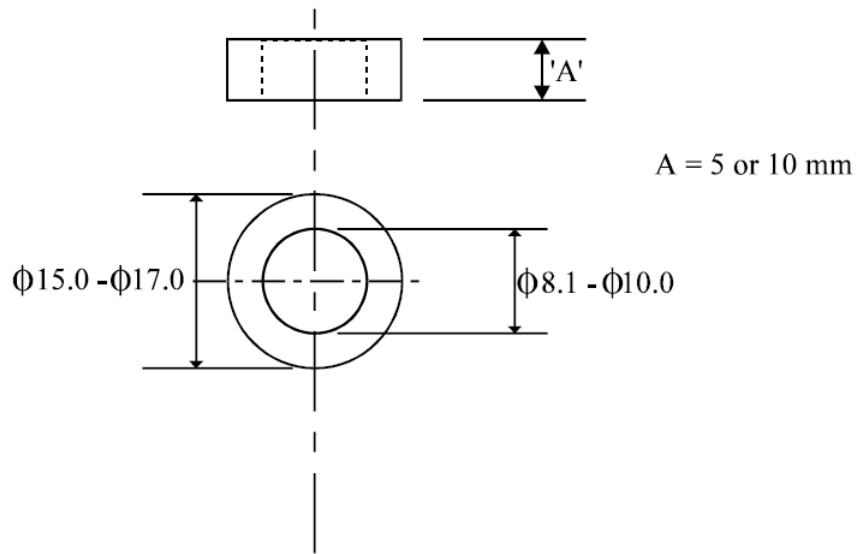

Dimensions in millimetres (not to scale)

FIGURE 4 'SPACER'

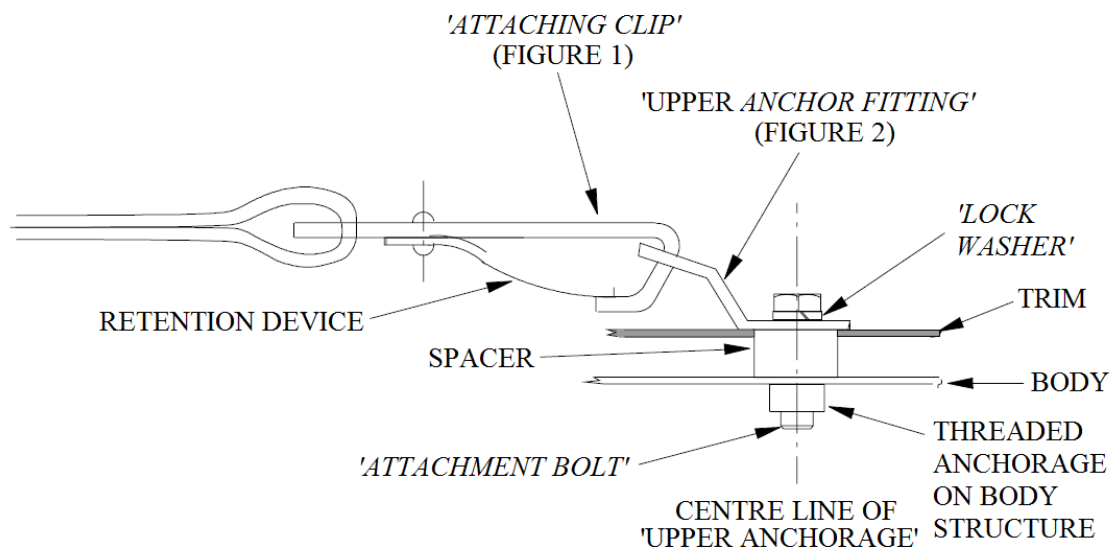

FIGURE 5: A TYPICAL 'UPPER ANCHORAGE' ASSEMBLY IN THE VEHICLE

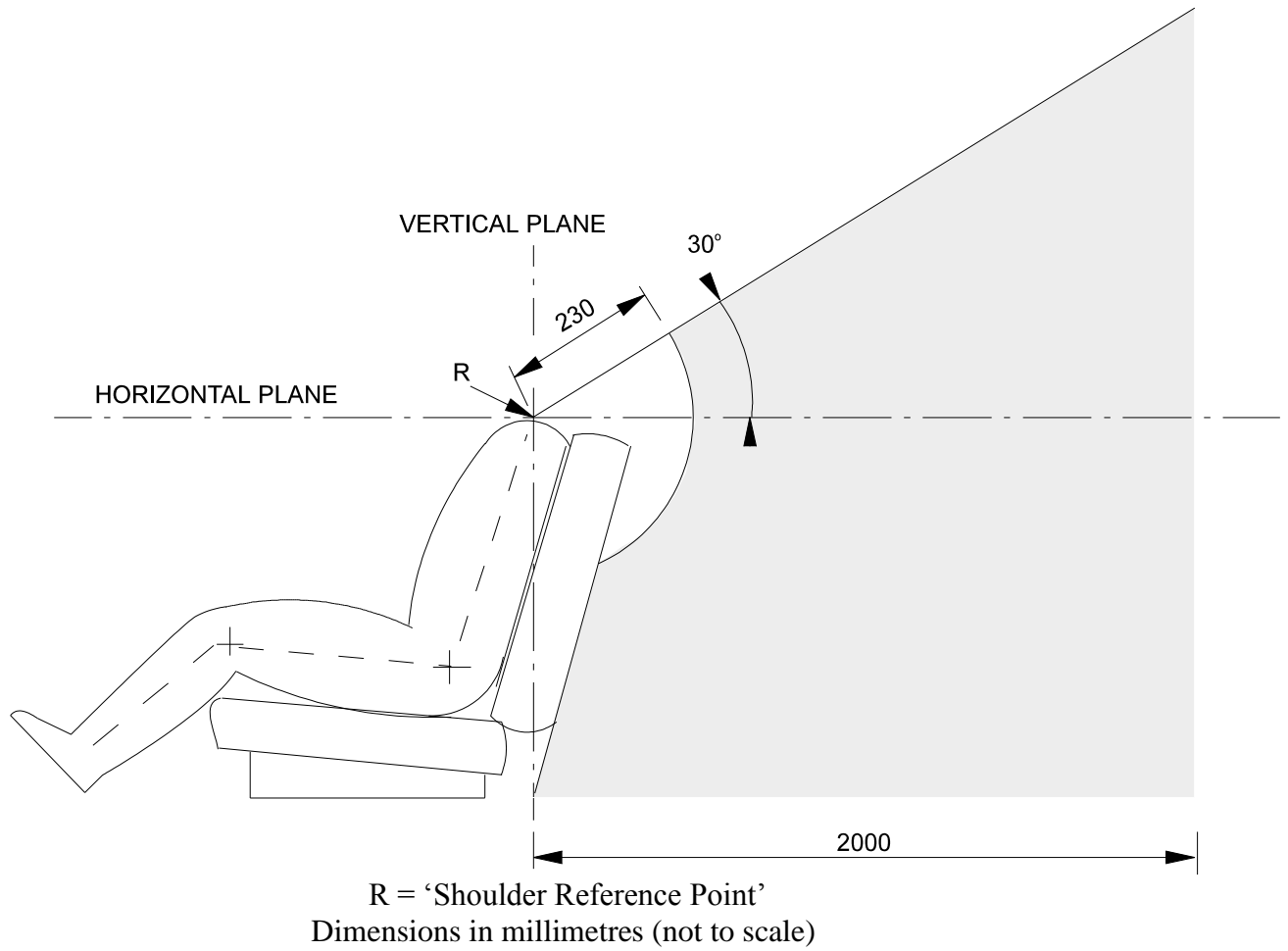
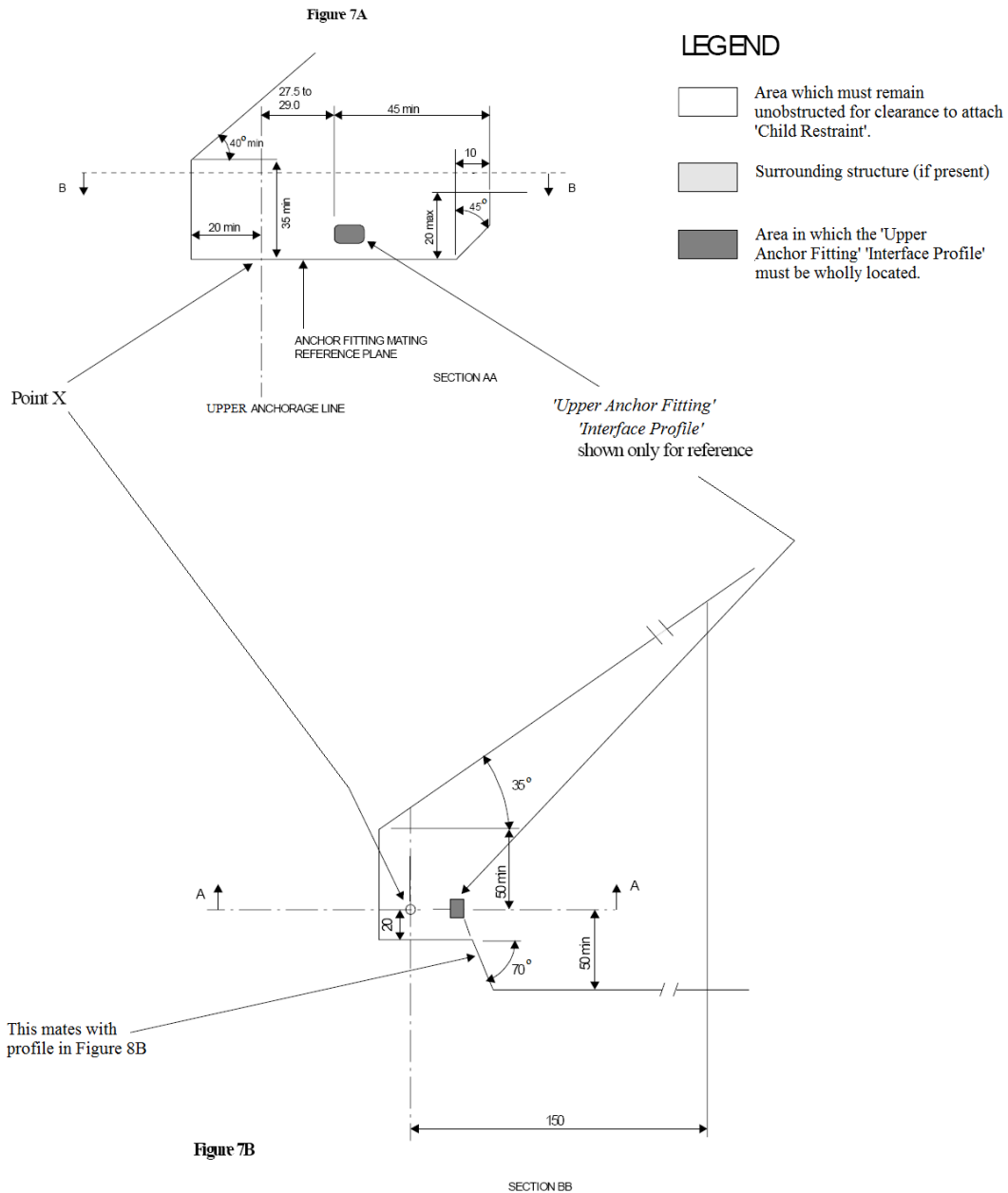

FIGURE 6: SIDE VIEW - 'UPPER ANCHOR FITTING' 'INTERFACE PROFILE' LOCATION



Notes:

1. The specified arc allows for room to manipulate a spanner to tighten the 'Attachment Bolt'.
2. Each view can be rotated about an axis passing through point X and perpendicular to the page.
3. Dimensions in mm except where otherwise indicated.
4. Drawing not to scale.

FIGURE 7: CLEARANCE SPACE REQUIRED WHERE ANCHORAGE ONLY IS PROVIDED

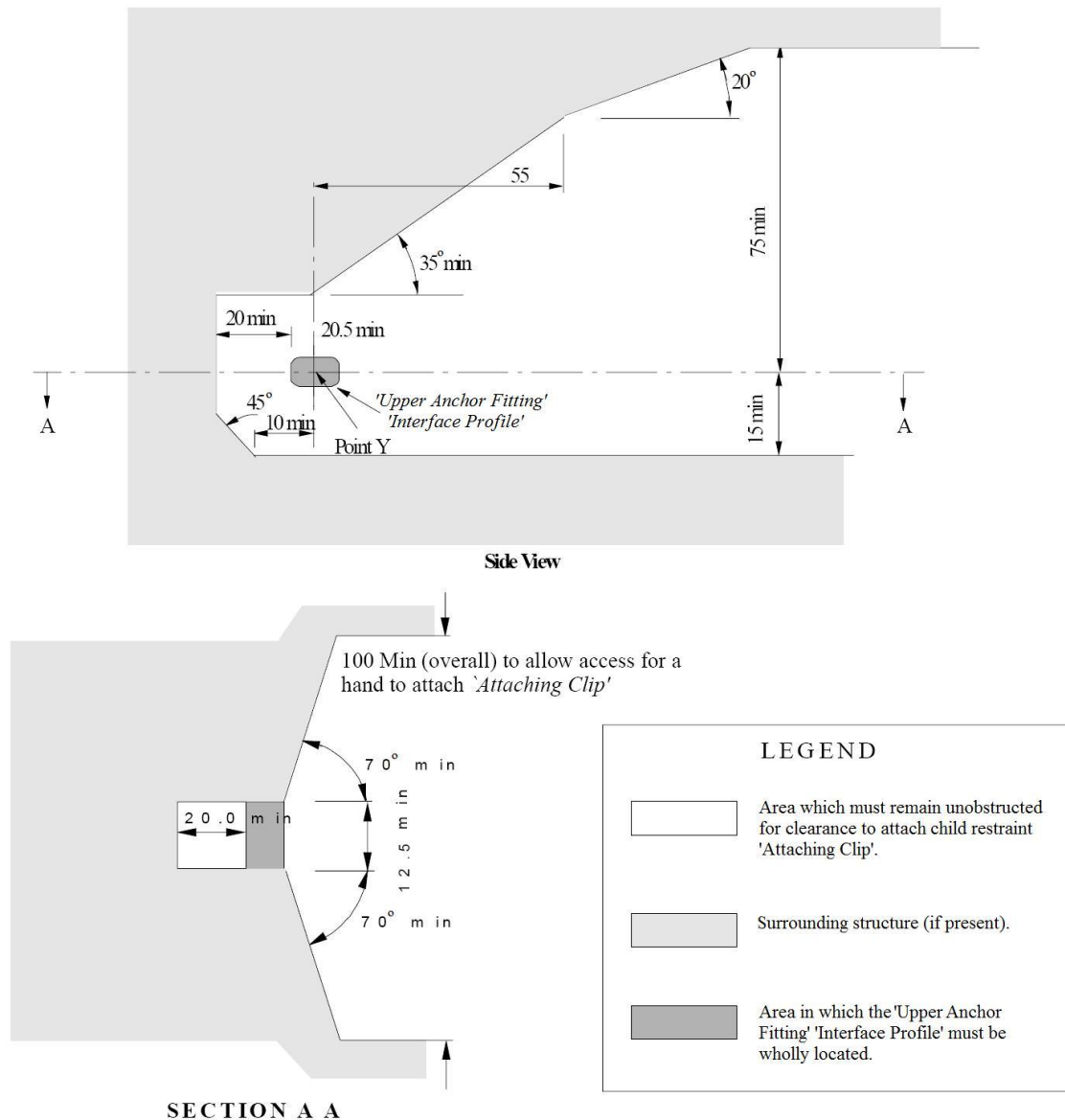

Notes:

1. Where the 'Upper Anchor Fitting' is adjustable it must comply with the requirements as shown in these illustrations in at least one position of adjustment.
2. If not adjustable, the side view may be rotated about an axis passing through Point Y and perpendicular to the page.
3. Dimensions in mm except where otherwise indicated.
4. Drawing not to scale.

FIGURE 8: CLEARANCE AROUND 'UPPER ANCHOR FITTINGS'

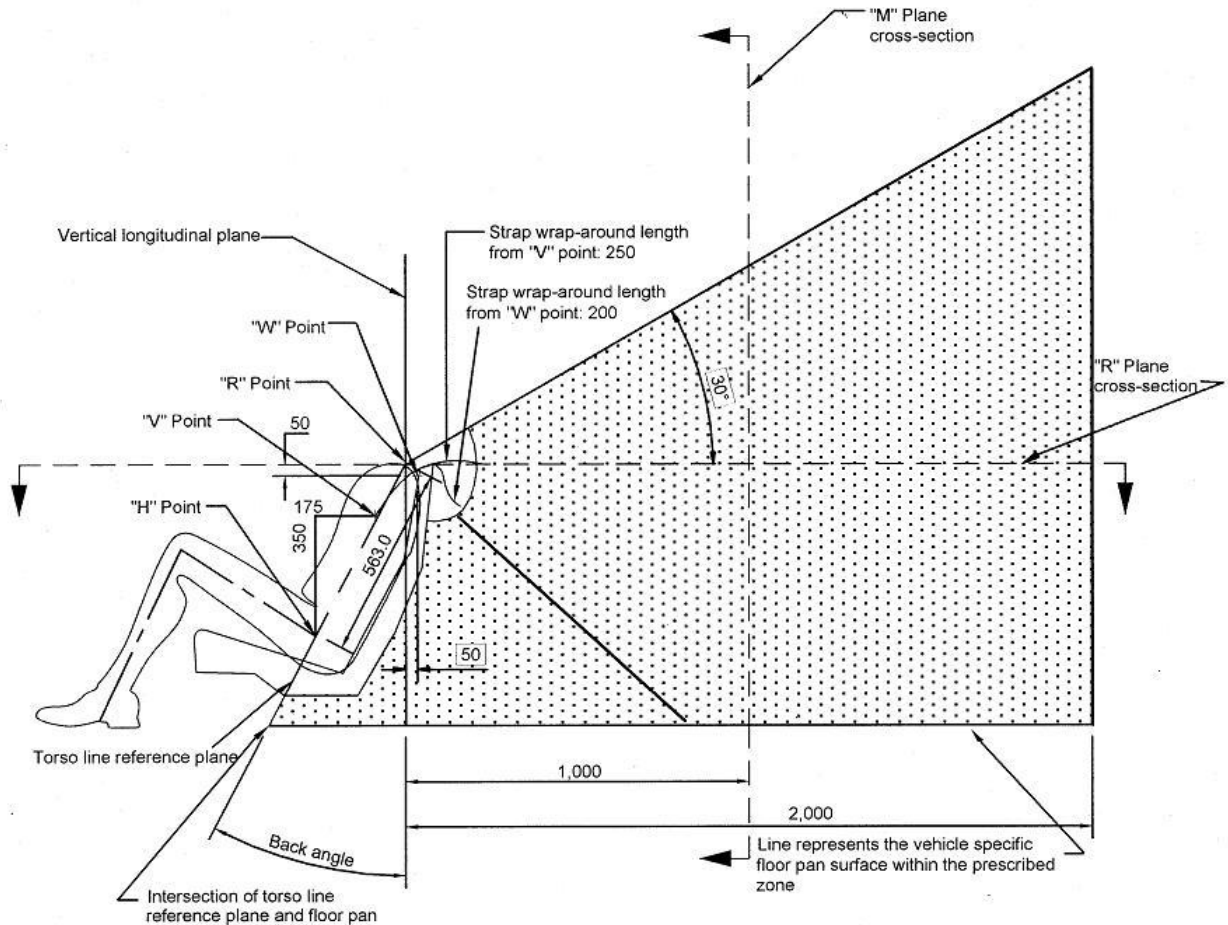

Notes:

1. Dimensions in mm except where otherwise indicated.
2. 'Upper Anchor Fitting' 'Interface Profile' to be located within shaded zone.
3. Drawing not to scale.
4. "R" Point: Shoulder reference point.
5. "V" Point: V-reference point, 350 mm vertically above and 175 mm horizontally back from H-point.
6. "W" Point: W-reference point, 50 mm vertically below and 50 mm horizontally back from "R" Point.
7. M Plane: M-reference plane, 1000 mm horizontally back from "R" Point.

FIGURE 9: SIDE VIEW OF 'UPPER ANCHOR FITTING' 'INTERFACE PROFILE' ZONE

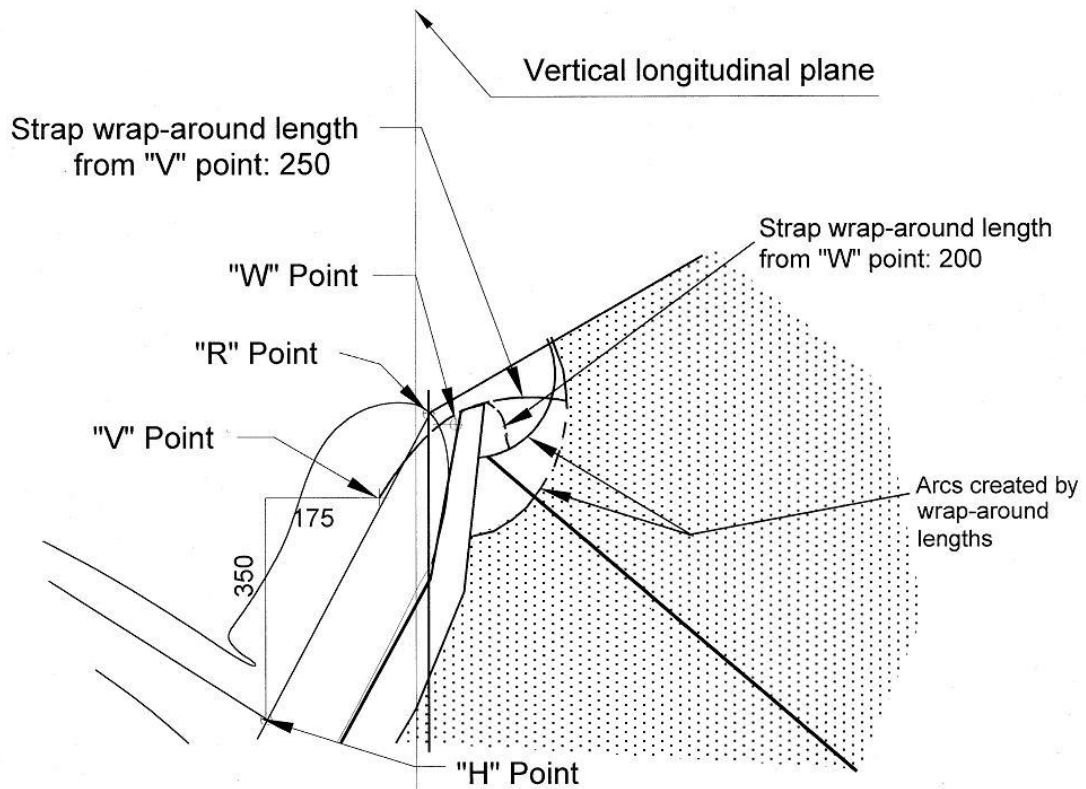

Notes:

1. Dimensions in mm except where otherwise indicated.
2. 'Upper Anchor Fitting' 'Interface Profile' to be located within shaded zone.
3. Drawing not to scale.
4. "R" Point: Shoulder reference point.
5. "V" Point: V-reference point, 350 mm vertically above and 175 mm horizontally back from H-point.
6. "W" Point: W-reference point, 50 mm vertically below and 50 mm horizontally back from "R" Point.

FIGURE 10: ENLARGED SIDE VIEW OF STRAP WRAP AROUND AREA OF 'UPPER ANCHOR FITTING' 'INTERFACE PROFILE' ZONE

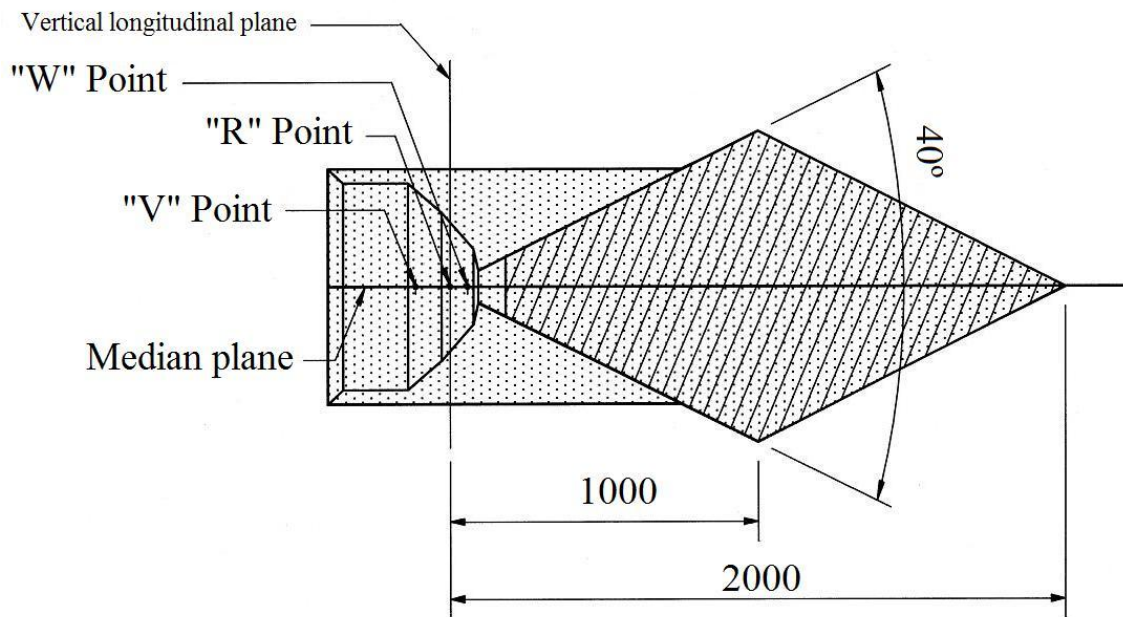

Notes:

1. Dimensions in mm except where otherwise indicated.
2. 'Upper Anchor Fitting' 'Interface Profile' to be located within shaded zone.
3. Drawing not to scale.
4. "R" Point: Shoulder reference point.
5. "V" Point: V-reference point, 350 mm vertically above and 175 mm horizontally back from H-point.
6. "W" Point: W-reference point, 50 mm vertically below and 50 mm horizontally back from "R" Point.

FIGURE 11: PLAN VIEW (R-PLANE CROSS SECTION) OF 'UPPER ANCHOR FITTING' 'INTERFACE PROFILE' ZONE

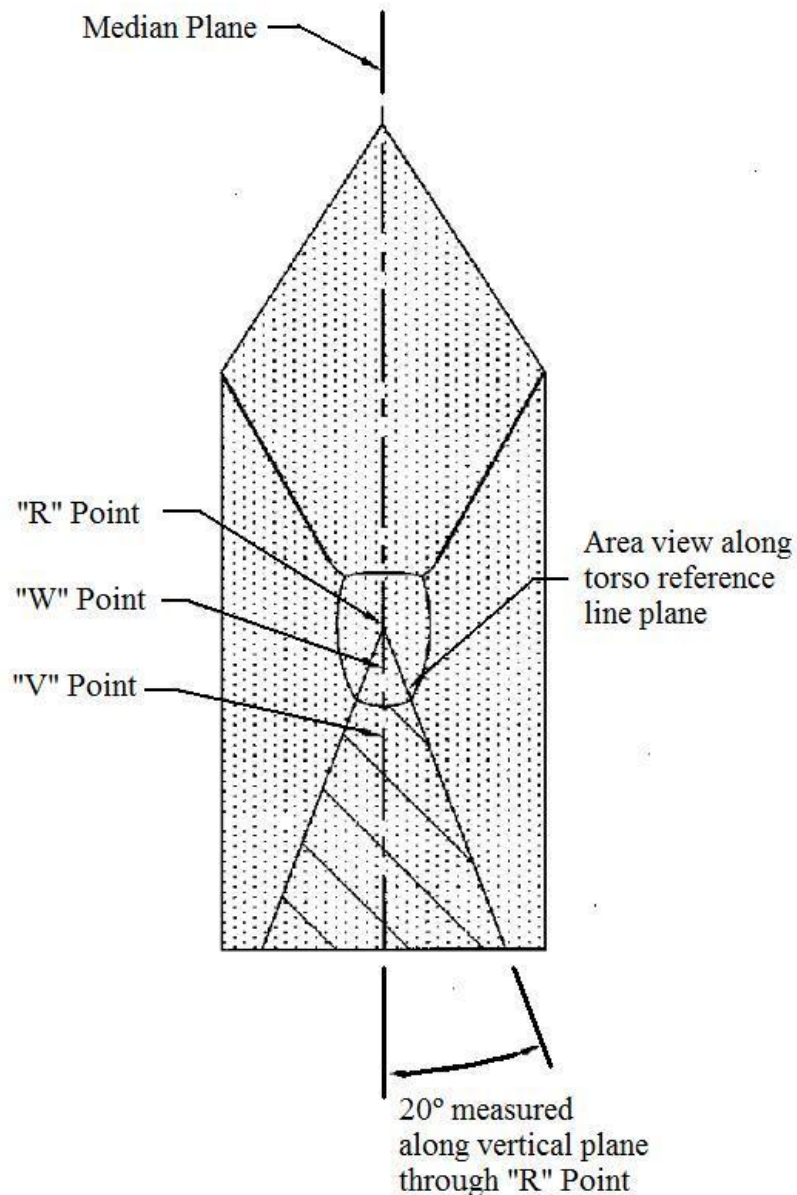

Notes:

1. 'Upper Anchor Fitting' 'Interface Profile' to be located within shaded zone.
2. Drawing not to scale.
3. "R" Point: Shoulder reference point.
4. "V" Point: V-reference point, 350 mm vertically above and 175 mm horizontally back from H-point.
5. "W" Point: W-reference point, 50 mm vertically below and 50 mm horizontally back from "R" Point.

FIGURE 12: FRONT VIEW OF 'UPPER ANCHOR FITTING' 'INTERFACE PROFILE' ZONE

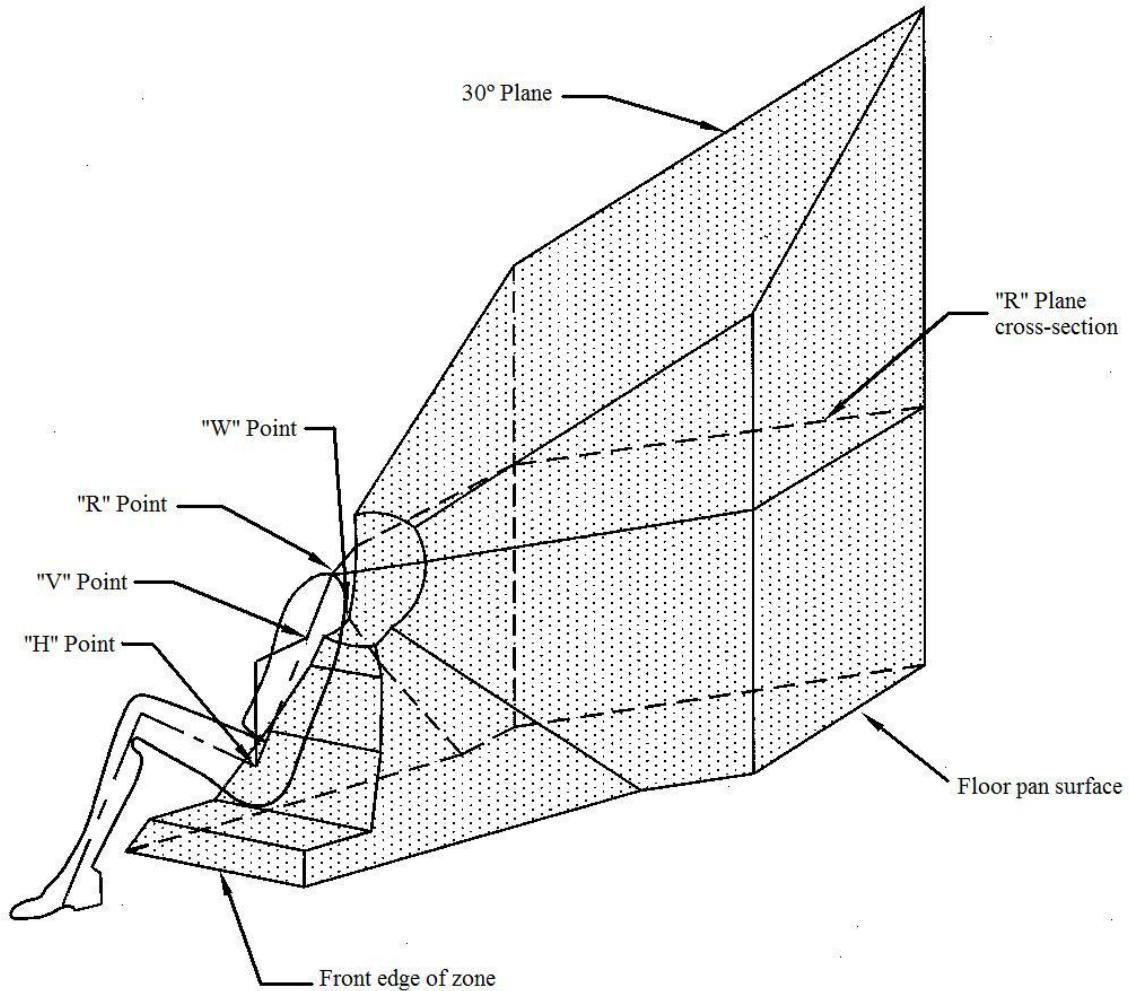

Notes:

1. 'Upper Anchor Fitting' 'Interface Profile' to be located within shaded zone.
2. Drawing not to scale.
3. "R" Point: Shoulder reference point.
4. "V" Point: V-reference point, 350 mm vertically above and 175 mm horizontally back from H-point.
5. "W" Point: W-reference point, 50 mm vertically below and 50 mm horizontally back from "R" Point.

FIGURE 13: 3-DIMENSIONAL ISOMETRIC VIEW OF 'UPPER ANCHOR FITTING' 'INTERFACE PROFILE' ZONE

APPENDIX 1

ISOFIX ANCHORAGES SYSTEM AND ISOFIX TOP TETHER ANCHORAGE REQUIREMENTS (EXCEPT FOR CONVERTIBLE VEHICLES)

1. Where ISOFIX low anchorages and ISOFIX top tether anchorages are provided in vehicles in accordance with clause 34.8.2 of this standard:
 - 1.1. each ISOFIX anchorages system and each ISOFIX top tether anchorage must meet the technical requirements of Appendix A of ADR 5/... except that:
 - 1.1.1. vehicles need not be equipped with a particular number of ISOFIX positions; and
 - 1.1.2. any reference to test forces of “5 kN ± 0.25 kN” or “8 kN ± 0.25 kN” may be read as “at least 5 kN” and “at least 8 kN” respectively; and
 - 1.1.3. any requirement for “a tension pre-load of 50 N ± 5 N” to be applied between the SFAD and an ISOFIX top tether anchorage may be read as “a tension pre-load of 45 N to 67 N”; and
 - 1.1.4. any requirement for full application of test forces to be “achieved within a period of 2 s or less” may be read as “achieved in not less than 24 seconds and not more than 30 seconds”, when the applicable test force is also sustained for a period of at least 1 second.

APPENDIX 2

ISOFIX ANCHORAGES SYSTEM REQUIREMENTS FOR CONVERTIBLE VEHICLES

2. Where ISOFIX low anchorages are provided in convertible vehicles in accordance with clause 34.8.3 of this standard:
 - 2.1. the ISOFIX low anchorages of each ISOFIX anchorages system must meet the technical requirements of Appendix A of ADR 5/... except that:
 - 2.1.1. convertible vehicles need not be equipped with a particular number of ISOFIX positions; and
 - 2.1.2. any reference to test forces of “5 kN ± 0.25 kN” or “8 kN ± 0.25 kN” may be read as “at least 5 kN” and “at least 8 kN” respectively; and
 - 2.1.3. any requirement for full application of test forces to be “achieved within a period of 2 s or less” may be read as “achieved in not less than 24 seconds and not more than 30 seconds”, when the applicable test force is also sustained for a period of at least 1 second.