

# **APPENDIX 4 - MANAGING ELECTRICAL RISKS IN THE WORKPLACE**

## **Code of Practice**

# TABLE OF CONTENTS

<b>FOREWORD</b> .....	<b>3</b>
SCOPE AND APPLICATION .....	3
<b>INTRODUCTION</b> .....	<b>6</b>
1.1 What are electrical risks? .....	6
1.2 Who must manage electrical risks? .....	6
1.3 What is required to manage electrical risks?.....	8
<b>2. THE RISK MANAGEMENT PROCESS</b> .....	<b>12</b>
2.1 Identify the hazards .....	12
2.2 Assess the risks .....	13
2.3 Control the risks .....	14
2.4 Review the control measures.....	15
<b>3. SPECIFIC HAZARDS AND RISK CONTROL</b> .....	<b>16</b>
3.1 Unsafe electrical equipment and electrical installations at the workplace .....	16
3.2 Inspecting and testing electrical equipment.....	17
3.3 Inspecting and testing equipment – construction and demolition sites	23
3.4 Residual current devices (RCDs) .....	23
<b>4. MANAGING THE RISKS OF ELECTRICAL WORK</b> .....	<b>30</b>
4.1 What is electrical work? .....	30
4.2 Identify the hazards .....	31
4.3 Assess the risks .....	31
4.4 Control the risks .....	33
4.5 Review the control measures.....	34
<b>5. RISK CONTROLS – WORKING DE-ENERGISED</b> .....	<b>35</b>
5.2 General principles – verification of de-energised electrical equipment .	35
5.3 Safe work method statements .....	36
5.4 Work on cables (including cutting cables) .....	36
<b>6. LOW VOLTAGE ISOLATION AND ACCESS</b> .....	<b>38</b>
6.1 Securing the isolation .....	39
6.2 Altering isolation for testing, fault finding and re-energising .....	43
6.3 Restoring power .....	44
6.4 Leaving unfinished work .....	44
<b>7. RISK CONTROLS – ENERGISED ELECTRICAL WORK</b> .....	<b>46</b>

7.1 Prohibition on energised electrical work .....	46
7.2 Planning and preparation .....	47
7.3 Carrying out energised electrical work .....	49
7.4 Leaving unfinished work .....	54
7.5 Particular energised electrical work—testing and fault finding .....	55
<b>8. RISK CONTROLS – WORKING NEAR ENERGISED ELECTRICAL PARTS</b> .....	<b>56</b>
8.1 Planning and preparation .....	56
8.2 Working near energised electrical parts .....	57
8.3 Implementing risk control measures.....	58
8.4 Reviewing risk control measures .....	58
<b>9. TOOLS AND EQUIPMENT .....</b>	<b>59</b>
9.1 Inspection and testing .....	59
9.2 Ladders, scaffolds and similar equipment .....	59
9.3 Insulating barriers and insulating mats .....	60
9.4 Test instruments.....	61
9.5 Personal protective equipment (PPE) .....	63
9.6 First Aid.....	63
<b>10. HIGH VOLTAGE ELECTRICAL WORK .....</b>	<b>65</b>
<b>APPENDIX A – MEANING OF KEY TERMS.....</b>	<b>67</b>
<b>APPENDIX B – ADVANTAGES AND DISADVANTAGES OF NON- PORTABLE AND PORTABLE RCDS .....</b>	<b>69</b>
<b>APPENDIX C – RISKS ASSOCIATED WITH ELECTRICAL WORK .....</b>	<b>74</b>
<b>APPENDIX D – PREVENTATIVE ACTIONS CHECKLIST .....</b>	<b>85</b>

## **FOREWORD**

This Code of Practice on how to manage electrical risks in workplaces is an approved code of practice under section 274 of the Work Health and Safety Act (the WHS Act).

An approved code of practice is a practical guide to achieving the standards of health, safety and welfare required under the WHS Act and the Work Health and Safety Regulations (the WHS Regulations).

A code of practice applies to anyone who has a duty of care in the circumstances described in the code. In most cases, following an approved code of practice would achieve compliance with the health and safety duties in the WHS Act, in relation to the subject matter of the code. Like regulations, codes of practice deal with particular issues and do not cover all hazards or risks that may arise. The health and safety duties require duty holders to consider all risks associated with work, not only those for which regulations and codes of practice exist.

Codes of practice are admissible in court proceedings under the WHS Act and Regulations. Courts may regard a code of practice as evidence of what is known about a hazard, risk or control and may rely on the code in determining what is reasonably practicable in the circumstances to which the code relates.

Compliance with the WHS Act and Regulations may be achieved by following another method, such as a technical or an industry standard, if it provides an equivalent or higher standard of work health and safety than the code.

An inspector may refer to an approved code of practice when issuing an improvement or prohibition notice.

This Code of Practice is based on the draft developed as a model code of practice under the Council of Australian Governments' Inter-Governmental Agreement for Regulatory and Operational Reform in Occupational Health and Safety for adoption by the Commonwealth, state and territory governments.

## **SCOPE AND APPLICATION**

This Code provides practical guidance for persons conducting a business or undertaking on managing electrical risks in the workplace. It applies to all workplaces where a person conducting a business or undertaking:

- has management or control of electrical equipment, including electrical installations, or
- carries out electrical work on or near energised electrical equipment, including electrical installations.

This Code also applies to construction and demolition sites, except if a requirement of the Code is dealt with in AS/NZS 3012:2010 *Electrical installations—Construction and demolition sites*. In that case you must comply with AS/NZS 3012:2010. Further information about construction work can be found in the *Code of Practice: Construction Work*.

This Code does not apply to:

- electrical work on extra-low voltage electrical equipment, including extra-low voltage electrical installations
- electrical work on high voltage equipment after switching, isolation, short circuiting and earthing, subject to summary guidance in Chapter 10 of this Code
- the manufacture of electrical equipment
- automotive electrical work
- work that is not electrical work carried out on telephone, communication and data systems
- work carried out by or on behalf of an electricity supply authority on the electrical equipment controlled or operated by the authority to generate, transform, transmit or supply electricity
- repair of consumer electrical equipment when unplugged from any electrical socket outlet.

'Extra-low voltage' means voltage that does not exceed 50 volts alternating current (50 V a.c.) or 120 volts ripple-free direct current (120 V ripple free d.c.).

This Code is divided into two parts dealing with:

- Part A (*Chapters 2-3*): general electrical safety at the workplace, including electrical installations, requirements for inspecting and testing electrical equipment, and requirements for residual current devices in certain high-risk environments
- Part B (*Chapters 4-9*): health and safety risks associated with electrical work.

## **HOW TO USE THIS CODE OF PRACTICE**

In providing guidance, the word 'should' is used in this Code to indicate a recommended course of action, while 'may' is used to indicate an optional course of action.

This Code also includes various references to provisions of the WHS Act and Regulations which set out the legal requirements. These references are not exhaustive. The words 'must', 'requires'

or 'mandatory' indicate that a legal requirement exists and must be complied with.

# INTRODUCTION

## 1.1 WHAT ARE ELECTRICAL RISKS?

Electrical risks are risks of death, electric shock or other injury caused directly or indirectly by electricity. The most common electrical risks and causes of injury are:

- electric shock causing injury or death. The electric shock may be received by direct or indirect contact, tracking through or across a medium, or by arcing. For example, electric shock may result from indirect contact where a conductive part that is not normally energised becomes energised due to a fault (e.g. metal toaster body, fence)
- arcing, explosion or fire causing burns. The injuries are often suffered because arcing or explosion or both occur when high fault currents are present
- electric shock from 'step-and-touch' potentials
- toxic gases causing illness or death. Burning and arcing associated with electrical equipment may release various gases and contaminants
- fire resulting from an electrical fault.

Even the briefest contact with electricity at 50 volts for alternating current (V a.c.) or 120 volts for direct current (V d.c.) can have serious consequences to a person's health and safety. High voltage shocks involving more than 1000 V a.c. or 1500 V d.c. can cause contact burns and damage to internal organs.

Electric shocks from faulty electrical equipment may also lead to related injuries, including falls from ladders, scaffolds or other elevated work platforms. Other injuries or illnesses may include muscle spasms, palpitations, nausea, vomiting, collapse and unconsciousness.

Workers using electricity may not be the only ones at risk—faulty electrical equipment and poor electrical installations can lead to fires that may also cause death or injury to others.

Key terms used in this Code are defined at Appendix A.

## 1.2 WHO MUST MANAGE ELECTRICAL RISKS?

A **person conducting a business or undertaking** has the primary duty under the WHS Act to ensure, so far as is reasonably practicable, that workers and other persons at the workplace are not exposed to electrical risks arising from the business or undertaking. This duty requires eliminating electrical risks or, if that is not reasonably practicable, minimising the risks so far as is reasonably practicable.

The WHS Regulations include more specific requirements for managing electrical risks at the workplace. For example, all persons conducting a business or undertaking have duties to ensure, so far as is reasonably practicable, that electrical equipment and installations at the workplace are without risks to health and safety of persons.

Persons conducting a business or undertaking with management or control of a workplace have a duty to ensure effective residual current devices (RCDs) are used in certain high-risk environments as defined in the regulations.

Persons conducting a business or undertaking carrying out electrical work must comply with the prohibition on electrical work on energised electrical equipment subject to certain exceptions. These persons may also have duties under local electrical safety laws.

Persons conducting a business or undertaking should ensure electrical installation work is carried out by qualified persons and testing and compliance requirements are met.

**Designers, manufacturers, importers, suppliers, and installers** of electrical equipment and installations that could be used for work must ensure, so far as is reasonably practicable, that they are without risks to health and safety. Designers and manufacturers of electrical equipment or installations must ensure they are designed and manufactured so that electrical risks are eliminated or, if this not reasonably practicable, minimised so far as is reasonably practicable.

**Officers**, such as company directors, have a duty to exercise due diligence to ensure that the business or undertaking complies with the WHS Act and Regulations. This includes taking reasonable steps to ensure that the business or undertaking has and uses appropriate resources and processes to eliminate or minimise electrical risks at the workplace.

**Workers** must take reasonable care for their own health and safety and not adversely affect the health and safety of other persons. Workers must comply with any reasonable instruction and cooperate with any reasonable policy or procedure relating to health and safety at the workplace. This means that if electrical equipment is provided by the person conducting the business or undertaking, the worker must use it in accordance with the information, instruction and training provided on its use.

**Duty holders** may have additional legal obligations under state or territory electrical safety legislation.



### 1.3 WHAT IS REQUIRED TO MANAGE ELECTRICAL RISKS?

**Regulation 147** A person conducting a business or undertaking must manage risks to health and safety associated with electrical risks at the workplace.

**Regulations 34-38** In order to manage risk under the WHS Regulations, a duty holder must:

- identify reasonably foreseeable hazards that could give rise to the risk
- eliminate the risk, so far as is reasonably practicable
- if it is not reasonably practicable to eliminate the risk, minimise the risk so far as is reasonably practicable by implementing control measures
- maintain the implemented control measure so that it remains effective
- review, and if necessary revise, all risk control measures so as to maintain, so far as is reasonably practicable, a work environment that is without risks to health and safety.

The hierarchy of risk control is described at Section 0 of this Code.

This Code includes guidance on how to manage electrical risks in the workplace by following a systematic process that involves:

- identifying hazards
- if necessary, assessing the risks associated with these hazards
- implementing and maintaining risk control measures (e.g. inspecting and testing electrical equipment, using RCDs), and
- reviewing risk control measures.

Guidance on the general risk management process is available in the Code of Practice: How to Manage Work Health and Safety Risks.

#### ***Consulting your workers***

Consultation involves sharing of information, giving workers a reasonable opportunity to express views and taking those views into account before making decisions on health and safety matters.

**Section 47** A person conducting a business or undertaking must consult, so far as is reasonably practicable, with workers who carry out work for the business or undertaking and who are (or

are likely to be) directly affected by a work health and safety matter.

**Section 48** If the workers are represented by a health and safety representative, the consultation must involve that representative.

Consultation with workers and their health and safety representatives is required at every step of the risk management process. By drawing on the experience, knowledge and ideas of your workers you are more likely to identify all hazards and choose effective risk controls.

### ***Consulting, cooperating and coordinating activities with other duty holders***

**Section 46** A person conducting a business or undertaking must, so far as is reasonably practicable, consult, cooperate and coordinate activities with all other persons who have a work health or safety duty in relation to the same matter.

Sometimes you may have responsibility for a health and safety matter along with other business operators who are involved in the same activities or who share the same workplace. In these situations, you should exchange information to find out who is doing what and work together in a cooperative and coordinated way so that all risks are eliminated or minimised so far as is reasonably practicable.

For example, if you engage an electrical contractor to carry out electrical work at your workplace you should consult with the contractor on how (in general) the work is to be carried out and in particular how risks to their health and safety and that of others at the workplace are to be managed while the work is carried out. You should also cooperate with the electrical contractor (e.g. instructing on and ensuring compliance with 'no go' zones') to ensure electrical safety of everyone at the workplace.

Further guidance on consultation is available in the *Code of Practice: Work Health and Safety Consultation, Cooperation and Coordination*.

### ***Information, training, instruction and supervision***

**Section 19** A person conducting a business or undertaking must ensure, so far as is reasonably practicable, the provision of any information, training, instruction or supervision that is necessary to protect all persons from risks to their health and safety arising from work carried out.

**Regulation 39** You must ensure that information, training and instruction provided to a worker is suitable and adequate having regard to:

- the nature of the work carried out by the worker
- the nature of the risks associated with the work at the time the information, training or instruction is provided
- the control measures implemented.

You must ensure, so far as is reasonably practicable, that the information, training and instruction is provided in a way that is readily understandable by any person to whom it is provided.

Formal or on-the-job training may be appropriate depending on the circumstances. Examples of training are:

- induction training—to ensure new starters or workers new to a job are trained on safe systems of work and other relevant health and safety matters
- supervisor and management training—to ensure that safety issues are appropriately managed at the workplace
- work-specific training—to ensure that workers carrying out particular work are trained on any electrical and other risks specific to the work, as appropriate
- ongoing or refresher training—to ensure that any training on work health and safety matters is repeated as appropriate on a periodic basis
- emergency procedure training—to ensure workers know what to do in the event of an emergency, for example procedures to follow if a person receives an electric shock
- first aid training—to ensure appropriate procedures are followed for administering first aid, for example proper treatment for electric shock
- electrical rescue and resuscitation training for safety observers.

Special needs of workers should be taken into account in deciding the structure, content and delivery of training, including literacy levels, work experience and specific skills required to carry out the work.

**PART A:  
GENERAL ELECTRICAL  
SAFETY AT THE  
WORKPLACE**

## **2. THE RISK MANAGEMENT PROCESS**

### **2.1 IDENTIFY THE HAZARDS**

Identifying hazards involves finding all of the tasks, situations and sequences of events that could potentially cause harm.

Hazards arising from electrical equipment or installations may arise from:

- the design, construction, installation, maintenance and testing of electrical equipment or electrical installations
- design change or modification
- inadequate or inactive electrical protection
- where and how electrical equipment is used. Electrical equipment may be subject to operating conditions that are likely to result in damage to the equipment or a reduction in its expected life span. For example, equipment may be at greater risk of damage if used outdoors or in a factory or workshop environment
- electrical equipment being used in an area in which the atmosphere presents a risk to health and safety from fire or explosion, for example confined spaces
- type of electrical equipment. For example, 'plug in' electrical equipment that may be moved around from site to site, including extension leads, are particularly liable to damage
- the age of electrical equipment and electrical installations
- work carried out on or near electrical equipment or electrical installations, including electric overhead lines or underground electric services, for example work carried out in a confined space connected to plant or services.

Exposure to high electromagnetic fields may also present a potential hazard for workers with some medical conditions, for example pace makers. You must inform workers and other persons at the workplace of any potential electromagnetic hazards at the workplace that may affect a medical condition. You must also manage risks to health and safety arising out of electromagnetic hazards, including eliminating the risk so far as is reasonably practicable. If that is not reasonably practicable you must minimise the risk so far as is reasonably practicable.

Potential electrical hazards may be identified in a number of different ways including:

- talking to workers and observing where and how electrical equipment is used

- regularly inspecting and testing electrical equipment and electrical installations as appropriate
- reading product labels and manufacturers' instruction manuals
- talking to manufacturers, suppliers, industry associations, and health and safety specialists
- reviewing incident reports.

## **2.2 ASSESS THE RISKS**

Risk assessment involves considering what could happen if someone is exposed to a hazard (consequence) and the likelihood of it happening.

For work on energised electrical equipment, the WHS Regulations require that a risk assessment be prepared in writing by a competent person; for more information see Part B of this Code.

A risk assessment can help determine:

- the severity of an electrical risk
- whether existing control measures are effective
- what action you should take to control an electrical risk
- how urgently the action needs to be taken.

To assess the risk associated with electrical hazards consider:

- What is the potential impact of the hazard?
  - How severe could the electrical hazard be? For example, direct contact causing electrocution, fire or explosion causing serious burns or death.
  - How many people are exposed to the hazard?
- How likely is the hazard to cause harm?
  - Could it happen at any time or would it be a rare event?
  - How frequently are workers exposed to the hazard?

Other factors that may affect consequence and likelihood include:

- the conditions under which the electrical equipment is used, for example wet conditions outdoors or confined spaces
- work practices and procedures, for example isolation, to carry out maintenance
- the capability, skill and experience of relevant workers.

## **2.3 CONTROL THE RISKS**

Once hazards have been identified and the risks assessed, appropriate control measures must be put in place.

The ways of controlling risks are ranked from the highest level of protection and reliability to the lowest. This ranking is known as the hierarchy of risk control. You must work through this hierarchy to choose the control that most effectively eliminates or minimises the risk in the circumstances, so far as is reasonably practicable. This may involve a single control measure or a combination of two or more different controls.

### ***Elimination***

The most effective control measure is to remove the hazard or hazardous work practice. By designing-in or designing-out certain features, hazards may be eliminated.

### ***Substitution***

Replacing a hazardous process or material with one that is less hazardous will reduce the hazard, and hence the risk. For example, it may be reasonably practicable to use extra-low voltage electrical equipment such as a battery-operated tool rather than a tool that is plugged into mains electricity.

### ***Isolation***

Preventing workers from coming into contact with the source of an electrical hazard will reduce the relevant risks.

### ***Engineering controls***

Use engineering control measures to minimise the risk, for example installing residual current devices to reduce the risk of receiving a fatal electric shock.

### ***Administrative controls***

Administrative controls involve the use of safe work practices to control the risk, for example establishing exclusion zones, use of permits and warning signs.

### ***Personal protective equipment (PPE)***

PPE includes protective eyewear, insulated gloves, hard hats, aprons and breathing protection. Most forms of PPE are not relevant to minimising electrical risks in workplaces, except in relation to energised electrical work.

Administrative controls and PPE do nothing to change the hazard itself. They rely on people behaving as expected and require a high level of supervision. Exclusive reliance on administrative controls and PPE must only occur where other measures are not

reasonably practicable or as an interim control while the preferred control measure is being implemented.

You should check that your chosen control measure does not introduce new hazards.

## 2.4 REVIEW THE CONTROL MEASURES

The controls that are put in place to protect health and safety must be reviewed regularly to make sure they work effectively.

**Regulation 38** A person conducting a business or undertaking must review and as necessary revise a control measure in the following circumstances:

- when the control measure does not control the risk it was implemented to control so far as is reasonably practicable
- before a change at the workplace that is likely to give rise to a new or different risk to health or safety that the measure may not effectively control
- if a new relevant hazard or risk is identified
- if the results of consultation indicate that a review is necessary
- if a health and safety representative requests a review.

The following questions will help you evaluate how well you are currently managing electrical risks in your workplace:

- Do you talk to your workers about electrical safety? Do any relevant new work methods or equipment have the potential to make work safer in your workplace?
- Are procedures for identifying electrical hazards in the workplace effective?
- Are electrical safety procedures followed? Do you encourage your workers to report electrical hazards?
- Do you regularly inspect and maintain your electrical equipment to identify safety problems?
- Do you fix or rectify identified electrical hazards in a timely manner?



### 3. SPECIFIC HAZARDS AND RISK CONTROL

There are a number of things you should do to manage the risks to health and safety associated with electrical risks at the workplace including:

- Ensure power circuits are protected by the appropriate rated fuse or circuit breaker to prevent overloading.
- If the circuit keeps overloading, don't increase the fuse rating as this creates a fire risk due to overheating; instead ensure the circuit is not re-energised until the reason for the operation has been determined by a competent person.
- Arrange electrical leads so they will not be damaged. So far as is reasonably practicable, avoid running leads across the floor or ground, through doorways and over sharp edges, and use lead stands or insulated cable hangers to keep leads off the ground. In many heavy industries, cable protection ramps are used to protect cables.
- Don't use leads and tools in damp or wet conditions unless they are specially designed for those conditions.
- Ensure circuits where portable electrical equipment can be connected are protected by appropriate RCDs (as required by the WHS Regulations) that are properly tested and maintained.
- If RCDs, circuit breakers or other over current protective devices including fuses are triggered into operation, ensure circuits are not re-energised until the reason for the operation has been determined by a competent person.
- Ensure RCDs are effective by regular testing.

#### 3.1 UNSAFE ELECTRICAL EQUIPMENT AND ELECTRICAL INSTALLATIONS AT THE WORKPLACE

**Regulation 149** A person conducting a business or undertaking that has management or control of electrical equipment must ensure that any unsafe electrical equipment at the workplace is disconnected (or isolated) from its electricity supply and, once disconnected, is not reconnected until it is repaired or tested and found to be safe or is replaced or permanently removed from use.

Electrical equipment is unsafe if there are reasonable grounds for believing it to be unsafe.

You should implement a safe system of work to deal with potentially unsafe electrical equipment at the workplace. This could include:

- requiring workers (if competent to do so) to undertake a check of the physical condition of the electrical equipment, including the lead and plug connections, prior to commencing use
- taking the electrical equipment out of service if in doubt as to safety, including at any time during use
- putting reporting arrangements in place to ensure, so far as is reasonably practicable, that supervisors or line managers are advised if a worker takes electrical equipment out of service for safety reasons.

Unsafe electrical equipment must be disconnected or isolated from its electricity supply. It must not be reconnected unless it is repaired by a competent person or tests by a competent person have confirmed it is safe to use. Alternatively, it could be replaced or permanently removed from use.

Unsafe electrical equipment should be labelled indicating it is unsafe and must not be used. This is to prevent inadvertent use before the electrical equipment can be tested, repaired or replaced.

### **3.2 INSPECTING AND TESTING ELECTRICAL EQUIPMENT**

Inspecting and testing electrical equipment will assist in determining whether it is electrically safe.

Regular visual inspection can identify obvious damage, wear or other conditions that might make electrical equipment unsafe. Many electrical defects are detectable by visual inspection.

Regular testing can detect electrical faults and deterioration that cannot be detected by visual inspection.

The nature and frequency of inspection and testing will vary depending on the nature of the workplace and the risks associated with the electrical equipment.

Lower-risk workplaces include those workplaces that are dry, clean, well-organised and free of conditions that are likely to result in damage to electrical equipment, for example an office, retail shop, telecommunications centre, classroom, etc. Electrical equipment commonly used in these types of lower-risk workplaces includes computers, photocopiers, stationery or fixed electrical equipment. A key source of information on dealing with the inspection and testing of electrical equipment is the manufacturer's recommendations.

In this section a reference to 'inspection' or 'testing' excludes repair of electrical equipment.

### ***Inspecting and testing electrical equipment—other than equipment used in specified higher-risk operating environments***

Not all electrical items need to be inspected and tested under Regulation 150—for legal requirements see Sections 0 and 0 of this Code, which deal with inspection and testing requirements for electrical equipment used in specified higher-risk operating environments. Electrical equipment used in lower-risk operating environments does not require inspection and testing or ‘tagging’.

Guidance on inspecting and testing electrical equipment in lower-risk operating environments is included in *AS/NZS 3760:2010 In-service safety inspection and testing of electrical equipment* (if covered by that Standard) and may also be included in the manufacturer’s recommendations.

AS/NZS 3760:2010 sets out indicative inspection and testing intervals for certain electrical equipment, including RCDs, used in a variety of different operating environments.

In addition to regular testing, electrical equipment should also be tested:

- after a repair or servicing that could affect the electrical safety of the equipment (i.e. undertaken by the person carrying out the repair or servicing before return to service)
- before its first use if bought second-hand.

Inspection and testing of electrical equipment may involve, in part:

- looking for obvious damage, defects or modifications to the electrical equipment, including accessories, connectors, plugs or cord extension sockets
- looking for discolouration that may indicate exposure to excessive heat, chemicals or moisture
- checking the integrity of protective earth and insulation resistance
- checking that flexible cords are effectively anchored to equipment, plugs, connectors and cord extension sockets
- looking for damage to flexible cords
- checking that operating controls are in good working order i.e. they are secure, aligned and appropriately identified
- checking that covers, guards, etc. are secured and working in the manner intended by the manufacturer or supplier

- checking that ventilation inlets and exhausts are unobstructed
- checking that the current rating of the plug matches the current rating of the associated electrical equipment.

Note that AS/NZS 3760:2010 specifically excludes medical devices and electrical devices in patient care areas. For more information see AS/3551:2004 *Technical management programmes for medical devices* or AS/NZS 3003:2011 *Electrical Installations – patient areas*.

#### *New equipment*

Brand-new electrical equipment that has never been put into use (i.e. other than second-hand equipment) does not have to be tested before first use.

Brand-new electrical equipment, however, should still be visually inspected to ensure that no damage occurred during transport, delivery, installation or commissioning.

If the electrical equipment is required to be tested regularly for safety, take the necessary steps to ensure that it does not miss its first required test.

The date the electrical equipment was placed into service should be recorded (e.g. on the record of installation or elsewhere). The electrical equipment may also be fitted with a tag stating:

- that the equipment is 'new to service'
- the date of entry into service
- the date when the first electrical safety test is due
- that the equipment has not been tested.

Fitting a 'new to service' tag is an administrative task that can be carried out by an appropriately trained in-house person.

Alternatively, a different system may be put into place to ensure the electrical equipment is properly inspected and tested as required (e.g. the new electrical equipment can be included in the next round of electrical testing carried out at the workplace).

#### ***Inspecting and testing equipment—regulatory requirements for specified higher-risk operating environments other than construction or demolition sites***

**Regulation 150** A person conducting a business or undertaking with management or control of electrical equipment must ensure that the electrical equipment is regularly inspected and tested by a competent person if the electrical equipment is:

- supplied with electricity through an electrical socket outlet ('plug in' equipment), and

- used in an environment in which its normal use exposes the equipment to operating conditions that are likely to result in damage to the equipment or a reduction in its expected life span.

This includes conditions that involve exposing the electrical equipment to moisture, heat, vibration, mechanical damage, corrosive chemicals or dust.

You must ensure, so far as is reasonably practicable, that electrical equipment is not used if the equipment is required to be tested under these requirements but has not been tested. Possible actions may include the storing of equipment in locked areas to prevent use or the use of 'lock out' labels and tags.

Inspection and testing requirements apply in relation to:

- certain higher-risk workplaces in which electrical equipment is exposed to operating conditions that are likely to result in damage to the equipment or a reduction in its expected life span
- construction and demolition sites (see Section 0 of this Code).

These operating environments have the potential to seriously affect the safe operation of electrical equipment. This includes conditions that involve exposing the electrical equipment to moisture, heat, vibration, mechanical damage, corrosive chemicals and dust. Examples include wet or dusty areas, outdoors, workplaces that use corrosive substances, commercial kitchens and manufacturing environments.

A risk assessment can help determine whether electrical equipment is being used in any of these operating environments at a particular workplace.

For guidance on appropriate inspection and testing intervals, seek the advice of a competent person (see below). Further guidance may be included in *AS/NZS 3760:2010 In-service safety inspection and testing of electrical equipment* and the manufacturer's recommendations.

As a general rule electrical equipment used in the specified higher-risk operating environments should be tested at least once every 12 months. More frequent testing may be required, for example in relation to:

- electrical equipment used in manufacturing and workshop environments (e.g. at least once every 6 months)
- commercial cleaning equipment (e.g. at least once every 6 months)

- hire equipment (e.g. at least once every 3 months).

#### *Hire equipment*

Persons conducting a business or undertaking hiring out electrical equipment must ensure the equipment is inspected at the commencement of each hire and tested every three months.

The person conducting a business or undertaking using the electrical equipment hired out must ensure that, for the period of the hire, the equipment meets all applicable inspection and testing requirements under the WHS Regulations and this Code.

#### ***Competency requirements for those carrying out inspection and testing of electrical equipment***

Inspection and testing of electrical equipment must be carried out by a person who has acquired, through training, qualification or experience, the knowledge and skills to carry out the task (i.e. be a 'competent person'). Inspection and testing of electrical equipment must be carried out by a competent person who has the relevant knowledge, skills and test instruments to carry out the relevant inspection and testing. The person carrying out any testing of electrical equipment should also be competent to interpret the test results of any equipment they use. For example, a person carrying out testing under AS/NZS 3760:2010 must be:

- a licensed or registered electrician (whichever applies), or
- in some jurisdictions, a licensed electrical inspector, or
- a person who has successfully completed a structured training course and been deemed competent in the use of a pass-fail type portable appliance tester and the visual inspection of electrical equipment.

The training should be designed to ensure, so far as is reasonably practicable, that on completion successful participants:

- can use the relevant test equipment safely and effectively
- understand electrical risks and appreciate the role that inspection and testing plays in ensuring electrical safety
- understand AS/NZS 3760:2010 and AS/NZS 3012:2010 (if testing equipment for construction or demolition sites)
- understand the legal requirements relevant to the work.

Some kinds of electrical testing must only be carried out by a licensed electrician or electrical inspector under local electrical safety laws. For example, testing requiring the dismantling of electrical equipment should only be carried out by a licensed electrician.

Additional or different competencies may be required for more complex kinds of testing outside the scope of AS/NZS 3760:2010.

If in doubt, advice should be obtained from a person qualified and experienced in electrical equipment testing, for example an electrician, electrical contractor, electrical inspector, specialist testing provider or relevant regulator.

### ***Recording results of testing***

**Regulation 150** A record of testing must be kept until the electrical equipment is next tested, permanently removed from the workplace or disposed of. A record of testing must specify the following:

- the name of the person who carried out the testing
- the date of the testing
- the outcome of the testing, and
- the date on which the next testing must be carried out.

The record may be in the form of a tag attached to the electrical equipment tested.

#### *Log book or other similar form of record*

The record of testing may take the form of a log book, database, register or a similar kind of record, or a tag. Log books and similar records have the advantage of:

- ensuring there is a permanent record of inspection and testing (for example, as a backup if tags are damaged or removed)
- facilitating internal audit
- allowing more detailed information to be recorded.

#### *Tag*

If the record of testing is a tag, it should be durable, water resistant, non-metallic, self-adhesive or well-secured, incapable of re-use and have a bright, distinctive surface.

The tag may also be colour-coded to identify the month in which the testing was carried out.

A tag may not include all of the required information. In that case, the rest of the required information must be recorded elsewhere and kept for the relevant period of time.

If a tag is not used you should ensure that tested electrical equipment is marked or labelled so that records of testing can clearly identify the relevant equipment.

### 3.3 INSPECTING AND TESTING EQUIPMENT – CONSTRUCTION AND DEMOLITION SITES

**Regulation 163** A person conducting a business or undertaking that includes the carrying out of construction work must comply with AS/NZS 3012:2010 *Electrical installations – Construction and demolition sites*.

AS/NZS 3012:2010 applies as if any term that is defined in that Standard and that is also defined in the WHS Act or Regulations has the same meaning as it has in the WHS Act or Regulations.

If there is any inconsistency between the Standard and Part 4.7 of the WHS Regulations then it is sufficient that the person complies with AS/NZS 3012:2010.

### 3.4 RESIDUAL CURRENT DEVICES (RCDS)

The risk of electric shock often results from people making contact with unprotected energised parts of electrical equipment and earth. Contact with energised parts may occur by touching:

- bare conductors
- internal parts of electrical equipment
- external parts of electrical equipment that have become energised because of an internal fault
- metallic or other conductive equipment that has inadvertently become live.

Contact with earth occurs through normal body contact with the ground or earthed metal parts.

Serious injuries and fatalities may be prevented by the use of properly installed and maintained residual current devices RCDs, commonly referred to as 'safety switches'. An RCD is an electrical safety device designed to immediately switch off the supply of electricity when electricity 'leaking' to earth is detected at harmful levels. RCDs offer high levels of personal protection from electric shock.

RCDs work by continuously comparing the current flow in both the active (supply) and neutral (return) conductors of an electrical circuit. If the current flow becomes sufficiently unbalanced, some of the current in the active conductor is not returning through the neutral conductor and is leaking to earth. RCDs are designed to quickly disconnect the electricity supply when they sense harmful leakage, typically 30 milliamps or less. This ensures an electrical leak is detected and the electricity supply is disconnected before it can cause serious injury or damage.



While RCDs significantly reduce the risk of electric shock they do not provide protection in all circumstances. For example, an RCD will not trigger off electricity supply if a person contacts both active and neutral conductors while handling faulty plugs or electrical equipment and electricity flows through the person's body, unless there is also a current flow to earth.

***When RCDs must be provided for use in workplaces***

**Regulation 164** A person conducting a business or undertaking must ensure, so far as is reasonably practicable, that any electrical risk associated with the supply of electricity to 'plug in' electrical equipment is minimised by the use of an appropriate RCD in certain higher-risk workplaces.

The following requirement only applies if it is reasonably practicable to provide an RCD in the higher risk workplaces:

If electricity is supplied to the equipment requiring an RCD through a socket outlet not exceeding 20 amps the RCD must have a tripping current that does not exceed 30 milliamps.

This does not apply if the supply of electricity to the electrical equipment:

- does not exceed 50 volts alternating current, or
- is direct current, or
- is provided through an isolating transformer that provides at least an equivalent level of protection, or
- is provided from a non-earthed socket outlet supplied by an isolated winding portable generator that provides at least an equivalent level of protection.

***Construction and demolition sites***

You must comply with AS/NZS 3012:2010 in relation to RCD requirements for construction and demolition sites.

RCD requirements only apply in relation to workplaces where electrical equipment supplied with electricity through a socket outlet (plug-in electrical equipment) is used or may be used in certain higher-risk workplaces. These are workplaces with operating conditions where:

- the normal use of electrical equipment exposes the equipment to operating conditions that are likely to result in damage to the equipment or a reduction in its expected life span, including conditions that involve exposure to moisture, heat, vibration, mechanical damage, corrosive chemicals or dust

- electrical equipment is moved between different locations in circumstances where damage to the equipment or to a flexible electricity supply cord is reasonably likely
- electrical equipment is frequently moved during its normal use
- electrical equipment forms part of, or is used in connection with, an amusement device.

Common examples of electrical equipment requiring an RCD include:

- hand-held electrical equipment, for example drills, saws, hair dryers, curling wands and electric knives
- electrical equipment that is moved while in operation, including jackhammers, electric lawn mowers, floor polishers and extension cords
- electrical equipment that is moved between jobs in ways that could result in damage to the equipment, for example electric welders, electric cement mixers, portable bench saws and extension cords.

Additional RCD requirements may be included in AS/NZS 3000:2007, local building and electrical safety laws.

#### ***Other legal requirements***



Additional RCD requirements may be included in local building and electrical safety laws.

#### ***Non-portable (or 'fixed') and portable RCDs***

Non-portable (or 'fixed') RCDs are RCDs that are installed at either the switchboard (see Figure 1) or a fixed socket outlet (see Figure 2).

Non-portable RCDs installed at the main switchboard protect the wiring connected to the RCD and electrical equipment plugged into the protected circuit.

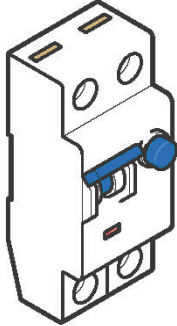
Non-portable RCDs installed at a fixed socket outlet provide protection to electrical equipment plugged into the outlet.

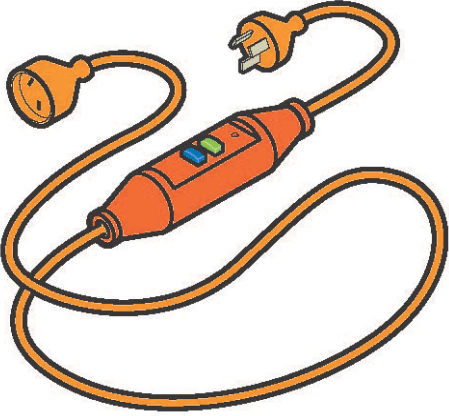
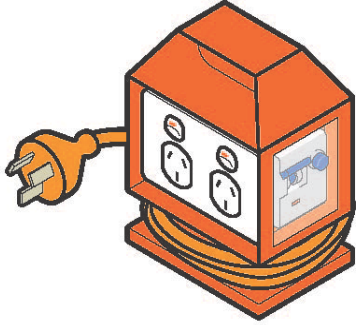
	
<p><b>Figure 1:</b> Switchboard RCD unit</p>	<p><b>Figure 2:</b> Fixed socket outlet RCD unit</p>
	
<p><b>Figure 3:</b> Portable RCD fitted directly to power cable</p>	<p><b>Figure 4:</b> Portable RCD protected power board</p>

Portable RCDs are generally plugged into a socket outlet and, depending on design, may protect one or more items of electrical equipment.

**Classes of RCDs**

RCDs are classified in AS/NZS 3190:2011 Approval and test specification – Residual current devices (current-operated earth-leakage devices). The two relevant types are:

Type	Description	General Guidance – Use
Type I	Type I RCDs have a residual current rating not exceeding 10 milliamps and a tripping time within 30 milliseconds.	Type I RCDs are the most sensitive and are required for electrical equipment that is directly connected to people, for example patients in hospitals or dental practices.
Type II	Type II RCDs have a residual current rating greater than 10 milliamps but not exceeding 30 milliamps and a tripping time within 300	Type II RCDs are most suitable for personal protection against injury including electric shock.

Type	Description	General Guidance – Use
	milliseconds.	

### ***Requirement for ‘appropriate’ RCDs***

The WHS Regulations require ‘appropriate’ RCDs to be selected and used in the specified higher-risk operating conditions. If an RCD is required, the RCD must have a tripping current that does not exceed 30 milliamps if electricity is supplied to the equipment through a socket outlet not exceeding 20 amps.

The WHS Regulations do not prescribe whether RCDs must be non-portable or portable. The most ‘appropriate’ RCD will depend on the workplace environment.

To assist with proper selection, further information about the advantages and disadvantages of different kinds of non-portable and portable RCDs is described in Appendix B.

You may need to seek technical advice from a competent person about the kinds of RCDs that are appropriate for your workplace.

However, for construction and demolition sites you must comply with AS/NZS 3012:2010.

Additional requirements for the installation of non-portable RCDs may also apply under local building and electrical safety laws as set out in AS/NZS 3000:2007 *Electrical installations* (known as the Australian/New Zealand Wiring Rules).

### ***Inspecting and testing RCDs***

**Regulation 165** A person with management or control of a workplace must take all reasonable steps to ensure that residual current devices used at the workplace are tested regularly by a competent person to ensure the devices are working effectively.

A record of testing (other than daily testing) must be kept until the device is next tested or disposed of.

AS/NZS 3012:2010 applies in relation to construction and demolition sites.

Persons with management or control of a workplace must take all reasonable steps to ensure that RCDs used at the workplace are tested regularly by a competent person. This requirement covers RCDs used in all operating environments including non-portable (or ‘fixed’) RCDs.

If an RCD is tested and found to be faulty it must be taken out of service and replaced as soon as possible.

Requirements for inspecting and testing electrical equipment used in certain higher-risk workplaces which could, for example include portable RCDs, are explained in Section 0 of this Code.

For guidance on approval and test specifications, see AS/NZS 3190: *Approval and test specification – Residual current devices*.

***Testing new portable RCDs***

A new portable RCD unit should be tested by pressing the 'trip test' button to ensure the RCD is effective.

---

# **PART B: ELECTRICAL WORK**

## 4. MANAGING THE RISKS OF ELECTRICAL WORK

The WHS Regulations do not modify, supplement or otherwise change licensing or registration requirements (whichever applies) under electrical licensing laws.

**Regulation 146** You must take all reasonable steps to ensure that electrical work that is required to be undertaken by a licensed or registered electrical worker is undertaken by a worker that meets the relevant licensing or registration requirements.

### 4.1 WHAT IS ELECTRICAL WORK?

**Electrical work** means:

- connecting electricity supply wiring to electrical equipment or disconnecting electricity supply wiring from electrical equipment
- installing, removing, adding, testing, replacing, repairing, altering or maintaining electrical equipment or an electrical installation.

Electrical work does not include:

- work that involves connecting electrical equipment to an electricity supply by means of a flexible cord plug and socket outlet
- work on a non-electrical component of electrical equipment if the person carrying out the work is not exposed to an electrical risk
- replacing electrical equipment or a component of electrical equipment if that task can be safely performed by a person who does not have expertise in carrying out electrical work (e.g. replacing domestic fuses or light bulbs)
- assembling, making, modifying or repairing electrical equipment as part of a manufacturing process
- building or repairing ducts, conduits or troughs where electrical wiring is or will be installed if:
  - the ducts, conduits or troughs are not intended to be earthed
  - the wiring is not energised, and
  - the work is supervised by a licensed or registered electrical worker

- locating or mounting electrical equipment, or fixing electrical equipment in place, if this task is not performed in relation to the connection of electrical equipment to an electricity supply
- assisting a licensed electrician to carry out electrical work if:
  - the assistant is directly supervised by the licensed electrician, and
  - the assistance does not involve physical contact with any energised electrical equipment
- carrying out electrical work, other than work on energised electrical equipment, in order to meet eligibility requirements in relation to becoming a licensed electrician.

Electrical work does not include work on electrical equipment that is operated by electricity at extra-low voltage except:

- electrical equipment that is part of an electrical installation that is located in an area in which the atmosphere presents a risk to health and safety from fire or explosion
- in relation to electrical equipment that is part of an active impressed current cathodic protection system within the meaning of AS 2832.1:2004.

#### **4.2 IDENTIFY THE HAZARDS**

See Section 0 of this Code.

#### **4.3 ASSESS THE RISKS**

A risk assessment involves considering what could happen if someone is exposed to a hazard and the likelihood of it happening. Risks associated with electrical work may arise from:

- the properties of electricity. Electricity is particularly hazardous because electrical currents are not visible and do not have any smell or sound
- how and where the electrical work is carried out. Electrical work may be carried out in difficult conditions, including in wet weather conditions, confined spaces and in atmospheres that present a risk to health and safety from fire or explosion
- the competence of the persons carrying out the electrical work.

If energised or 'live' electrical work is proposed to be carried out, a risk assessment must be undertaken before the work starts and it must be carried out by a competent person and recorded.



For more information about energised electrical work, see Section 7 of this Code.

The following risk factors associated with carrying out electrical work should be considered:

- sources of electrical risks, including energy levels at the workplace
- the nature of the electrical work to be carried out
- potential or actual high fault current levels (i.e. risks associated with arc flash)
- availability of isolation points
- work practices
- the type of plant, machinery and equipment to be used
- availability of suitable test instruments
- availability of properly rated PPE
- the workplace and working environment, for example:
  - wet weather conditions
  - in and around trenches, pits and underground ducts
  - ladders, scaffolds, portable pole platforms, elevating work platforms, poles and towers
  - confined spaces
  - ability to safely rescue persons
- the competence of people carrying out the work, noting that licensing requirements may apply for the electrical work under local electrical safety laws.

Also consider individual workers' needs, for example:

- Is the worker experienced in, and have they been properly trained for, the working conditions?
- Is the worker physically fit for the proposed work, for example are they able to climb to heights to work on an overhead conductor or are they mentally alert and not fatigued?
- Does the worker have a visual or hearing impairment, for example do they have a visual colour deficiency or hearing loss?
- Does the worker take any medication that may increase their vulnerability to work in electrical environments?
- Is the worker working excessively long hours?
- Does the worker suffer from claustrophobia?

Appendix C may be used to assist with identifying hazards and assessing risks in carrying out electrical work.

#### **4.4 CONTROL THE RISKS**

Once hazards have been identified and the risks assessed, appropriate control measures must be put in place. Electrical safety generally depends on appropriate training, work planning, and correct testing procedures and techniques.

The ways of controlling risks are ranked from the highest level of protection and reliability to the lowest. This ranking is known as the hierarchy of risk control. You must work through this hierarchy to choose the control that most effectively eliminates or minimises the risk in the circumstances, so far as is reasonably practicable. This may involve a single control measure or a combination of two or more different controls.

##### ***Elimination***

The most effect control measure is to remove the hazard or hazardous work practice. For example, working de-energised rather than energised eliminates significant electrical risks. That is why the WHS Regulations prohibit energised electrical work subject to certain exceptions.

##### ***Substitution***

Replacing a hazardous process or material with one that is less hazardous will reduce the hazard, and hence the risk. For example, it may not be reasonably practicable to eliminate energised electrical work altogether; however, even if it is necessary (for one of the legally permissible reasons) to work on an energised electrical part, it may be possible to de-energise the surrounding parts.

##### ***Isolation***

Preventing workers from coming into contact with the source of the electrical hazard will reduce the relevant risks.

##### ***Engineering controls***

Use engineering control measures to minimise the risk, for example insulation, guarding and installing residual current devices to prevent electric shock.

##### ***Administrative controls***

Administrative controls involve the use of safe work practices to control the risk, for example the provision of suitable and adequate training, establishing exclusion zones, use of permits and warning signs.

##### ***Personal protective equipment (PPE)***

PPE includes protective eyewear, insulated gloves, hard hats, aprons and breathing protection. The PPE should be rated for the work to be done. If working on energised equipment, the PPE must be able to protect the user from the maximum prospective energy available at the work site.

Administrative controls and PPE do nothing to change the hazard itself. They rely on people behaving as expected and require a high level of supervision. Exclusive reliance on administrative controls and PPE must only occur where other measures are not reasonably practicable or as an interim control while the preferred control measure is being implemented. See regulation 36 of the WHS Regulations.

However, administrative controls such as procurement and personnel policies and procedures are very important in relation to electrical risks, as they will help to ensure that electrical work is carried out by a qualified electrician as required by law.

You should check that your chosen control measure does not introduce new hazards.

#### **4.5 REVIEW THE CONTROL MEASURES**

See Section 0 of this Code.

## 5. RISK CONTROLS – WORKING DE-ENERGISED

Electrical work (whether energised or de-energised) must only be carried out by appropriately licensed or registered electrical workers.

For more information about the applicable electrical licensing or registration laws contact Comcare.

### 5.2 GENERAL PRINCIPLES – VERIFICATION OF DE-ENERGISED ELECTRICAL EQUIPMENT

**Regulation 152-156** A person conducting a business or undertaking must ensure that electrical work is not carried out on electrical equipment while the equipment is energised, subject to the prescribed exceptions discussed in Section 0 of this Code.

These provisions do not apply to work carried out by or on behalf of electricity supply authorities on the electrical equipment, including line-associated equipment, controlled or operated by the authority to generate, transform, transmit or supply electricity. This exemption does not extend to the electricity generation sector.

A person conducting a business or undertaking carrying out electrical work must ensure that, before electrical work is carried out on electrical equipment, the equipment is tested by a competent person to determine whether or not it is energised.

The person conducting a business or undertaking must ensure that:

- each exposed part is treated as energised until it is isolated and determined not to be energised, and
- each high-voltage exposed part is earthed after being de-energised.

A person conducting a business or undertaking must ensure that electrical equipment that has been de-energised to allow for electrical work to be carried out cannot be inadvertently re-energised.

The safe work procedure 'TEST FOR 'DEAD' BEFORE YOU TOUCH' must be applied at all times.

Even if the electricity supply is believed to have been isolated, it must be assumed that all conductors and electrical components are energised until they have been proven de-energised.

Testing for 'dead' must be undertaken as appropriate for the duration of the electrical work. Testing is undertaken prior to touching, taking into account all relevant factors including the

nature of the conductor, nature of the isolation, nature of work, if there has been a change or the area has been left idle (unattended) for a period.

The testing method (including the tester used) must be safe and effective. The electrical worker carrying out the testing must understand testing procedures and be competent in the use of the tester.

Panel voltmeters should not be used as the only method of determining whether an electrical part is de-energised.

If voltage testers are used they should be tested for correct operation immediately before use and again after use to confirm that the instrument is still working. This check should be considered to be part of the 'TEST FOR 'DEAD' BEFORE YOU TOUCH' safe work procedure.

If there are any exposed conductors in the immediate work area they should be separated by design or segregated and protected with insulated barricades, insulated shrouding or insulated material to prevent against inadvertent or direct contact.

For more information about testing instruments see Chapter 9 of this Code.

### **5.3 SAFE WORK METHOD STATEMENTS**

**Regulation 161** A person conducting a business or undertaking must ensure that electrical work on energised electrical equipment is carried out in accordance with a safe work method statement.

Safe work method statements are required in relation to prescribed 'high risk construction work', in addition to energised electrical work. For more information about safe work method statements see Section 7.3 of this Code and for 'high risk construction work' see the *Code of Practice: Construction Work*.

### **5.4 WORK ON CABLES (INCLUDING CUTTING CABLES)**

Where work is to be carried out on a cable, the cable should be de-energised.

Cables must be treated as energised and the procedures for working on energised electrical equipment followed until positive tests can be made that prove the cable is de-energised.

If the cable's connections are exposed the connections and attached live parts should be proved to be de-energised and identified before work starts.

Cutting cables presents particular risks. Both ends of the cable should be checked for isolation prior to cutting. Schematic

diagrams or 'as built' diagrams should be checked carefully to establish secondary or metering circuits in multi-cored cables prior to cutting.

Additional precautions should be taken to ensure insulated or covered cables are de-energised, whether the cables are low voltage, high voltage or control cables.

For example, the action of cutting a multi-core control cable is likely to create a risk if secondary current from a current transformer is present. This risk may not be initially apparent; that is, the cable cutters may not be damaged when the cable is cut. A high voltage may develop across the open-circuited secondary winding causing an electric shock, arcing or a fault at a later stage.

Depending on the situation, alternative precautions may include:

- using a cable spiking or stabbing device that is fit for purpose
- a combination of proving it is de-energised and physically tracing the cable.

## 6. LOW VOLTAGE ISOLATION AND ACCESS

Working de-energised on low voltage electrical equipment or circuits requires the electrical equipment or circuits to be effectively isolated from all relevant sources of electricity supply. This may be done using opening switches, removing fuses or links, opening circuit breakers or removing circuit connections.

The standard steps in low voltage isolation are:

<b>Consultation</b>	<ul style="list-style-type: none"> <li>consulting with the person with management or control of the workplace (e.g. in relation to the timing of the work) and notifying any other affected persons as appropriate</li> </ul>
<b>Isolation</b>	<ul style="list-style-type: none"> <li>identifying the circuit(s) requiring isolation</li> <li>disconnecting active conductors from the relevant source(s), noting there may be multiple sources and stand-by systems/generators/photovoltaic systems as well as auxiliary supplies from other boards</li> <li>if a removable or rack out circuit breaker or combined fuse switch is used it should, if reasonably practicable, be racked out or removed then locked open and danger tagged</li> </ul>
<b>Securing the isolation</b>	<ul style="list-style-type: none"> <li>locking the isolating switch(es) where practicable or removing and tying back relevant conductors to protect the person(s) carrying out the electrical work</li> </ul>
<b>Tagging</b>	<ul style="list-style-type: none"> <li>tagging the switching points where possible to provide general information to people at the workplace</li> </ul>
<b>Testing</b>	<ul style="list-style-type: none"> <li>testing to confirm the relevant circuits have been de-energised and any other relevant conductors in the work area</li> </ul>
<b>Re-testing as necessary</b>	<ul style="list-style-type: none"> <li>for example, if the person carrying out the work temporarily leaves the immediate area, checks and tests must be carried out on their return to ensure that the electrical equipment being worked on is still isolated to safeguard against inadvertent reconnection by another person</li> </ul>

	<ul style="list-style-type: none"> <li>• for example, if a wire changes its status when cut, which can occur because it is lifted from earth.</li> </ul>
--	--

The effectiveness of isolation procedures relies on:

- isolation points being readily available/accessible and being suitable for the type of isolation (switching) being conducted
- the necessary hardware
- having isolation procedures documented and accessible to electrical workers in the workplace
- the provision of instruction, information and training of electrical workers involved with the electrical equipment
- appropriate supervision to ensure safe work procedures, including isolation procedures, are followed.

Safe isolation procedures (including the use of locks and tags discussed below) should be developed in consultation with relevant workers. If the workers are represented by a health and safety representative, the consultation must involve that representative.

## 6.1 SECURING THE ISOLATION

**Regulation 156** A person conducting a business or undertaking must ensure that electrical equipment that has been de-energised to allow electrical work to be carried out on it is not inadvertently re-energised while the work is being carried out.

For work on low voltage electrical equipment or circuits, ensure that the correct point of isolation is identified, an appropriate means of isolation is used and the supply cannot be inadvertently re-energised while the work is carried out.

A fundamental principle is that the point of isolation should be under the control of the person who is carrying out the work on the isolated conductors.

Tagging systems should also be used at the point(s) of isolation where possible for general information.

The isolation should be secured by locking off and tagging the electrical equipment as follows.

### ***Instruction, information, training and supervision***

Appropriate instruction, information, training and supervision must be provided to ensure that electrical equipment that has been de-energised to allow electrical work to be carried out is



not inadvertently re-energised. This includes appropriate instruction, information and training on isolation procedures to everyone who may be affected at the workplace.

### ***Locking off***

Isolation points should be fitted with control mechanisms that prevent the electrical equipment from being inadvertently re-energised. The control mechanism should require a deliberate action to engage or disengage the device. It should be able to withstand conditions that could lead to the isolation failing, for example vibration.

This may include switches with a built-in lock and lock-outs for switches, circuit breakers, fuses and safety lock-out jaws (sometimes called 'hasps').

All circuit breakers, switches and combined fuse switch units should be locked off to secure the isolation where possible. See Figure 5 for examples of locking-off methods incorporating danger tags.

Alternative controls may include an additional component, for example a clip, screw, bolt or pin that can be inserted to prevent a switch from being operated. These types of controls should be used in conjunction with additional control measures, such as danger tags and permit systems.

If more than one person is working on the same de-energised electrical installation, individuals should ensure their own personal lock is applied to the isolation point, otherwise the principles of tagging apply (see below).

No-one should operate an isolator or knowingly use equipment where the isolator has a control mechanism attached.

In situations where isolation points are accessible by other persons at the workplace ensure, so far as is reasonably practicable, that the isolation method or system is not able to be inadvertently or easily compromised.

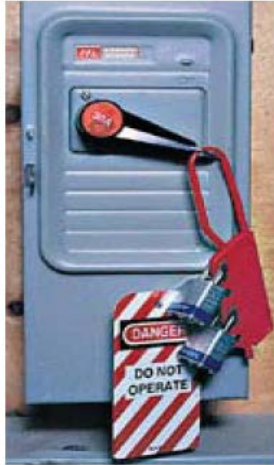

Danger tagged locking off hasp



Danger tagged circuit breaker locking off devices

**Figure 5:** Locking off methods incorporating danger tags

### ***Tagging systems***

#### *Danger tags*

Isolation involves using suitable warning or safety signs as well as locks or other controls to secure the isolation.

Where possible, a tag should be attached to normal locks (as shown in Figure 5) at all points of isolation used to de-energise electrical equipment from its electricity supply.

A tag does not perform the isolation function.

Danger tags are not required when using dedicated personal isolation locks.

Danger tags are used for the duration of the electrical work to warn persons at the workplace that:

- the electrical equipment is isolated or out of service
- the electricity supply must not be switched back on or reconnected
- reconnecting electricity may endanger the life of the electrical worker(s) working on the equipment.

The danger tag should:

- be durable and securely fixed to the isolator
- clearly state the warning, including any warning about specific hazards relating to the isolation (for example, multiple points of supply)

- be dated and signed by the worker or workers involved in carrying out the work or, where appropriate, by the supervisor in charge of the workers
- be attached in a prominent position on each isolation point (i.e. the point or one of many points used to isolate electrical parts) or device
- only be removed by the signatories to the tag. If unavailable and unable to return, measures must be put in place to manage risks associated with removing the lock or tag (e.g. thorough investigation to ensure all workers and others at the workplace are safe).

If the work is incomplete, for example at a change of shift, the last person removes their danger tag or lock and replaces it with a warning tag e.g. out of service or caution.

When work is resumed, the person in charge of the work removes the warning tag (out of service or caution) and each person then applies their danger tag and/or lock.

When work is finally completed, each person removes their danger tag and/or lock.

Where a formal permit system is used, all reasonable steps must be taken to ensure that the designated sign-on and tagging procedures are followed.

#### *Out of service tags*

Out of service or caution tags are used to identify electrical equipment that is not safe to use or fit for purpose. The out of service or caution tag should:

- be durable and securely attached
- clearly state the nature of the defect or reason why the electrical equipment is unsafe
- be attached on a prominent position on each isolation point
- only be removed by a competent person after fixing or rectifying the defect and making the electrical equipment safe, or replacing with a danger tag in preparation to work on the equipment.



**Figure 6:** Example of a danger tag and out of service tag

### ***Testing***

Testing must be carried out to confirm the relevant circuits have been de-energised and the status of any other relevant conductors in the work area.

### ***Bonding conductors***

For guidance on bonding conductors if electrical equipment is isolated at a remote location or there is a risk of induced voltage being present, see AS/NZS 4836.

## **6.2 ALTERING ISOLATION FOR TESTING, FAULT FINDING AND RE-ENERGISING**

It may be necessary to change an isolation point to allow for testing or fault finding on energised parts, for example testing

that may be required before returning electrical equipment to service and commissioning new electrical equipment.

Any testing or fault finding on energised parts must be carried out in accordance with requirements for energised electrical work, which are discussed in Section 0 of this Code.

If electricity supply is restored to part of the circuit then safe procedures for restoring electricity supply must be followed.

### **6.3 RESTORING POWER**

All reasonable steps must be taken to ensure that restoring electricity supply following isolation does not pose risks to health and safety at the workplace. For example:

- appropriately terminating all conductors
- carrying out appropriate testing on any new, altered or repaired electrical equipment, for example tests for insulation resistance, earth continuity, polarity, correct connection and function testing
- removing safeguards, including temporary bonds and short-circuiting devices
- notifying all workers working on the electrical equipment and other affected workers at the workplace that electricity is to be restored
- taking precautions as appropriate to ensure that other electrical equipment is not inadvertently energised
- following procedures for removing any locks (or other control mechanisms), tags, notices and safety signs
- carrying out a visual inspection to ensure that all tools, surplus material and waste has been removed from the workplace.

When electricity is restored tests must be carried out to confirm that polarity is correct, actives are switched and, where applicable, phase sequences are correct before electrical equipment is used. For further information refer to AS/NZS 3017:2007 *Electrical installations – Verification guidelines*.

### **6.4 LEAVING UNFINISHED WORK**

If work is left unfinished, the workplace must be left in a safe state including, for example, by:

- terminating any exposed conductors
- physically securing any exposed conductors or surrounding metal work

- tagging, taping off the electrical equipment and the workplace area
- informing affected persons at the workplace the work is not complete and advising of potential hazards
- taking any necessary precautions to ensure that electrical equipment cannot become inadvertently re-energised
- ensuring that the status of switchboards and electrical equipment are clearly and correctly labelled
- handing over adequate information to workers taking up the unfinished work to allow them to continue the work safely.

## 7. RISK CONTROLS – ENERGISED ELECTRICAL WORK

### 7.1 PROHIBITION ON ENERGISED ELECTRICAL WORK

**Regulation 152 and 157** A person conducting a business or undertaking carrying out electrical work must ensure the work is not carried out on energised electrical equipment unless:

- it is necessary in the interests of health and safety that the electrical work is carried out while the equipment is energised (e.g. it may be necessary for life-saving equipment to remain energised and operating while electrical work is carried out on the equipment), or
- it is necessary that the electrical equipment to be worked on is energised in order for the work to be carried out properly, or
- it is necessary for the purposes of testing to ensure the equipment is de-energised as required by regulation 155, or
- there is no reasonable alternative means of carrying out the work,

These requirements in relation to energised electrical work do not apply to work carried out by or on behalf of electricity supply authorities on the electrical equipment, including line-associated equipment, controlled or operated by the authority to transform, transmit or supply electricity. These authorities may be covered by separate electrical safety requirements.

Energised electrical work is electrical work carried out in circumstances where the part of electrical equipment being worked on is connected to electricity or 'energised'.

Electrical work must not be carried out on electrical equipment while energised only because it is merely more convenient for the electrical equipment to stay energised while the work is being carried out.

Energised electrical work must not be carried out unless the safety risk to those persons directly affected by a supply interruption is higher than the risk to the licensed or registered electrical workers proposed to carry out the energised electrical work. Only in extremely rare circumstances would it be possible to justify that it is not practicable to have a short break in supply. Most electrical installations suffer no harm through unplanned interruptions of this kind to the network supply. In some cases a short break may allow for the insertion (and removal) of insulated barriers.

A Person conducting a business or undertaking requiring electrical work to be carried out may provide operational reasons appearing to justify energised electrical work. Requiring electrical work to be carried out while the equipment is energised when it could be avoided places an onerous responsibility on the business or undertaking commissioning the work to minimise the risks. Should an incident occur as a result of carrying out energised electrical work, the business or undertaking commissioning the work is at risk of being found not to have provided a safe workplace. This could contravene the primary duty of care under the WHS Act.

Energised electrical work is generally prohibited unless one or more of the exceptions under the WHS Regulations applies and the work is carried out in accordance with the WHS Regulations.

## 7.2 PLANNING AND PREPARATION

**Regulation 158** If electrical work is to be carried out on energised electrical equipment a person conducting a business or undertaking must ensure before the work commences that:

- a risk assessment is conducted by a competent person in relation to the proposed work and recorded
- the area where the electrical work is to be carried out is clear of obstructions so as to allow for easy access and exit
- the point at which the electrical equipment can be disconnected or isolated from its electricity supply is:
  - clearly marked or labelled, and
  - cleared of obstructions so as to allow for easy access and exit by the worker who is to carry out the electrical work or any other competent person, and
  - capable of being operated quickly
- the person authorises the electrical work after consulting with the person with management or control of the workplace.

Requirements relating to the point of supply under the third dot point above do not apply if the work is to be carried out on the supply side of the main switch on the main switchboard for the equipment and the point at which the equipment can be disconnected from its electricity supply is not reasonably accessible from the work location.

### ***Risk assessments***

See Section 0 for information on assessing the risks.



In addition to the listed considerations, the assessment should be designed to check compliance with the legislative requirements described above.

For energised electrical work, any significant findings should be recorded, reviewed from time to time and revised if necessary. See Section 0 of this Code for a description of triggers for review.

### ***Consultation between duty holders***

All persons conducting a business or undertaking at a workplace have a duty to manage electrical risks at the workplace while electrical work is being carried out, not just those carrying out the electrical work.

Electrical work will often be carried out at a place that is not under the management or control of the person conducting the business or undertaking carrying out the electrical work. For example, the place where work is carried out may be under the management or control of:

- if the place is a permanent workplace—the person conducting a business or undertaking from that workplace
- if the place is a public place—the relevant local or state authority.

These persons will also have duties in relation to the health and safety of the electrical worker(s) and other persons at the place where the electrical work is being carried out.

All duty holders must, so far as is reasonably practicable, consult, cooperate and coordinate activities with each other to ensure compliance with their work health and safety duties.

In addition to the general duty to consult, the person conducting a business or undertaking carrying out the electrical work must ensure the electrical work is only authorised (among other things) after consulting with the person with management or control of the workplace.

Consultation should ensure that all relevant persons are aware of any scheduled electrical work to be carried out and also any relevant risks to health and safety arising from that work.

Arrangements should also be put in place to ensure, so far as is reasonably practicable, that all persons at the place receive suitable and adequate information and instruction, for example about the need to comply with warning or safety signs and stay out of any no go zones.

### ***Residential premises***

Occupiers of residential premises (as a person at a workplace) must take reasonable care that their acts or omissions do not adversely affect the health or safety of other persons, including that of electrical workers at their premises.

### **7.3 CARRYING OUT ENERGISED ELECTRICAL WORK**

**Regulation 161** A person conducting a business or undertaking must ensure that electrical work carried out on energised electrical equipment is carried out:

- by a competent person who has tools, testing equipment and PPE that are suitable for the work, have been properly tested and are maintained in good working order
- in accordance with a safe work method statement prepared for the work, and
- subject to the exception explained below—with a safety observer present who is competent:
  - to implement the control measures in an emergency
  - to rescue the worker who is carrying out the work if necessary, and
  - has been assessed in the previous 12 months as competent to rescue and resuscitate a person.

A safety observer is not required if the work consists only of testing and the risk assessment shows there is no serious risk associated with the proposed work.

The person must ensure, so far as is reasonably practicable, that the person who carries out the electrical work uses the tools, testing equipment and PPE properly.

Additionally:

- workers carrying out the electrical work must have or be provided with suitable and adequate information, instruction and training in:
  - planning and preparation requirements for the carrying out of energised electrical work
  - safe work procedures, particularly those documented in safe work method statements
  - proper use of the relevant tools, testing equipment and PPE
- first aid facilities must be provided at the workplace and they must be readily accessible

- emergency contact numbers should be made available at the workplace
- fire fighting equipment that is suitable for electrical fires should be accessible
- the person with management or control of the workplace must be consulted before the electrical work is authorised
- energised conductors should be insulated where necessary to prevent inadvertent contact or flashovers
- unauthorised persons should be prevented from entering the work area, for example through the use of barriers and signage.

Many of these requirements require consultation, cooperation and coordination between multiple duty holders at the workplace.

Safe work method statements prepared for energised electrical work must describe consultation arrangements with the person with management or control of the workplace, including any authorisation procedures and position descriptions.

### ***Safe work method statements***

Safe work method statements document a process for identifying and controlling health and safety hazards and risks. They may also incorporate a risk assessment.

Safe work method statements must be developed in consultation with relevant workers. If the workers are represented by a health and safety representative, the consultation must involve that representative.

Safe work method statements must:

- identify the electrical work
- specify the hazards associated with that electrical work and risks associated with those hazards
- describe the measures to be implemented to control the risks
- describe how the risk control measures are to be implemented, monitored and reviewed, and may include the risk assessment prepared for the relevant work.

Safe work method statements must be written in a way that makes them readily understandable by the workers who are to use them.

A copy must be readily accessible to any worker who is to carry out the electrical work covered by the statement.

Safe work method statements must be kept up-to-date. They must, for example, be revised if a decision is made to change relevant safe work procedures at the workplace.

Appendix D to this Code includes a preventative actions checklist that may help you to identify hazards associated with electrical work and develop safe work methods.

If the electrical work falls within the description of 'high risk construction work' then the construction regulations in the WHS Regulations will also apply. For more information see the *Code of Practice: Construction Work*.

### ***Record keeping requirements***

**Regulation 162** A person conducting a business or undertaking carrying out electrical work must keep:

- a copy of the risk assessment until at least 28 days after the work to which it relates is completed, and
- a copy of the safe work method statement until the work to which it relates is completed.

If a 'notifiable incident' under Part 3 of the WHS Act occurs in connection with the work to which the assessment or statement relates, the person must keep the assessment or statement (as the case requires) for at least two years after the incident occurs.

### ***Hazards indirectly caused by electricity—conductive materials***

Persons can be exposed to electrical risks, including risks of electric shock, arcing and explosion, without directly contacting exposed energised parts of electrical equipment. Other conductive materials can provide current paths for the electric shock, fault current or both.

All materials should be regarded as conductive unless proved otherwise. Gases and liquids should be regarded as conductive. Particular care should be taken when exposed energised parts are near earthed situations.

The electric shock path to earth can be via conductive materials, such as concrete, timber with a high moisture content or water. For example, ladders that are damp or dirty may become conductive and create a potential hazard.

When working near exposed energised parts or working energised, the tools and equipment used should be non-conductive or insulated. Examples include:

- torches

- telescopic devices
- rulers and tape measures
- insulated hand tools, for example screwdrivers, pliers, cable cutters, spanners and crimpers
- electrical or hydraulic powered tools.

Metallic personal items including watches and watchbands should not be worn by workers carrying out work near exposed energised parts. Metal objects worn on or close to the body increase the risk of electric shock. Additionally, electrical burns can be more serious because these objects retain heat and provide contact points for current to flow.

Examples of metallic personal items include jewellery, body piercings and metal spectacle frames.

### ***Tools and equipment***

All workers should be competent in the safe use of their tools and equipment (including PPE). For more information about maintaining and inspecting tools and equipment, including testing and fault finding instruments, see Section 0 of this Code.

### ***Work position***

Electrical work should be carried out from a position that minimises the risk of inadvertent contact with exposed energised parts and also the risk of an electric shock path being created. For example, safe work method statements should require, so far as is reasonably practicable, that electrical workers position themselves so that:

- an involuntary action like sneezing would not cause them to touch exposed energised parts
- no electric shock path can be created due to working in an awkward position, for example testing components towards the rear of a washing machine via the front panel
- no electric shock path can be created when carrying out phase sequencing or rotation testing on overhead mains or at an underground pillar.

### ***Safety observers***

A competent safety observer must be present when work is carried out on energised electrical equipment, unless the work consists only of testing and a risk assessment shows that there is no serious risk associated with the proposed work.

The role of the safety observer should be clearly communicated and understood. The safety observer must:

- be competent to implement the control measures in an emergency
- be competent to rescue the worker who is carrying out the work if necessary, and must have been assessed in the previous 12 months as competent to rescue and resuscitate a person.

The safety observer should:

- not carry out any other work or function that compromises their role, for example they should not be required to observe more than one task at a time
- not be situated in the work basket of the elevating work platform from which the electrical work is being carried out
- be able to communicate quickly and effectively with the electrical worker(s) carrying out the work. Specialist equipment may be necessary if there is a barrier to communication
- not have any known temporary or permanent disabilities that would adversely affect their role and performance.

### ***Safety barriers and signs***

Barriers and signs may be designed, erected or installed to:

- protect electrical workers from inadvertently contacting energised exposed parts
- ensure that access to and egress from the work location of live work allows for clear, unobstructed passage
- warn others and direct people away from dangerous work areas.

Different kinds of safety barriers may be required for different purposes. For example:

- to protect electrical workers from inadvertently contacting energised exposed parts—a physical safety barrier should consist of a non-conductive material such as wood or plastic or, alternatively, correctly earthed steel and be strong enough to withstand the impact from falling objects or loose material
- to exclude persons generally from a work area where there is a risk of energised exposed parts—secure housings, enclosures, doors and room may provide appropriate safety barriers.

A risk assessment should be carried out by a competent person to advise on whether a barrier is appropriate to address the

relevant risks and, if so, appropriate design and correct materials.

The barrier must be erected safely. This may require switching off or isolating the electricity supply while the barrier is installed.

A barrier may be temporary or permanent and, if applicable, should clearly designate the safe work area by defining the approach path to the relevant piece of equipment.

### ***Emergency planning***

**Regulation 43** An emergency plan for the workplace must be prepared, maintained and implemented at the workplace.

For this purpose, you must consider all relevant matters, including the following:

- the nature of the work being carried out at the workplace
- the nature of the hazards at the workplace
- the size and location of the workplace
- the number and composition of the workers and other persons at the workplace.

Quick action after an electrical incident that causes injury can save a life or significantly reduce the severity of the injury. Even if an electrical incident does not appear to have caused injury at the time, there may be some delayed effects.

Any person who is involved in an electrical incident involving an electric shock should receive medical attention.

Incidents that expose a worker or any other person to a serious risk from an electric shock must be notified to Comcare and may also be notifiable separately to an electrical safety regulator.

A well-prepared emergency response assists in managing the severity of the injury where an incident has occurred and takes into account the health and safety of those required to respond to the incident. For example, in an exposed energised high voltage situation, the electricity supply should be isolated and proved de-energised before carrying out a rescue.

Special consideration must also be given in relation to other higher-risk workplaces including confined spaces, working at heights (e.g. elevating work platforms), workplaces with hazardous atmospheres which present a risk to health or safety from fire or explosion, and trenches, shafts and tunnels.

## **7.4 LEAVING UNFINISHED WORK**

Refer to Section 0 of this Code.

## **7.5 PARTICULAR ENERGISED ELECTRICAL WORK— TESTING AND FAULT FINDING**

### ***De-energised testing methods should be used before energised testing methods***

Fault finding should first be attempted in a de-energised environment using de-energised testing methods. If unsuccessful, energised testing methods may be used subject to meeting the requirements of the WHS Regulations and this Code for working energised.

### ***Planning and preparation, etc.***

Before commencing any testing or fault finding in an energised environment:

- identify exposed conductive parts that could become energised while using test instruments
- use temporary or fixed barriers to prevent electrical workers from inadvertently contacting exposed conductive parts
- use only appropriate insulated and rated tools, test instruments and test probes
- carry out checks to ensure that the test instruments to be used are appropriate and functioning correctly
- use only appropriately rated PPE
- use a safety observer, if required by the risk assessment conducted for the work
- ensure that only authorised persons may enter the immediate area where the work is to be carried out
- carry out a regular review of the work situation to ensure that no new hazards are created during the process.

When testing or fault finding is completed, circuits and equipment must be restored to a safe condition. For example, disconnected conductors should be reconnected and left in a safe state, covers replaced, and accessories and equipment properly secured.

Procedures involving coordination, such as procedures related to switching circuits or equipment on and off during the fault finding or testing process, must be implemented and maintained at all times.

### ***Safe work procedures—hazardous atmospheres***

See AS/NZS 3000:2007 for guidance on electrical testing and fault finding in hazardous atmospheres that present a risk to health and safety from fire or explosion.



## **8. RISK CONTROLS – WORKING NEAR ENERGISED ELECTRICAL PARTS**

Electrical work on any installation, equipment, machinery, plant or appliance may pose a risk of direct or indirect contact with nearby exposed energised electrical parts (e.g. installing or testing circuits on a switchboard adjacent to exposed live electrical parts).

In some circumstances the risks associated with undertaking electrical work near exposed live parts can be equivalent to those associated with live electrical work. Risks to be considered, but not limited to, are those arising from:

- energised parts
- exposed high temperature parts
- moisture entering the electrical equipment.

Identifying and assessing the risks and developing risk control measures as described in the *Code of Practice: How to Manage Work Health and Safety Risks* will provide further assistance in developing safe work practices.

### **8.1 PLANNING AND PREPARATION**

If there is a safety risk associated with working near energised electrical parts a written risk assessment should then be made to help determine the risk level and decide on appropriate risk control measures. Risks include:

- electric shock if exposed energised parts are touched
- explosion, for example if a metal tool is dropped onto bus bars causing a short circuit
- exposed high-temperature parts causing burns to bare skin
- electrical fires induced, for example, by allowing moisture or dust to enter electrical equipment.

The following factors may be taken into account in assessing risks:

- type of work carried out and tools or equipment used
- proximity of the work to energised parts
- the types of tools and equipment used in the work, for example the conductive properties of tools
- environmental conditions such as confined space, wet surfaces or unfavourable weather
- assessing the need to repair equipment while it remains energised, for example cleaning a low voltage switch room

- work that may impose additional risks, for example welding or grinding that could damage adjacent electrical lines or equipment.

## **8.2 WORKING NEAR ENERGISED ELECTRICAL PARTS**

You must work through the hierarchy of controls to choose the control that most effectively eliminates or minimises the risk of working near energised electrical parts, so far as is reasonably practicable. This may involve a single control measure or a combination of two or more different controls.

Under the WHS Regulations substitution, isolation and engineering controls are ranked at the same level of protection, ahead of administrative controls and then PPE.

### ***Elimination***

The most effective control measure is to remove the hazard or hazardous work practice. This could mean electrically isolating the nearby electrical equipment or installation before starting work. When disconnecting the installation or equipment from supply, a method should be applied to ensure the equipment is not reconnected while the work is carried out. For example, you could place the plug in a lockable enclosure. If equipment is connected to supply by fixed wiring, use other suitable means of isolation as discussed elsewhere in this Code. The isolation process should be clearly documented so that everyone involved knows exactly what to do.

Redesigning equipment or work processes could involve designing and installing equipment that does not have energised parts near the work area.

### ***Substitution***

Replacing a hazardous process or material with one that is less hazardous will reduce the hazard, and hence the risk – for example replacing instead of repairing a faulty part. This could mean shorter downtime and not having to work live, lessening or eliminating the risk of exposure.

### ***Isolation***

You may be able to isolate the risk, for example by erecting a physical barrier to prevent any contact with electrical risk, directly or indirectly. A physical barrier should consist of a non-conductive material such as wood or plastic or, alternatively, correctly earthed metal, and be strong enough to withstand any impact from falling objects or loose materials. Before any barriers are erected, a risk assessment must be carried out by a competent person to ensure the appropriate design and correct materials are used. The barrier must be erected safely. This may

require isolating the electricity supply while the barrier is installed.

### ***Engineering controls***

For example, installing residual current devices to prevent electric shock.

### ***Administrative controls***

Administrative controls involve the use of safe work practices to control the risk, for example the provision of suitable and adequate training, establishing exclusion zones, and use of permits and warning signs.

### ***Personal protective equipment (PPE)***

PPE includes protective eyewear, insulated gloves, hard hats, aprons and breathing protection. The PPE should be rated for the work to be done. If working on or near energised equipment, the PPE must be able to protect the user from the maximum prospective energy available at the work site.

## **8.3 IMPLEMENTING RISK CONTROL MEASURES**

In implementing risk controls, you may develop a safe work method statement that:

- specifies the determined risk controls
- sets out the steps that need to be taken to implement the risk controls
- identifies and allocates the resources necessary to implement the measures (i.e. time and expenses)
- allocates responsibilities and accountabilities (e.g. who does what and when)
- sets a date for reviewing the risk controls.

A safe work method statement must be prepared for construction work that is carried out on or near energised electrical installations or services. Further information about these requirements is available in the *Code of Practice: Construction Work*.

## **8.4 REVIEWING RISK CONTROL MEASURES**

See Section 0 of this Code.

## **9. TOOLS AND EQUIPMENT**

### **9.1 INSPECTION AND TESTING**

Tools, instruments and equipment that are poorly maintained, inappropriately used or not fit for purpose can cause injuries, for example:

- inadequately insulated tools and test instruments
- incorrectly rated instruments.

Unrestrained tools may fall into energised switchboards and compromise the integrity (including safety) of the equipment. The use of lanyards around wrists, tool holders and restraints such as tool pouches and baskets may be used to address these risks.

The tools, instruments and equipment used by electrical workers often have special design characteristics, for example many are insulated. Inadequate maintenance may lead to serious electrical risks, for example insulating medium might conceal a mechanical defect that could cause an open circuit in a testing device.

Insulated tools and equipment must be suitable for the work and be maintained in good working order, including by regular maintenance, inspection and testing. Where any doubt exists that the insulation of tools and equipment might not be adequate they should not be used.

Maintenance and inspection should be carried out according to manufacturer's instructions.

### **9.2 LADDERS, SCAFFOLDS AND SIMILAR EQUIPMENT**

Certain ladders, scaffolds and similar equipment may pose electrical risks including:

- metallic or wire reinforced ladders and scaffolds are conductive and may create an electric shock path, for example:
  - a ladder slipping while work is being carried out on it, causing the worker on the ladder to touch exposed energised parts, for example grabbing a mains box
  - a gust of wind blowing an extension ladder into nearby overhead power lines
  - in switchrooms and switchyards—conductive devices such as aluminium ladders and scaffolds creating electric shock paths and current paths to earth, for example a metal wire reinforced ladder causing a fault to ground if the ladder touches a live 33 kV busbar

- when using ladders, scaffolds and similar equipment, workers are more likely to touch open wiring such as overhead lines
- in cases where lines are carrying large currents, conductive scaffolds may become subject to induction
- portable scaffolds may damage insulation when moved if the scaffold strikes conductors or leads.

Consideration should be given to eliminating the use of metallic, wire reinforced or otherwise conductive ladders; these items should not be used in close proximity to equipment where an electrical hazard may result from their use. These types of ladders should be avoided for any kind of electrical work.

Other effective risk control measures may include:

- identifying if there are exposed energised parts nearby. In this situation, risk control measures such as de-energising, fitting covers, using a safety observer, or a combination of these, should be considered
- employing safe work practices, including:
  - two or more people carrying long devices in switchyards and switchrooms in a position below shoulder height
  - two people handling extension ladders in windy conditions
  - restraining ladders using head ropes or footropes, or both
  - if practicable—using a platform-style step ladder
- if conductive scaffolding is used within high-voltage enclosures or in situations where there is induction, bonding the structure to the earthing system. Depending on the construction of the scaffold, a number of sections may need to be bonded to ensure an equipotential state.

### **9.3 INSULATING BARRIERS AND INSULATING MATS**

Insulating covers and mats used for electrical safety purposes should comply with *AS/NZS 2978:1995 Insulating mats for electrical purposes*.

Insulated barriers should be of suitable material to effectively separate electrical workers from adjacent energised equipment.

Insulated covers and mats should be visually inspected for possible defects before and after each use.

## 9.4 TEST INSTRUMENTS

The tools, testing equipment and PPE for testing and fault finding must be suitable for the work, properly tested and maintained in good working order.

Workers carrying out electrical testing must be appropriately trained and competent in test procedures and in the use of testing instruments and equipment, including:

- being able to use the device safely and in the manner for which it was intended
- being able to determine, by inspection, that the device is safe for use, for example the device is not damaged and is fit for purpose
- understanding the limitations of the equipment, for example when testing to prove an alternating current circuit is de-energised, whether the device indicates the presence of hazardous levels of direct current
- being aware of the electrical safety implications for others when the device is being used, for example whether the device causes the electric potential of the earthing system to rise to a hazardous level
- knowing what to do to ensure electrical safety when an inconclusive or incorrect result is obtained.

### ***Checks carried out on test instruments***

Test instruments that are to be used or connected to electrical equipment should meet the following conditions:

- be suitable for the work in terms of their function, operating range and accuracy
- be in good condition and working order, clean and have no cracked or broken insulation. Particular care must be taken regarding the condition of the insulation on leads, probes and clips of test equipment
- pose no danger of electrocution to workers or damage to the electrical equipment during testing
- have suitably insulated leads and connection probes that enable connection or contact with energised parts to be made with minimal risk to the electrical worker
- provide suitable protection against hazards arising from over-voltages that may arise from or during the testing or measurement process.

AS 61010.1:2003 *Safety Requirements for Electrical Equipment for Measurement, Control and Laboratory Use – General requirements* provides a classification for instruments on the basis of their immunity to over-voltage, which is liable to be experienced in different parts of electrical equipment. Devices should be rated as Category III or IV to enable their use on all parts of the equipment.

Test probes and other equipment should be designed and selected so that they cannot inadvertently short circuit between live conductors or live conductors and earth. The terminals of test equipment should be shrouded and all other test sockets on measuring instruments should be designed so as to prevent inadvertent contact with any live test socket or conductor when equipment is in use. Where appropriate, test leads and testing devices need to be provided with suitable fuse protection. Testing equipment, where used in hazardous flammable areas, should be designed and clearly marked as being suitable for use in these conditions.

Testing equipment used for detecting an energised source should be trialled first to prove that it is functioning correctly immediately before and after the test has taken place. The standard test regime is to test a known source of energy, test the de-energised circuit for zero volts then test the known source again. A faulty indicator will always read zero so must be proved before and after the test.

### ***Proximity voltage testers***

To confirm a positive indication and to establish the circuit voltage, the use of an alternative test instrument that incorporates a visual display should be used before commencing electrical work on the equipment.

Testers for detecting an electric field surrounding an energised conductor may not be suitable for testing cables that are surrounded by a metallic screen, enclosed in a metallic pipe or duct, or cables carrying direct current and in some other circumstances.

Proximity voltage testers are not reliable in proving de-energised and should only be treated as an indicator. Proximity voltage testers should be tested for correct operations immediately before use and again immediately after use, particularly if the test result indicates zero voltage, to confirm that the instrument is still working correctly.

## 9.5 PERSONAL PROTECTIVE EQUIPMENT (PPE)

PPE for electrical work, including testing and fault finding, must be suitable for the work, properly tested and maintained in good working order. The PPE must be able to withstand the energy at the point of work when working energised.

Training must be provided in how to select and fit the correct type of equipment, as well as training on the use and care of the equipment so that it works effectively.

Depending on the type of work and the risks involved, the following PPE should be considered:

- *Face Protection*—use of a suitably arc rated full face shield may be appropriate when working where there is potential for high current and arcing.
- *Eye Protection*—metal spectacle frames should not be worn.
- *Gloves*—use gloves insulated to the highest potential voltage expected for the work being undertaken. Leather work gloves may be considered for de-energised electrical work.
- *Clothing*—use non-synthetic clothing of non-fusible material and flame resistant. Clothing made from conductive material or containing metal threads should not be worn.
- *Footwear*—use non-conductive footwear, for example steel toe capped boots or shoes manufactured to a suitable standard.
- *Safety Belt/Harness*—safety belts and harnesses should be checked and inspected each time before use with particular attention being paid to buckles, rings, hooks, clips and webbing.

## 9.6 FIRST AID

All workplaces must ensure the provision of first aid for the workplace, that each worker at the workplace has access to the equipment and access to the facilities for the administration of first aid.

All workplaces must ensure that an adequate number of workers are trained to administer first aid at the workplace or workers have access to an adequate number of other persons who have been trained to administer first aid.

Special requirements for safety observers apply in relation to certain energised electrical work. See Section 0 of this Code.



For further guidance on how to provide first aid refer to the *Code of Practice: First Aid in the Workplace*.

## 10. HIGH VOLTAGE ELECTRICAL WORK

Requirements for electrical work on high voltage equipment after switching, isolation, short circuiting and earthing are specialised requirements. Only competent electrical workers who have received appropriate training in high voltage electrical work are permitted to work on high-voltage electrical equipment.

For more information you should seek further advice about working on or near high-voltage electrical installations from a specialist electrical contractor or the local electricity supply authority.

### ***Additional risks associated with high voltage***

The electrical risks and consequences of an electrical incident involving high voltage may be significantly higher than low voltage. Under fault conditions, the higher voltages (potentials) and fault current levels release massive quantities of energy. These risks must be effectively managed.

### ***Planning for high voltage installation work***

Persons conducting a business or undertaking who have a high voltage electrical installation should prepare an Installation Safety Management Plan for their workplace. The plan should address the risks associated with the operation and maintenance of the high voltage installation.

This may include:

- a single line diagram for the installation, showing all switches and circuit breakers and their identifying labels or numbers
- site-specific operating rules covering all aspects of operating the high voltage installation, including procedures for arranging isolation of the installation from the local electricity network
- procedures for identifying hazardous areas including any confined spaces associated with the installation
- competency requirements for persons who may be permitted to operate or work on the high voltage installation, including appropriate requirements for re-training, re-testing and re-accreditation
- induction procedures for new contractors
- regular inspection and maintenance programs to ensure the installation remains serviceable and safe

- procedures for ensuring there is no extension or alteration of the installation without permission from the local electricity supply authority
- procedures for the safe handling of insulating oils and other substances that may be required for maintenance or repair
- procedures including warning signs for ensuring that all parts of the high voltage installation (e.g. underground cables and high voltage overhead power lines) are not damaged by heavy vehicles or other mobile plant, for example mobile cranes.

## APPENDIX A – MEANING OF KEY TERMS

**Competent person** means:

- for electrical work on energised electrical equipment or energised electrical installations (other than testing referred to in Regulations 150 and 165), a licensed or registered electrician or any other person permitted to carry out or supervise electrical work under relevant State or territory legislation (e.g. electrical engineer, electrical apprentice)
- for any other case, a person who has acquired through training, qualification or experience and the knowledge and skills to carry out the task.

**De-energised** means separated from all sources of supply but not necessarily isolated, earthed, discharged or out of commission.

**Electrical equipment** means any apparatus, appliance, cable, conductor, fitting, insulator, material, meter or wire that:

- is used for controlling, generating, supplying, transforming or transmitting electricity at a voltage greater than extra-low voltage
- is operated by electricity at a voltage greater than extra-low voltage
- is part of an electrical installation located in an area in which the atmosphere presents a risk to health and safety from fire or explosion, or
- is, or is part of, an active impressed current cathodic protection system within the meaning of AS 2832.1:2004.

Electrical equipment does not include any apparatus, appliance, cable, conductor, fitting, insulator, material, meter or wire that is part of a motor car or motorcycle if:

- the equipment is part of a unit of the vehicle that provides propulsion for the vehicle
- the electricity source for the equipment is a unit of the vehicle that provides propulsion for the vehicle.

**Electrical installation** means a group of items of electrical equipment that:

- are permanently electrically connected together
- can be supplied with electricity from the works of an electricity supply authority or from a generating source.

**Energised (live)** means connected to a source of electrical supply or subject to hazardous induced or capacitive voltages.

**Isolated** means disconnected from all possible sources of electricity supply and rendered incapable of being made energised without premeditated and deliberate action.

**Residual current device (RCD)** means a device intended to isolate supply to protected circuits, socket outlets or electrical equipment in the event of a current flow to earth that exceeds a predetermined value. The RCD may be fixed or portable.

**Socket outlet** is a device for detachably connecting electrically operated equipment to a power supply. The term 'socket outlet' includes a cord-extension socket attached to a flexible cord that is permanently connected to installation wiring.

### **Voltage**

- **Extra low voltage** means voltage that does not exceed 50 volts alternating current (50 V a.c.) or 120 volts ripple-free direct current (120 V ripple-free d.c.).
- **Low voltage** means voltage that exceeds extra-low voltage and does not exceed 1000 volts alternating current (1000 V a.c.) or 1500 volts direct current (1500 V d.c.).
- **High voltage** means voltage that exceeds low voltage.

## APPENDIX B – ADVANTAGES AND DISADVANTAGES OF NON-PORTABLE AND PORTABLE RCDS

<b>Non-portable RCDS</b>	Non-portable (or 'fixed') RCDS are installed at either the switchboard or a fixed socket outlet.
<b>Non-portable RCDS installed at the main switchboard</b>	Non-portable RCDS will protect all the wiring and electrical equipment plugged into the relevant circuit(s).
Advantages	<ul style="list-style-type: none"> <li>• provide permanent and secure protection against electrical faults, including protection against fixed-wiring faults as well as electrical equipment faults</li> <li>• are more secure as they are usually inaccessible except to any person who holds the key to the switchboard</li> <li>• may be cost-effective if the existing switchboard can accept the installation without major modification and RCD protection is required on circuits supplied from the main switchboard</li> <li>• are usually adaptable as these RCDS can be installed in new, modified or existing electrical installations.</li> </ul>
Disadvantages	<ul style="list-style-type: none"> <li>• a fault in one piece of equipment may unnecessarily shut down entire operations. In some cases this could create greater risks associated with uncontrolled cessation of a work process</li> <li>• fault detection and isolation may be complex because the RCD protects all sockets past the point where it is installed and may be tripped at any point</li> <li>• installation may be costly if the pre-existing switchboard requires modification.</li> </ul>

<p><b>Non-portable RCDs installed at a socket outlet</b></p>	<p>These non-portable RCDs are installed at selected locations and provide protection to electrical equipment plugged into the outlet.</p> <p>Socket outlets protected by non-portable RCDs should be labelled, for example by stating 'RCD Protected' or similar. This will indicate to the person using the socket outlet that a non-portable RCD is fitted.</p>
<p>Advantages</p>	<ul style="list-style-type: none"> <li>• protection against electrical shock is permanent</li> <li>• suitable for areas where the work environment is used in many different ways or difficult to control, including public places</li> <li>• readily accessible for testing and re-setting. This can be a safe and cost-effective alternative if the switchboard option is not reasonably practical</li> <li>• adaptable, as these RCDs can be installed at any fixed socket outlet where the electrical equipment requiring RCD protection is used</li> <li>• potentially the most cost-effective option because it is permanent, protects everything plugged into it and is easily identified by the user.</li> </ul>
<p>Disadvantages</p>	<ul style="list-style-type: none"> <li>• fixed-wiring protection only applies to wiring past that socket on the circuit</li> <li>• fault detection and isolation might be complicated as the RCD may be tripped by a fault at any point past the RCD on the circuit</li> <li>• damage to the socket outlet will require the RCD to be replaced.</li> </ul>

<p><b>Relevant considerations in deciding between options for non-portable devices</b></p>	<p>In deciding between options for non-portable RCDs, you should consider the size of the building or site, its use, and any plans to refurbish, refit or rewire the building.</p> <p>It may be safer and more cost-effective to ensure all circuits are protected by one or more RCDs rather than selectively install individual RCDs at some socket outlets to accommodate your current workplace needs, which may change.</p> <p>If you install new circuits or modify pre-existing circuits you must protect those circuits with an RCD consistent with AS/NZS 3000:2007, which is subject to some exemptions.</p>
<p><b>Portable RCDs</b></p>	<p>These RCDs protect the electrical equipment that is plugged into them.</p> <p>In some circumstances the most appropriate RCDs may be portable RCDs, particularly to protect mobile workers that do not have fixed places of work and whose PCBU may have little control over electrical installations where they work.</p> <p>Workers using hand-held or portable electrical equipment should be advised as to whether the outlets they use are adequately protected by RCDs. If in doubt you should ensure that portable RCDs are provided to these workers and take all reasonable steps to ensure they are used.</p> <p>The use of a portable RCD in a circuit already protected by a non-portable RCD has no detrimental effect on the operation of either RCD.</p>
<p><b>Portable RCDs—plug type</b></p>	<p>Portable plug-type RCDs can be plugged into a socket outlet to protect a single piece of equipment.</p> <p>They can be incorporated into a power cable or can be the RCD unit alone, without a cord.</p>



Advantages	<ul style="list-style-type: none"> <li>• provide RCD protection for electrical equipment used in workplaces where users may be unsure as to whether there is RCD protection</li> <li>• can be allocated to users rather than to all electrical equipment</li> <li>• can be plugged into existing installations where the electrical equipment requiring protection is to be used.</li> </ul>
Disadvantages	<ul style="list-style-type: none"> <li>• provide no protection from faults in fixed-wiring</li> <li>• may be subject to abuse so frequent testing is required</li> <li>• if not incorporated into a single appliance's power cord, will require additional administrative controls to ensure that workers use them</li> <li>• may be very difficult to test if plug-type RCDs are installed directly onto electrical equipment connection cords. For this reason they are not generally recommended.</li> </ul>
<b>Portable RCDs— portable stand-alone unit</b>	Portable stand-alone units are RCDs incorporated into a power board. They provide multiple protected socket outlets and can provide RCD protection to multiple items of electrical equipment from one power board.
Advantages	<ul style="list-style-type: none"> <li>• provide RCD protection for electrical equipment used in workplaces where users may be unsure as to whether there is RCD protection</li> <li>• can be allocated to users rather than to all electrical equipment</li> <li>• provide a number of protected socket outlets from the one RCD unit</li> <li>• can be plugged into existing installations where the electrical equipment requiring protection is to be used.</li> </ul>

Disadvantages	<ul style="list-style-type: none"><li>• provide no protection from faults in fixed-wiring</li><li>• may be subject to abuse so frequent testing is required</li><li>• rely on administrative controls to ensure that workers use the stand-alone units</li><li>• can be less economical if many items of electrical equipment require protection.</li></ul>
---------------	---

## APPENDIX C – RISKS ASSOCIATED WITH ELECTRICAL WORK

Activity	Risks
<b>Isolation and access</b>	<ul style="list-style-type: none"> <li>• Correctly isolating supply but not discharging residual energy e.g. a capacitive charge may be present in power supplies, single-phase motors or high power factor fluorescent fittings.</li> <li>• Insulation and equipment failing or partially breaking down.</li> <li>• Earth connection failing to stop an electric shock in earthed conductive parts when step and touch potentials exist.</li> <li>• Carrying out the task causes a person, something a person may be handling or something a person is in contact with to intrude into minimum safe approach distances.</li> <li>• A power system conducting fault current or being subject to high inrush currents.</li> <li>• Instructions or markings on the parts being inadequate, incorrect or both.</li> <li>• Using equipment not designed for, or capable of, an operation e.g. opening a 'no load – bus tie' under load conditions or relying on an open circuit breaker as an isolation point.</li> <li>• Another person energising circuits while a worker is working on them, or a vehicle hitting a pole.</li> <li>• Natural elements (i.e. lightning or wind) causing static charges, overhead mains to clash or a high-voltage circuit to fall onto a low-voltage circuit.</li> <li>• The inter-core capacitive effects of long multi-phase cables.</li> <li>• Changes to wiring not being reflected in drawings i.e. the drawings are not 'as built' e.g. a live control or supervision circuit being present though the drawing</li> </ul>

Activity	Risks
	<p>indicates otherwise.</p> <ul style="list-style-type: none"> <li>• If there has been an error in wiring, opening the isolator may not de-energise the switchboard e.g. if incorrect connection (incorrect polarity) occurred in the service to an installation, opening the main switch will open circuit the neutral rather than the active.</li> <li>• Intentionally disabling an interlock to perform a task e.g. opening the shutter of a 'rackable' circuit breaker test to prove de-energised in the orifice.</li> <li>• Inadvertently disabling an interlock while performing a task e.g. in a switchboard with an integrated circuit breaker, isolator and earth switch, the operator accidentally moving the isolator into the earthed position.</li> <li>• Poor direction and insufficient knowledge e.g. a worker is instructed to apply a set of earths and short circuits at a Ring Main Unit (RMU). The worker correctly observes the isolator is open, however they assume the earth switch can be closed because the isolator is open. As most RMUs are configured so the earth switch earths the cable, not the busbar, it is possible the worker would be earthing and short-circuiting a live circuit.</li> <li>• When applying a set of portable earths and short-circuits, accidental or inadvertent contact is made with live parts. If this occurs, the worker is using a device that is conducting fault current.</li> <li>• The threshold value (lowest level of indication or reading) of a test device causing a misleading interpretation of a test to prove de-energised. Depending on the device used, an indication that parts are not energised in a high-voltage situation does not mean that low-voltage and direct current voltages are absent.</li> </ul>

Activity	Risks
	<ul style="list-style-type: none"> <li>• Application of earthing and short-circuiting devices that depend on a conductive path through a fuse or circuit breaker that is not fit for purpose.</li> <li>• Ineffective connection to the general mass of the earth e.g. the electrode, grid or temporary electrode that the earth and short circuits relies upon in a situation where a single phase becomes energised.</li> <li>• Application of the short circuit portion of portable earthing devices prior to the earth tail being connected to the earth.</li> <li>• Arcing and splattering associated with the application of earths and short circuits, causing a risk. The arcing or splattering may result from using the device in situations that range from energised conductors to residual energy such as capacitance. If the parts are energised, the worker can draw the arc from one phase to the other, causing a phase-to-phase fault.</li> <li>• A potential electric shock path existing once the earth tail is connected to earth. A worker may touch another live part and the earthed connector at the same time, for example in a Common Multiple Earthed Neutral (CMEN) area, even when working on high-voltage, contact between the earthed connector and a low-voltage phase can cause an electric shock.</li> </ul>
<p><b>Working near sources of arcing, explosion or fires</b></p>	<p>Arcs, explosions and electrical faults can cause burns. Workers should be protected from the effects of burns. Examples include:</p> <ul style="list-style-type: none"> <li>• materials providing a conductive path between sources of potential, for example uninsulated tools falling across busbars</li> <li>• abnormal conditions on circuits such as: <ul style="list-style-type: none"> <li>○ lightning striking mains</li> <li>○ circuits of different voltages touching each other e.g. high-voltage</li> </ul> </li> </ul>

Activity	Risks
	<p>contacting low-voltage circuits</p> <ul style="list-style-type: none"> <li>○ high voltage in the secondary circuit of a current transformer if an open circuit occurs when current is flowing in the primary circuit.</li> <li>• abnormally high voltages when synchronising different supplies. For example, if the waveforms are 180° out of phase, twice the peak-to-peak voltage may be imposed</li> <li>• voltage multiplication effects, including: <ul style="list-style-type: none"> <li>○ ferro-resonance where the capacitive and inductive components of underground cables and transformers can significantly increase voltages when single-phasing occurs</li> <li>○ re-strike can occur if capacitors are energised, de-energised and re-energised in rapid succession</li> </ul> </li> <li>• leakage or electrical discharge causing insulation to be compromised, for example a combination of a build-up of contaminants on insulators, wet weather or tracking through air voids in pitch filled insulating chambers</li> <li>• failure of insulating mediums.</li> </ul>
<b>Working in unsafe atmospheres</b>	<p>After faults and fires, often in emergencies, electrical workers may be exposed to unsafe atmospheres. Toxic gases and lack of oxygen can cause illness and death. General workplace health and safety risk control measures should be used in these situations.</p> <p>The method of extinguishing fires should be addressed. Typically, carbon dioxide or powder type devices are used against electrical fires. Extinguishers including water, foam and wet chemical should not be used as they significantly increase the risk of electric shock.</p>
<b>Modifying or repairing existing low-voltage</b>	<ul style="list-style-type: none"> <li>• Electrical drawings/tables not reflecting 'as installed' installations.</li> <li>• More than one source of supply or</li> </ul>

Activity	Risks
<b>electrical installations</b>	<p>energised circuit may be available on the premises or at the equipment.</p> <ul style="list-style-type: none"> <li>• The supply becoming energised during the work.</li> <li>• Automatic starting of machinery after supply is restored.</li> <li>• Managing metallic shavings (swarf) ingress into conductive parts of equipment.</li> <li>• A conductor considered to be de-energised was found to be energised.</li> <li>• Old installations (where several modifications may have been made, circuits have not been identified, or the insulation has deteriorated).</li> <li>• Voltages on disconnected conductors, particularly neutrals.</li> <li>• Installations where the MEN system is used, the rise in the earth potential due to a high impedance return path to the distribution neutral.</li> <li>• Lack of information about isolation, sources of supply or the location of electrical conductors.</li> <li>• Lack of clear safe access to locate electric cables (other hazards may be present such as exposed conductors).</li> <li>• Damage to conductors in metallic conduits where earthing continuity of the conduit has not been maintained.</li> <li>• Equipment located in hazardous areas, which includes bolt-on or screw-on covers, can be dangerous if opened without obtaining specialist advice.</li> <li>• Working alone on energised equipment.</li> <li>• Drilling into switchboards/electrical enclosures.</li> <li>• Contact with cables in walls, floors or roof spaces.</li> <li>• Contact with cables during excavation</li> </ul>

Activity	Risks
	<p>work or cutting/drilling concrete.</p> <ul style="list-style-type: none"> <li>• Exposure to asbestos material/switchboards.</li> <li>• Variable frequency devices.</li> <li>• Multiple circuits located within the one conduit.</li> <li>• Use of conductive/flammable cleaning solvents creating an explosive atmosphere.</li> </ul>
<p><b>Testing and fault finding low-voltage equipment and installations</b></p>	<p>Risks arise as it is difficult to find faults or malfunctions in electrical equipment when the circuits are not energised or when the equipment is not operating, especially if feedback circuits or sensors are involved. Risks can include:</p> <ul style="list-style-type: none"> <li>• electrical drawings/tables not reflecting 'as installed' installations</li> <li>• exposed energised terminals or conductors</li> <li>• terminals or conductors being energised under different conditions of operation of the equipment</li> <li>• loose or disconnected test leads or wiring becoming energised</li> <li>• test equipment and leads bringing electrical hazards closer to the worker</li> <li>• test equipment inappropriate for the task (particularly test probes)</li> <li>• inadequate test points</li> <li>• inadvertent attempts to start machinery by other persons</li> <li>• incorrect or poorly maintained testing instruments</li> <li>• inadequate knowledge of equipment or causes of faults</li> <li>• lack of information about circuits or equipment</li> <li>• equipment located in hazardous areas, which includes bolt-on or screw-on covers,</li> </ul>



Activity	Risks
	<p>can be dangerous if opened without obtaining specialist advice</p> <ul style="list-style-type: none"> <li>• testing or fault finding alone on energised equipment</li> <li>• testing or fault finding in cramped or restricted work situations</li> <li>• rotating or moving machinery (crush hazards)</li> <li>• overriding of interlocks or forcing of control equipment</li> <li>• re-setting of protective devices in energised switchboards</li> <li>• electrical installations where unauthorised electrical work has been undertaken.</li> </ul>
<p><b>High fault currents – working, testing or fault finding energised</b></p>	<p>When working, testing or fault finding on energised electrical equipment, a fault current of up to 20 times the rated current of the supply transformer can flow for short duration during fault conditions.</p> <p>Arcs can have the energy to cause an explosion and/or melt metallic switchboard cubicles and equipment. Arcs may cause severe burns to the skin and flash burns to the face and eyes. Inhaled hot gases and molten particles can cause serious internal burns to the throat and lungs. Injury can also occur through the impact from flying debris and dislodged components. Circuit protection devices may not operate in such circumstances.</p>
<p><b>Testing, fault finding or working on or near low voltage equipment</b></p>	<ul style="list-style-type: none"> <li>• Voltages between phases and between phases and neutral.</li> <li>• Voltages between phases and earth.</li> <li>• Voltages across open switch contacts, for example voltage across a light switch on an incandescent lighting circuit or the voltage across a bus tie where one side is de-energised.</li> <li>• Voltages on disconnected conductors (particularly neutrals).</li> <li>• Voltages from sources near the work</li> </ul>

Activity	Risks
	<p>being performed, for example:</p> <ul style="list-style-type: none"> <li>○ working on a remote area power supply where both a.c. and d.c. voltages may be present</li> <li>○ repairing lights on a shop fascia when overhead power lines are nearby</li> <li>○ working on transducer circuits when other a.c. and d.c. circuits are present</li> <li>○ working on a power system with multiple circuits that may be of multiple potentials.</li> </ul> <ul style="list-style-type: none"> <li>● Voltages on the circuit being worked on from other sources including: <ul style="list-style-type: none"> <li>○ illegal connections or reconnections</li> <li>○ Uninterruptible Power Supplies (UPS) and backup supplies</li> <li>○ motor generators or alternators</li> <li>○ d.c. on a.c. circuits or a.c. on d.c. circuits</li> <li>○ harmonics, for example 3rd harmonic 150 Hz in neutrals and earths where there is a large fluorescent light load and switch mode power supplies</li> <li>○ back Electro Magnetic Forces (EMF) from collapsing magnetic fields or rotating machinery</li> <li>○ solar panels or photovoltaic.</li> </ul> </li> <li>● Voltages across undischarged capacitors.</li> <li>● Voltages across the secondary terminals of transformers, including current transformers.</li> <li>● Voltages caused by static electricity, leakage or discharge, or lightning.</li> <li>● Voltages between energised exposed conductors and the surrounding environment (including metalwork, damp situations, other conductive surfaces and persons nearby).</li> <li>● Voltages between parts, or open-circuited</li> </ul>

Activity	Risks
	<p>parts of one earth system, or voltages between different earthing systems.</p> <ul style="list-style-type: none"> <li>• Induced voltages from sources other than the circuit being worked on, for example nearby circuits or radio frequency transmitters.</li> <li>• Multiple supply sources (more than one source of supply or energised circuit may be available on the premises), for example 'essential services' on a switchboard, emergency backup generators or UPS.</li> <li>• Electrical testing or operating equipment with open enclosures in hazardous areas (as defined by AS/NZS 3000:2007).</li> <li>• The potential (voltage) between parts of the earth in Multiple Earthed Neutral (MEN) systems can change, sometimes causing electric shocks. The changing earth potential can be due to a number of causes including a high impedance return path to the low-voltage distribution neutral, faults on other parts of the power system or lightning strikes.</li> <li>• Incorrect wiring connections, for example transposing active and neutral, commonly referred to as incorrect polarity.</li> <li>• Switched off circuits becoming energised.</li> <li>• Faulty equipment, for example the frame of faulty equipment may become energised.</li> <li>• Step and touch potentials and transferred earth potentials. Transferred earth potentials often result from system faults.</li> <li>• Hygroscopic materials that become conductive, for example fertiliser dust.</li> </ul>
<p><b>Other Hazards</b></p>	<ul style="list-style-type: none"> <li>• Working at heights and danger of falling objects.</li> <li>• Removal of cover plates near energised equipment, for example escutcheon plates.</li> </ul>

Activity	Risks
	<ul style="list-style-type: none"> <li>• Confined spaces (where there may be a hazardous atmosphere).</li> <li>• Inadequate light to work safely.</li> <li>• Lack of ventilation leading to uncomfortable, hot and humid working conditions.</li> <li>• Excessive worker fatigue, due to pressure of deadlines or other factors.</li> <li>• Obstacles to getting the equipment switched off.</li> <li>• Using a gas flame near exposed electrical conductors (a flame is a conductor).</li> <li>• Using conductive or flammable cleaning solvents.</li> <li>• Temperature rise as a result of combustion.</li> <li>• Cramped working conditions, including cable trenches and cable pits.</li> <li>• Explosive atmospheres.</li> <li>• Use of conductive tools and equipment, for example metallic tape measures and rulers.</li> <li>• Electric tools and equipment (for example, hand lamps, drills, saws, torches and test instruments).</li> <li>• Personal effects (for example, rings, jewellery, watches, pens, cigarette lighters, matches, hearing aids, mobile phones and pagers, transistor radios and similar).</li> <li>• General work activities (for example, welding, cutting, brazing, using hand saws, drilling of all types, hammering and chiselling).</li> <li>• Hot metal surfaces due to drilling, grinding or welding.</li> <li>• Excavation associated with electrical work.</li> <li>• Molten metal from arcs.</li> <li>• Asbestos material/switchboards.</li> </ul>

Activity	Risks
	<ul style="list-style-type: none"><li data-bbox="576 250 1321 360">• Polychlorinated biphenyl (PCB) in transformers, capacitors and electric motors.</li></ul>

## APPENDIX D – PREVENTATIVE ACTIONS CHECKLIST

This checklist will help you to identify hazards associated with electrical work and develop safe work methods.

If you answer 'NO' to any question you must take action to put appropriate risk control measures in place.

PART 1: INITIAL ASSESSMENT	Y	N
<p>Can the work be undertaken while the electrical equipment is de-energised?</p> <p><i>If Yes, proceed to Part 2. If No, is it:</i></p> <ul style="list-style-type: none"> <li>• necessary in the interests of health and safety that the electrical work is carried out on the equipment while the equipment is energised?</li> </ul> <p><b>OR</b></p> <ul style="list-style-type: none"> <li>• necessary that the electrical equipment to be worked on is energised in order for the work to be carried out properly?</li> </ul> <p><b>OR</b></p> <ul style="list-style-type: none"> <li>• is it necessary for the purposes of electrical testing required under Regulation 155?</li> </ul> <p><b>OR</b></p> <ul style="list-style-type: none"> <li>• are there no reasonable alternative means of carrying out the work?</li> </ul> <p><i>If your answer to any of these is 'yes' proceed to Part 3 after considering whether part of the installation or equipment may be de-energised while the work is carried out.</i></p> <p><i>If you cannot answer 'yes' to any of these proceed to Part 2—you must work de-energised.</i></p>		
PART 2: WORK DE-ENERGISED	Y	N
<ul style="list-style-type: none"> <li>• Do you have approved test instruments suitable for the task?</li> </ul>		

<ul style="list-style-type: none"> <li>• Have you checked that the test instruments are functioning correctly?</li> <li>• Have you isolated the supply e.g. by switching off?</li> <li>• Have you conclusively tested that the equipment is de-energised? <ul style="list-style-type: none"> <li>▪ <i>You must carry out the electrical work in accordance with any safe work method statement that must be prepared for the work.</i></li> </ul> </li> </ul> <p><i>Proceed to Part 4.</i></p>		
<b>PART 3: WORK ON OR NEAR ENERGISED EQUIPMENT</b>	<b>Y</b>	<b>N</b>
Has a risk assessment been conducted by a competent person which identifies all electrical hazards and non-electrical hazards, both actual and potential?		
Is the work area clear of obstructions to allow for easy access?		
Is the isolation point clearly marked or labelled and capable of being operated quickly?		
Has the person with management or control of the workplace been consulted about the proposed electrical work?		
Do you have a safe work method statement for the task at hand? This should state the control measures required to eliminate or minimise the risks.		
Are you trained, competent and confident in applying the particular procedures or techniques that are required for the task?		
Have you checked to ensure that your tools and accessories are insulated and have been inspected and maintained to ensure they are serviceable?		
Is your test equipment appropriate to the task and functioning correctly?		
Are you wearing the appropriate clothing and associated PPE for the task e.g. safety helmet and boots, insulating gloves?		
Do you have the appropriate insulating mats and sheeting?		

Is a safety observer present? <i>Note: a safety observer is not required for electrical work if it only involves testing and the risk assessment shows that there is no serious risk associated with the work.</i>		
Are the necessary first aid facilities provided and accessible and are unauthorised persons prevented from entering the work area?		
<b>REMEMBER:</b> <ul style="list-style-type: none"> <li>• Do the work very carefully.</li> <li>• Follow the safe work procedures.</li> <li>• Assume all exposed conductors are energised.</li> <li>• Be aware of the voltage to earth of all exposed conductors.</li> </ul>		
<b>PART 4: AFTER COMPLETING THE WORK</b>	<b>Y</b>	<b>N</b>
Have the installations/circuits/equipment been restored to a safe and operable condition?		
Have all tags and locking-off devices been removed?		