



Vehicle Standard (Australian Design Rule 42/04 – General Safety Requirements) 2005 Amendment 5

I, PAUL FLETCHER, Minister for Territories, Local Government and Major Projects, determine this vehicle standard under section 7 of the *Motor Vehicle Standards Act 1989*.

Dated 1 February 2016

[SIGNED]

Paul Fletcher

Minister for Territories, Local Government and Major Projects

CONTENTS

1. LEGISLATIVE PROVISIONS	3
2. AMENDMENT OF VEHICLE STANDARD	3
SCHEDULE 1	3

1. LEGISLATIVE PROVISIONS

- 1.1. Name of Legislative Instrument
 - 1.1.1. This instrument is the Vehicle Standard Australian Design Rule 42/04 – General Safety Requirements 2005 Amendment 5
- 1.2. Commencement
 - 1.2.1. This instrument commences on the day after it is registered.

2. AMENDMENT OF VEHICLE STANDARD

- 2.1. The changes specified in Schedule 1 amend Vehicle Standard (Australian Design Rule 42/04 – General Safety Requirements) 2005.

SCHEDULE 1

- [1] Amend paragraph 4.1. to read:

“Refer to Vehicle Standard (Australian Design Rule Definitions and Vehicle Categories) 2005.”

- [2] Amend paragraph 19.3.2.6.4. to read:

“The technical requirements of FMVSS 118-FR VOL36 No. 232-02.12.1971- Power Operated Window System; as amended by FMVSS 118-FR VOL58 No. 60-31.03.1993 are deemed to be equivalent to the technical requirements of clause 19.3 of this national standard.”

- [3] Insert new paragraph 21.1. to read:

“The Static Stability Ratio (SSR) of a three-wheeled vehicle is defined as the ratio of the Centre of Mass (CoM) height (h) (see Figure 3) with the horizontal distance from the CoM to the nearest roll axis (d) (see figure 4a and 4b) under the specified loading state (the ‘*Maximum Loaded Test Mass*’). A roll axis is a line joining the centre-point of each tyre’s contact patch (see Figures 4a and 4b).”

- [4] Renumber previous paragraphs 21.1. and 21.2. to 21.2. and 21.3. respectively.

- [5] Amend paragraph 21.2. to read:

“For LEM1, LEP1 & LEG1 vehicles the SSR shall not exceed 1.0.”

- [6] Amend paragraph 21.3. to read:

“For LEM2, LEP2 & LEG2 vehicles the SSR shall not exceed 1.5.”

- [7] Insert new paragraph 21.4 to read:

“LEM1 vehicles fitted with a rear axle having a ‘*Differential*’, excluding those vehicles fitted with a ‘*Limited-Slip Differential*’, complying with the technical requirements of the Canadian Motor Vehicle Safety

Standard No. 505 Vehicle Stability, current as at 2007, shall be deemed to comply with the clauses 21.2.”

[8] Renumber previous paragraph 21.3. to 21.5. (including sub-clauses).

[9] Amend paragraph 21.5.1. to read:

“Unless otherwise ‘*Approved*’, the location of the vehicle’s centre of mass shall be determined by the methods described below. Manufacturers may select between the Stable Pendulum Method (paragraph 21.5.4.) and the Axle Lift Method (paragraph 21.5.6.) for determining the height of the CoM.”

[10] Amend paragraph 21.5.3. to read:

“Longitudinal location (See Figures 3, 4a and 4b)”

[11] Amend paragraph 21.5.4. to read:

“Height Location – Stable Pendulum Method (See Figure 3)”

[12] Amend paragraph 21.5.4.7. to read:

“Measure the angle between the reference line and the horizontal (See Figure 5). An inaccuracy of 0.1 degrees measured inclination results in an inaccuracy in the SSR of approximately 0.0025 in the SSR range of interest (SSR between 1.0 and 1.5, an inaccuracy of 0.16% to 0.25%).”

[13] Insert new paragraph 21.5.6. to read:

“Height Location – Axle Lift Method”

[14] Insert new paragraph 21.5.6.1. to read:

“This test procedure requires the ability to accurately measure the height of elevation of the single-wheel axle, and accurately measure the ‘*Axle Load*’ (or axle weight) of the two-wheel axle (see paragraph 21.5.6.1.3. below). The test report shall take account of potential and known inaccuracies in measurement equipment, especially where the SSR nears the compliance limit.”

[15] Insert new paragraph 21.5.6.1.1. to read:

“An inaccuracy of 5mm in the measurement of the height of elevation of the single-wheel axle results in an inaccuracy in the SSR of approximately 0.009 in the SSR range of interest (SSR between 1.0 and 1.5, an inaccuracy of 0.6% to 0.9%), whilst an inaccuracy of 1kg in the measurement of the weight over the two-wheel axle will result in an inaccuracy in the SSR of approximately 0.023 in the SSR range of interest (SSR between 1.0 and 1.5, an inaccuracy of 1.7% to 2.5%).”

[16] Insert new paragraph 21.5.6.1.2. to read:

These accuracy sensitivities should be considered in the context of the sensitivity of the stable pendulum test method at paragraph 21.5.4.

[17] Insert new paragraph 21.5.6.1.3. to read:

“Total mass is the same in the elevated position as in the normal position.

$$F + R = F_e + R_e = \text{total mass}$$

Where:

R_e is the rear ‘*Axle Load*’ on the tyre(s) with the elevated vehicle in the ‘*Maximum Loaded Test Mass*’ condition; and

F_e is the front ‘*Axle Load*’ on the tyre(s) with the elevated vehicle in the ‘*Maximum Loaded Test Mass*’ condition.

Once the total mass is known at the ‘*Maximum Loaded Test Mass*’ condition (measured prior to elevation), it is only necessary to measure the two-wheel axle ‘*Axle Load*’ to determine the other ‘*Axle Load*’.”

[18] Insert new paragraph 21.5.6.2. to read:

“Height Location for LEM1, LEP1 and LEG1 Category Vehicles (See Figures 3 and 6)”

[19] Insert new paragraph 21.5.6.2.1. to read:

“The height of the CoM shall be determined as follows:”

[20] Insert new paragraph 21.5.6.2.2. to read:

“With the suspension blocked to prevent movement and the vehicle in the ‘*Maximum Loaded Test Mass*’ condition, use blocks to elevate the front to not less than 600 mm (H_{fe}), and determine the longitudinal location of the CoM in the elevated state (L_e), from the centre line of the front ‘*Axle*’, using the formula:

$$L_e = W_e R_e / (F_e + R_e)$$

Where:

W_e is the wheelbase in the horizontal plane.”

[21] Insert new paragraph 21.5.6.2.3. to read:

“The height of the CoM is given by the formula:

$$h = [(W - L) / \tan \theta - (W_e - L_e) / \sin \theta] + r$$

Where:

L_e is defined by the formula in 3.2.2 above;

θ is defined by the formula:

$$\theta = \arctan (H_{fe} / W_e)$$

H_{fe} is the height by which the front wheel is elevated;
 r is the rolling radius of the tyre fitted to the rear wheel;
 W is the wheelbase of the vehicle prior to elevation; and
 L is the longitudinal location of the CoM prior to elevation
(determined in clause 21.5.3.1).”

[22] Insert new paragraph 21.5.6.3. to read:

“Height Location for LEM2, LEP2 and LEG2 Category Vehicles (See Figures 3 and 7):”

[23] Insert new paragraph 21.5.6.3.1. to read:

“The height of the CoM shall be determined as follows:”

[24] Insert new paragraph 21.5.6.3.2. to read:

“With the suspension blocked to prevent movement and the vehicle in the ‘*Maximum Loaded Test Mass*’ condition, use blocks to elevate the rear to not less than 600 mm (H_{re}), and determine the longitudinal location of the CoM in the elevated state (L_e), from the centre line of the front ‘Axle’, using the formula:

$$L_e = W_e R_e / (F_e + R_e)$$

Where:

W_e is the wheelbase in the horizontal plane;

R_e is the rear ‘*Axle Load*’ on the tyre(s) with the elevated vehicle in the ‘Test Mass’ condition; and

F_e is the front ‘*Axle Load*’ on the tyre(s) with the elevated vehicle in the ‘Test Mass’ condition.”

[25] Insert new paragraph 21.5.6.3.3. to read:

“The height of the CoM is given by the formula:

$$h = [(L / \tan \theta) - (L_e / \sin \theta)] + r$$

Where:

L_e is defined by the formula above;

θ is defined by the formula:

$$\theta = \arctan (H_{re} / W_e)$$

H_{re} is the height by which the rear wheel is elevated;

r is the rolling radius of the tyre fitted to the front wheel; and

L is the longitudinal location of the CoM prior to elevation
(determined in clause 21.5.3.1).”

[26] Replace Figure 3 with:

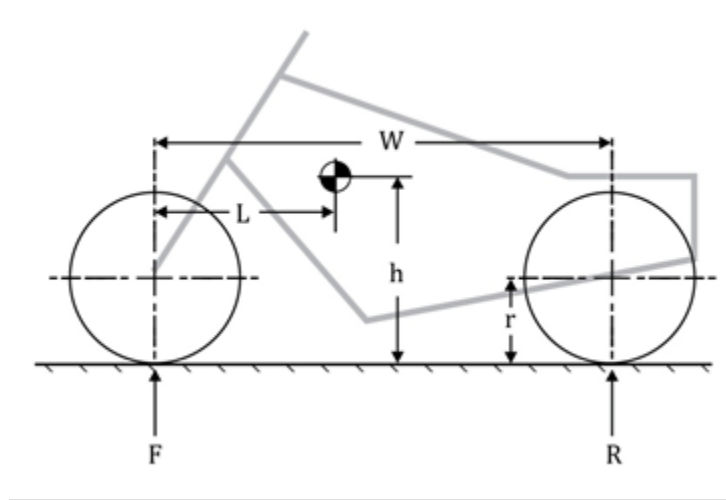

Figure 3 – Side View

[27] Insert new Figure, Figure 4a:

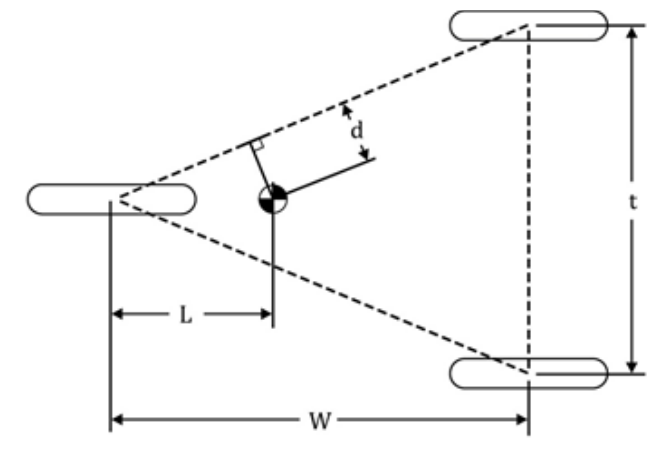

Figure 4a – Plan View, LEM1, LEP1 and LEG1

[28] Insert new Figure, Figure 4b:

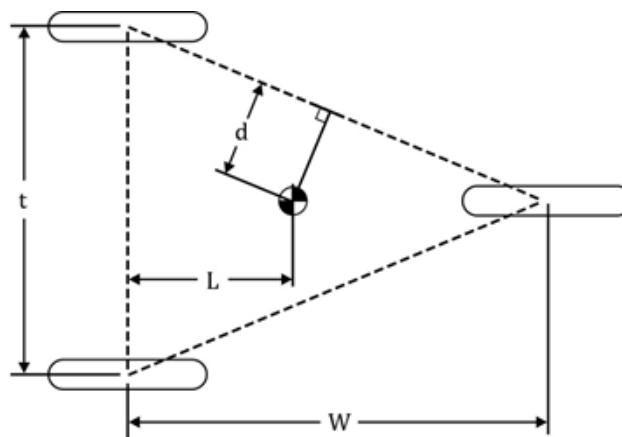

Figure 4b – Plan View, LEM2, LEP2 and LEG2

[29] Renumber Figure 4 as Figure 5.

[30] Delete previous Figure 5.

[31] Insert new Figure 6:

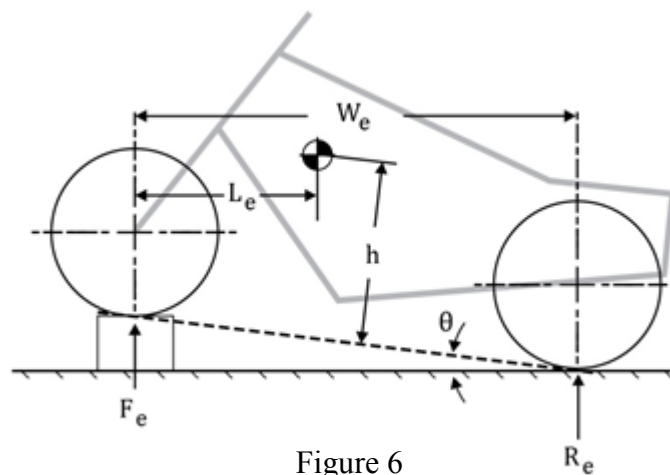

Figure 6

[32] Insert new Figure 7:

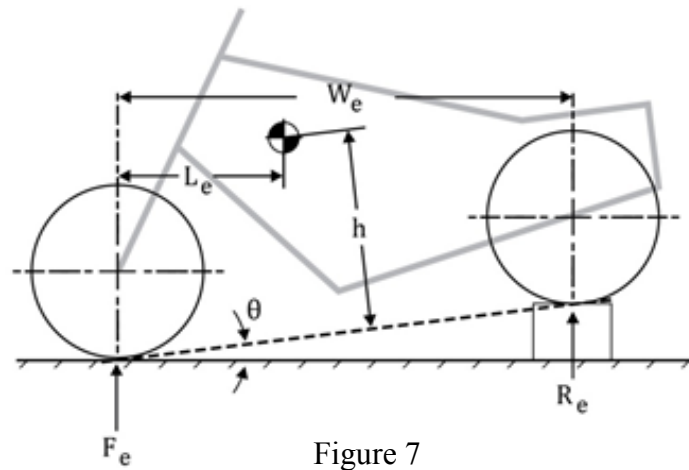

Figure 7

[33] Renumber previous Figure 6 as Figure 8.