



Vehicle Standard (Australian Design Rule 84/00 – Front Underrun Impact Protection) 2009 Amendment 1

I, PAUL FLETCHER, Minister for Urban Infrastructure, determine this vehicle standard under section 7 of the *Motor Vehicle Standards Act 1989*.

Dated 18/11/2017

(SIGNED)

Paul Fletcher

Minister for Urban Infrastructure

CONTENTS

1.	LEGISLATIVE PROVISIONS	3
2.	AMENDMENT OF VEHICLE STANDARD	3
	SCHEDULE 1.....	4
	SCHEDULE 2.....	6

1. LEGISLATIVE PROVISIONS

- 1.1. Name of Legislative Instrument
 - 1.1.1. This instrument is the Vehicle Standard (Australian Design Rule 84/00 – Front Underrun Impact Protection) 2009 Amendment 1.
- 1.2. Commencement
 - 1.2.1. This instrument commences on the day after it is registered.

2. AMENDMENT OF VEHICLE STANDARD

- 2.1. The changes specified in Schedule 1 amend Vehicle Standard (Australian Design Rule 84/00 – Front Underrun Impact Protection) 2009.

SCHEDULE 1

[1] Amend Clause 6.1. to read:

“6.1. Compliance with the following parts, sections and annexes of Appendix A is not required for the purposes of this standard:

Section 4	Application for approval
Section 5	Approval of an FUPD
Section 7	Approval of installation of an approved FUPD
Section 8	Requirements for installation of an Approved FUPD, paragraphs 8.1, 8.2, 8.3, 8.4, and 8.6
Section 9	Approval of a vehicle with FUP

Annexes

Annex 1	Communication concerning the approval or extension or refusal or withdrawal of approval or production definitely discontinued of a type of Front Underrun Protection Device (FUPD) pursuant to Regulation No. 93 (Part I)
Annex 2	Communication concerning the approval or extension or refusal or withdrawal of approval or production definitely discontinued of a vehicle type with regard to the installation of a Front Underrun Protection Device (FUPD) of an approved type pursuant to Regulation No. 93 (Part II)
Annex 3	Communication concerning the approval or extension or refusal or withdrawal of approval or production definitely discontinued of a vehicle with regard to its front underrun protection (FUP) pursuant to Regulation No. 93 (Part III)
Annex 4	Arrangements of approval marks
Annex 6	Conformity of production and other administrative procedures”

[2] Add Clause 6.2. to read:

“6.2. Compliance with paragraph 6.4 of Appendix A is not required for the purposes of this standard.”

[3] Add Clause 6.3. to read:

“6.3. Paragraph 10.5 of Appendix A is to be read as meaning the foremost part of the vehicle may only be taken to be those parts of the vehicle that are directly in line with each applied test force.”

[4] Add Clause 6.4. to read:

“6.4. Paragraph 3.4 of Annex 5 to Appendix A shall be read as requiring the highest placement to be recorded, but that it need not be recorded on a “communication document”.

[5] Add Clause 6.5. to read:

“6.5. Paragraph 3.5.2. of Annex 5 to Appendix A shall be read as requiring that the rams that apply specified forces need not be articulated, provided that they do not restrict any vertical or transverse displacement of the FUPD or FUP.”

[6] Amend Clause 7.1. to read:

“7.1. The technical requirements adopted by the United Nations Regulation No. 93 – UNIFORM PROVISIONS CONCERNING THE APPROVAL OF:
I. FRONT UNDERRUN PROTECTIVE DEVICES (FUPDs)
II. VEHICLES WITH REGARD TO THE INSTALLATION OF AN FUPD OF AN APPROVED TYPE
III. VEHICLES WITH REGARD TO THEIR FRONT UNDERRUN PROTECTION (FUP)
incorporating the 00 series of amendments, shall be deemed to be equivalent to the technical requirements of this standard.”

SCHEDULE 2

[1] Delete Appendix A and replace with:

“APPENDIX A

AGREEMENT

CONCERNING THE ADOPTION OF UNIFORM CONDITIONS OF APPROVAL AND RECIPROCAL RECOGNITION OF APPROVAL FOR MOTOR VEHICLE EQUIPMENT AND PARTS

done at Geneva on 20 March 1958

Addendum 92: Regulation No. 93

Date of entry into force: 27 February 1994

UNIFORM PROVISIONS CONCERNING THE APPROVAL OF:

- I. FRONT UNDERRUN PROTECTIVE DEVICES (FUPDs)**
- II. VEHICLES WITH REGARD TO THE INSTALLATION OF AN FUPD OF AN APPROVED TYPE**
- III. VEHICLES WITH REGARD TO THEIR FRONT UNDERRUN PROTECTION (FUP)**



UNITED NATIONS

Regulation No. 93

UNIFORM PROVISIONS CONCERNING THE APPROVAL OF:

- I. FRONT UNDERRUN PROTECTIVE DEVICES (FUPDs)
- II. VEHICLES WITH REGARD TO THE INSTALLATION OF AN FUPD OF AN APPROVED TYPE
- III. VEHICLES WITH REGARD TO THEIR FRONT UNDERRUN PROTECTION (FUP)

CONTENTS

1. SCOPE
2. PURPOSE
3. DEFINITIONS
4. APPLICATION FOR APPROVAL

PART I. APPROVAL OF FUPDs

5. APPROVAL OF FRONT UNDERRUN PROTECTIVE DEVICES (FUPDS)
6. REQUIREMENTS FOR FUPDs

PART II. APPROVAL OF A VEHICLE WITH REGARD TO THE INSTALLATION OF AN FUPD OF AN APPROVED TYPE

7. APPROVAL OF THE INSTALLATION OF AN APPROVED FUPD
8. REQUIREMENTS FOR THE INSTALLATION OF AN APPROVED FUPD

PART III. APPROVAL OF A VEHICLE WITH REGARD TO ITS FRONT UNDERRUN PROTECTION (FUP)

9. APPROVAL OF A VEHICLE WITH FUP
10. REQUIREMENTS FOR A VEHICLE WITH FUP

ANNEXES

- Annex 1 - Communication concerning the approval or extension or refusal or withdrawal of approval or production definitely discontinued of a type of front underrun protection device (FUPD) pursuant to Regulation No. 93 (Part I)
- Annex 2 - Communication concerning the approval or extension or refusal or withdrawal of approval or production definitely discontinued of a vehicle type with regard to the installation of a front underrun protection device (FUPD) of an approved type pursuant to Regulation No. 93 (Part II)
- Annex 3 - Communication concerning the approval or extension or refusal or withdrawal of approval or production definitely discontinued of a vehicle with regard to its front underrun protection (FUP) pursuant to Regulation No. 93 (Part III)
- Annex 4 - Arrangements of approval marks
- Annex 5 - Test conditions and procedures
- Annex 6 - Conformity of production and other administrative procedures

Regulation No. 93

UNIFORM PROVISIONS CONCERNING THE APPROVAL OF:

- I. FRONT UNDERRUN PROTECTIVE DEVICES (FUPDs)**
- II. VEHICLES WITH REGARD TO THE INSTALLATION OF AN FUPD OF AN APPROVED TYPE**
- III. VEHICLES WITH REGARD TO THEIR FRONT UNDERRUN PROTECTION (FUP)**

1. SCOPE

- 1.1. This Regulation applies to:
 - 1.1.1. PART I: the FUPDs which are intended to be fitted to vehicles of categories N₂ and N₃¹
 - 1.2. PART II: the installation on vehicles of categories N₂ and N₃¹ of FUPDs which have been type approved to Part I of this Regulation;
 - 1.2.1. PART III: vehicles of categories N₂ and N₃ with regard to its front underrun protection (FUP), equipped with an FUPD, which has not been separately approved according to Part I of this Regulation or so designed and/or equipped that their component parts can be regarded as fulfilling the function of the FUPD.
 - 1.3. Vehicles of categories N₂ with a maximum mass not exceeding 7.5 tonnes shall comply only with the ground clearance requirement of 400 mm set out in this Regulation.
 - 1.4. The requirements of this Regulation do not apply to:
 - 1.4.1. off-road vehicles of categories N₂G and N₃G¹
 - 1.4.2. vehicles such that their use is incompatible with the provisions of front underrun protection.

2. PURPOSE

The purpose of this Regulation is to offer effective protection for vehicles of category M₁ or N₁¹ against underrunning of vehicles mentioned in paragraph 1 of this Regulation in the event of a frontal collision.

3. DEFINITIONS

- 3.1. For the purpose of this Regulation:
 - 3.1.1. "Maximum mass" of the vehicle means the mass stated by the vehicle manufacturer to be the maximum technically permissible (this may be higher than the "permissible maximum mass" laid down by the national administration);
 - 3.1.2. "Maximum weight" of the vehicle means the vertical force (in newtons) required to support the same vehicle loaded to its maximum mass;

¹ See Consolidated Resolution on the Construction of Vehicles (R.E.3, annex 7) (TRANS/SC1/WP29/78/Amend.3).

- 3.1.3. "Unladen vehicle" means the vehicle in running order unoccupied and unladen but complete with fuel, coolant, lubricant, tools and a spare wheel (if provided as standard equipment by the vehicle manufacturer);
- 3.1.4. "Approval of an FUPD" means the approval of such a type of FUPD with respect to the requirements laid down in paragraph 7 below;
- 3.1.5. "Type of FUPD" means FUPD, which do not differ with respect to the essential characteristics such as shape, dimensions, attachment, materials and the markings cited in paragraph 4.2. below;
- 3.1.6. "Front underrun protection (FUP)" means the presence at the front of the vehicle of either:
- 3.1.6.1. A special device (FUPD); or
- 3.1.6.2. Body work, chassis parts or other components, such that by virtue of their shape and characteristics, these elements can be regarded as fulfilling the function of the FUPD;
- 3.1.7. "Approval of a vehicle" means the approval of a vehicle type:
for Part II of this Regulation - with regard to the installation of an FUPD of an approved type according to Part I of this Regulation, or
for Part III of this Regulation - with regard to its FUP;
- 3.1.8. "Vehicle type" means vehicles which do not essentially differ in such aspects as:
The width of the foremost axle measured at the outermost part of the tyres excluding the bulging of the tyres close to the ground.
The structure, the dimensions, the shape and materials of the front part of the vehicle in so far as they have a bearing on the requirements of the relevant Part of this Regulation.
The approved FUPDs fitted to the vehicle, where the application is pursuant to satisfying Part II of this Regulation.
The maximum mass of the vehicle type.

4. APPLICATION FOR APPROVAL

- 4.1. The application for approval to a Part of this Regulation shall be submitted by the manufacturer of the type (vehicle/FUPD) or his duly accredited representative.
- 4.2. For each type the application shall be accompanied by:
- 4.2.1. Documentation in triplicate giving a description of the technical characteristics of the type (vehicle/FUPD): its dimensions, lines and constituent materials, in so far as required for the purpose of this Regulation.
- 4.2.2. In case of FUPD sample of the type: the sample shall be clearly and indelibly marked on all its main components, relevant to the front underrun, with the applicant's trade name or mark and the type designation;

- 4.2.3. A representative of the type of device or vehicle to be approved shall be submitted for each test to the technical service responsible for conducting the approval tests;
- 4.2.4. For applications pursuant to Parts II or III of this Regulation, a vehicle not comprising all the components proper to the type may be accepted for test provided that they do not adversely affect the front underrun protection.
- 4.2.5. Identification of the positions of the points P₁, P₂ and P₃ as defined in annex 5. For applications pursuant to satisfying Part I of this Regulation these should take into account the requirements of Part II.
- 4.3. Applications pursuant to satisfying Part II of this Regulation shall be accompanied by:
 - 4.3.1. A list of the FUPDs intended to be fitted to the vehicle type;
 - 4.3.2. At the request of the competent authority, the type approval communication form conforming to annex 1 of this Regulation of each FUPD shall also be supplied.
- 4.4. Applications pursuant to satisfying Parts II and III of this Regulation shall be accompanied by information on the vehicle type as defined in paragraph 3.1.8.
- 4.5. The competent authority shall maintain the following administrative procedures according to annex 6 to cover the following:
 - 4.5.1. Verification of the existence of satisfactory arrangements for ensuring effective control of the conformity of production before type approval is granted,
 - 4.5.2. Penalties for non-conformity of production,
 - 4.5.3. Modification or extension of approval of a type,
 - 4.5.4. Production being definitely discontinued.

PART I. APPROVAL OF FRONT UNDERRUN PROTECTIVE DEVICES (FUPDS)

5. APPROVAL OF AN FUPD

- 5.1. If the FUPD submitted for approval pursuant to this Regulation meets the requirements of paragraph 6 below, approval of that type of FUPD shall be granted in accordance with the arrangements contained in annex 4.
- 5.2. Notice of approval, or of extension or of refusal of approval of the type of FUPD pursuant to this Regulation shall be communicated to the Parties to the 1958 Agreement which apply this Regulation, by means of a form conforming to the model in annex 1 to this Regulation.

6. REQUIREMENTS FOR FUPDS

- 6.1. The FUPD shall offer adequate resistance to forces applied parallel to the longitudinal axis of the vehicle and also satisfy certain dimensional

requirements. These shall be demonstrated in accordance with the test procedure and conditions specified in annex 5 to this Regulation.

- 6.2. The section height of the FUPD cross-member shall not be less than 100 mm for category N₂ vehicles and 120 mm for vehicles of category N₃. The lateral extremities of the cross-member shall not bend to the front or have a sharp outer edge; this condition is fulfilled when the lateral extremities of the cross-member are rounded on the outside and have a radius of curvature of not less than 2.5 mm.
- 6.3. The device may be so designed that its position at the front of the vehicle can be varied. In this event, there shall be a guaranteed method of securing it in the service position so that any unintentional change of position is precluded. It shall be possible for the operator to vary the position of the device by applying a force not exceeding 40 daN;
- 6.4. The outermost surfaces of every front guard installation shall be essentially smooth or horizontally corrugated save that domed heads of bolts or rivets may protrude beyond the surface to a distance not exceeding 10 mm.

PART II. APPROVAL OF A VEHICLE WITH REGARD TO THE INSTALLATION OF AN FUPD OF AN APPROVED TYPE

7. APPROVAL OF AN INSTALLATION OF AN APPROVED FUPD

- 7.1. If the vehicle submitted for approval pursuant to this Part of this Regulation is provided with an approved FUPD and meets the requirements of paragraph 8 below, approval of that vehicle type shall be granted in accordance with the arrangements contained in annex 4.
- 7.2. Notice of approval, or of extension or of refusal of approval of the vehicle type pursuant to this Regulation shall be communicated to the Parties to the 1958 Agreement which apply this Regulation, by means of a form conforming to the model in annex 2 to this Regulation.

8. REQUIREMENTS FOR INSTALLATION OF AN APPROVED FUPD

- 8.1. The maximum mass of a vehicle type for which approval is requested shall not exceed the value indicated on the type approval communication form of each approved FUPD intended to be installed on that vehicle.
- 8.2. The vehicle with the FUPD installed shall satisfy certain dimensional requirements specified in annex 5 taking into account the test conditions and information indicated on the communication document contained in annex 1 issued in respect of the FUPD.
- 8.3. The FUPD shall be so fitted to the vehicle that the horizontal distance measured in the rearward direction from the foremost part of the vehicle to the front of the FUPD does not exceed 400 mm diminished by the recorded deformation (annex 1, item 9) measured at any of the points where the test forces have been applied during the type approval of the FUPD in conformity with the provisions of Part I of this Regulation and recorded in the type approval communication form (see figures 1 and 2).

- 8.4. In measuring these distances, any part of the vehicle, which is more than 2 m above the ground, shall be excluded.
- 8.5. The maximum ground clearance with respect to the underside of the FUPD shall be no more than 400 mm, as specified in paragraph 2 of annex 5, between the two points P₁ in the installed condition. Outboard of each point P₁ this height may be greater than 400 mm providing the underside is not above a plane passing through the underside of the FUPD directly below the point P₁ and forming a slope at 15° above the horizontal (see figure 3).
- 8.6. The height above the ground of the points of application of the test forces applied to the FUPD according to Part I of this Regulation and recorded in the type approval communication form (annex 1, item 8) shall not exceed 445 mm as specified in paragraph 2 of annex 5.
- 8.7. The maximum ground clearance with respect to the underside of the FUPD between the two points P₁ shall be no more than 450 mm taking into account their movement during the application of the test load, according to Part I.
- 8.8. The width of the FUPD shall at no point exceed the width of the mudguards covering the wheels of the foremost axle nor shall it be more than 100 mm shorter on either side than the foremost axle measured at the outermost points of the tyres, excluding the bulging of the tyres close to the ground (see figure 1), or 200 mm shorter on either side, measured from the outermost points of the access steps to the driver's cabin.

PART III. APPROVAL OF A VEHICLE WITH REGARD TO ITS FRONT UNDERRUN PROTECTION (FUP)

9. APPROVAL OF A VEHICLE WITH FUP

- 9.1. If the vehicle submitted for approval pursuant to this Regulation is provided with FUP that meets the requirements of paragraph 10 below, approval of that vehicle type shall be granted in accordance with the arrangements contained in annex 4.
- 9.2. Notice of approval, or of extension or of refusal of approval of the vehicle type pursuant to this Regulation shall be communicated to the Parties to the 1958 Agreement which apply this Regulation, by means of a form conforming to the model in annex 3 to this Regulation.

10. REQUIREMENTS FOR A VEHICLE WITH FUP

- 10.1. Any vehicle in one of the categories N₂ or N₃ will be deemed to satisfy the condition set out in paragraph 2 provided that the vehicle is equipped with an FUPD which has not been separately approved to Part I of this Regulation or is so designed and/or equipped at the front that, by virtue of their shape and characteristics, its component parts can be regarded as replacing the front underrun protective device. Components whose combined function satisfies the following requirements are considered to form a front underrun protective device.
- 10.2. The FUP shall offer adequate resistance to forces applied parallel to the longitudinal axis of the vehicle. The FUP shall also satisfy certain dimensional

- requirements. These shall be demonstrated in accordance with the test procedure and conditions specified in annex 5 to this Regulation.
- 10.3. For application pursuant to Part III, the section height of the FUPD cross-member (not separately approved to Part I) shall not be less than 100 mm for category N₂ vehicles and 120 mm for vehicles of category N₃.
- 10.4. The device may be so designed that its position at the front of the vehicle can be varied. In this event, there shall be a guaranteed method of securing it in the service position so that any unintentional change of position is precluded. It shall be possible for the operator to vary the position of the device by applying a force not exceeding 40 daN;
- 10.5. The FUP shall have sufficient strength that the horizontal distance measured in the rearward direction between the foremost part of the vehicle after the application of the test forces (specified in this annex) and the test ram contact surface on the vehicle does not exceed 400 mm.
- 10.6. In measuring these distances, any part of the vehicle, which is more than 2 m above the ground, shall be excluded.
- 10.7. The maximum ground clearance with respect to the underside of the FUP shall be no more than 400 mm, as specified in paragraph 2 of annex 5, between the two points P₁. Outboard of each point P₁ this height may be greater than 400 mm providing the underside is not above a plane passing through the underside of the FUP directly below the point P₁ and forming a slope at 15° above the horizontal (see figure 3).
- 10.8. The maximum ground clearance with respect to the underside of the FUP between the two points P₁ shall be no more than 450 mm taking into account their movement during the application of the test load.
- 10.9. The width of the FUP shall at no point exceed the width of the mudguards covering the wheels of the foremost axle nor shall it be more than 100 mm shorter on either side than the foremost axle measured at the outermost points of the tyres, excluding the bulging of the tyres close to the ground (see figure 1), or 200 mm shorter on either side, measured from the outermost points of the access steps to the driver's cabin.

FIGURE 1

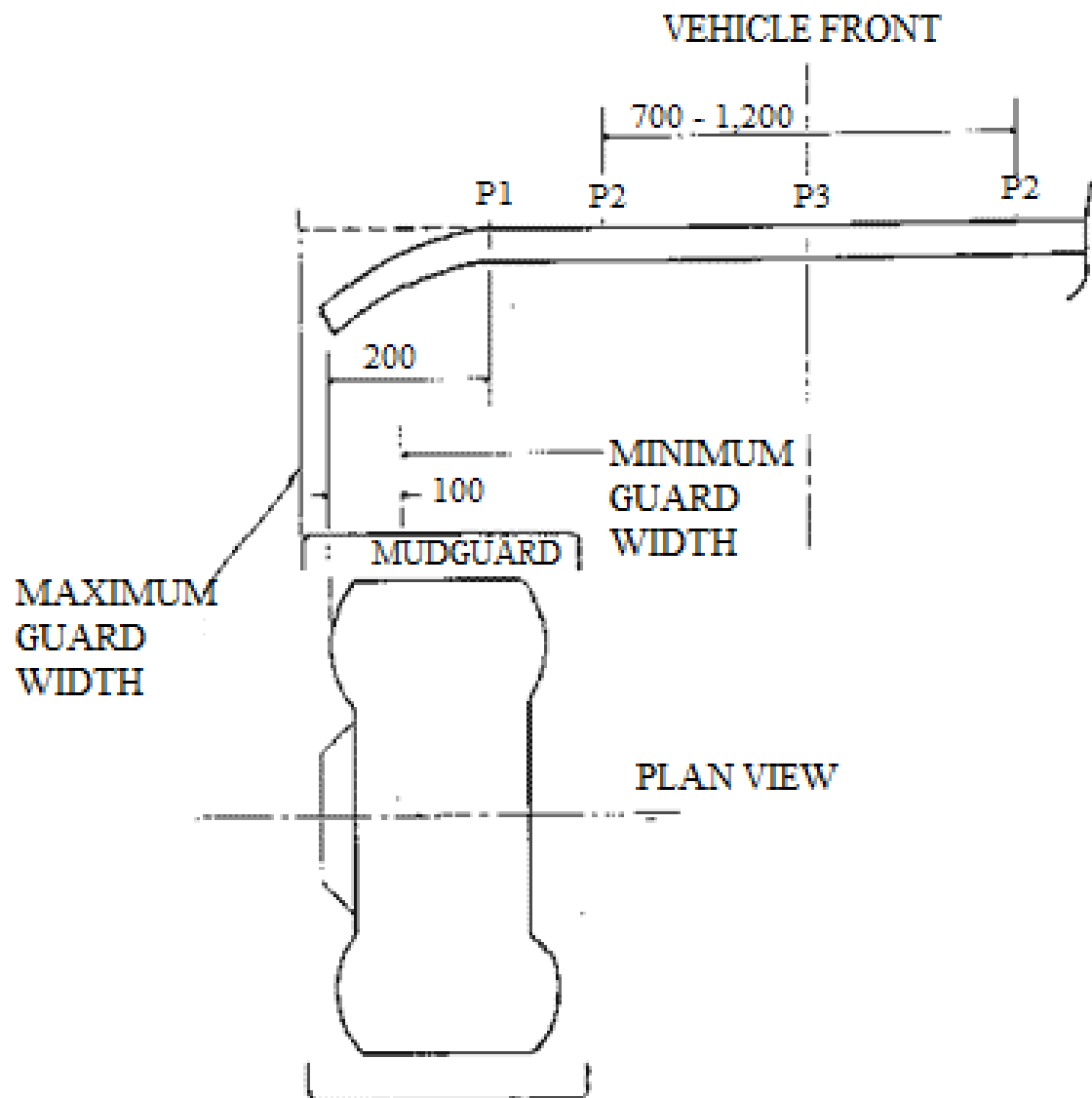

FUP NORMALLY CONSISTS OF A CROSS-MEMBER AND LINKS TO THE CHASSIS OR OTHER STRUCTURAL MEMBERS

Note: The shape of FUPD is only an example.

FIGURE 2

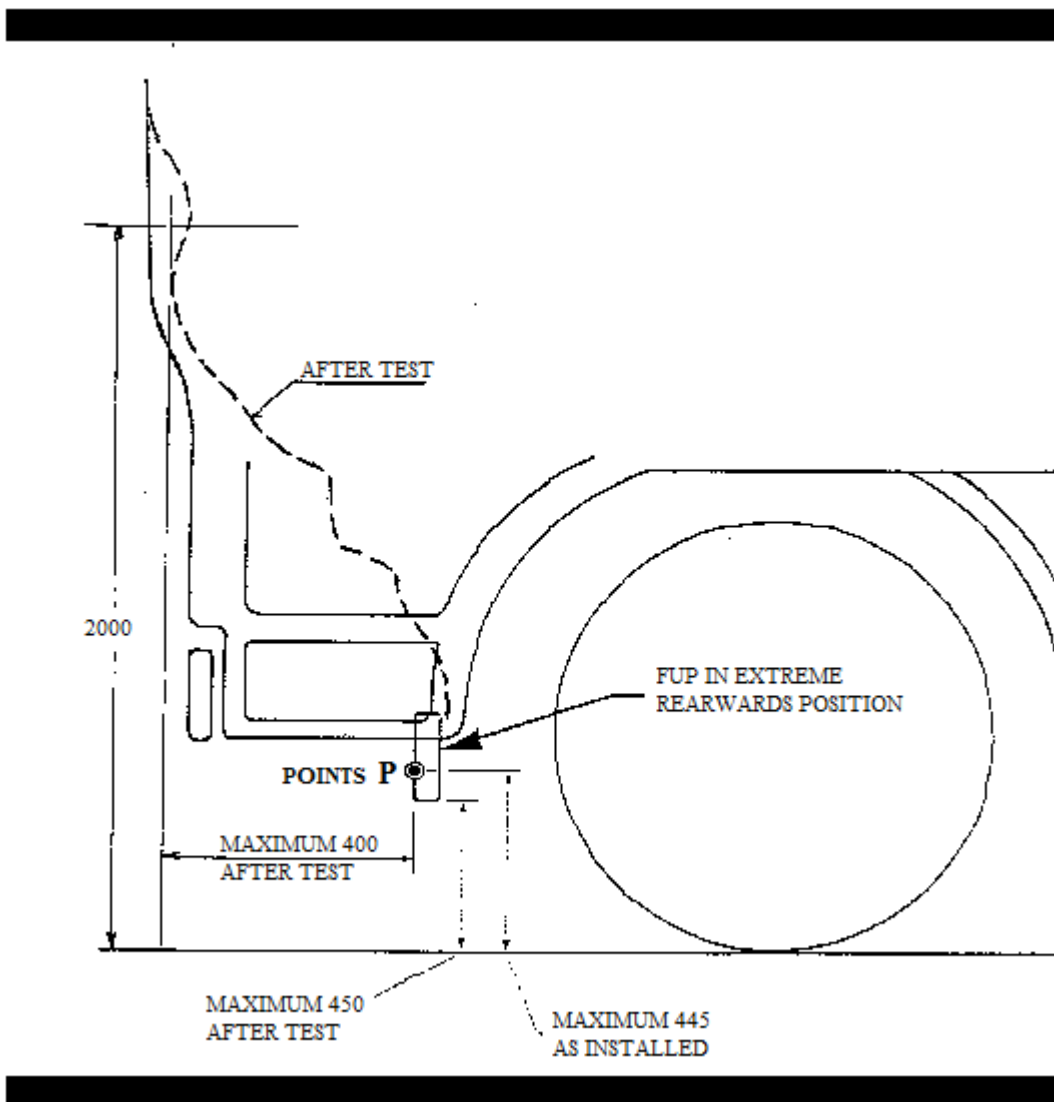
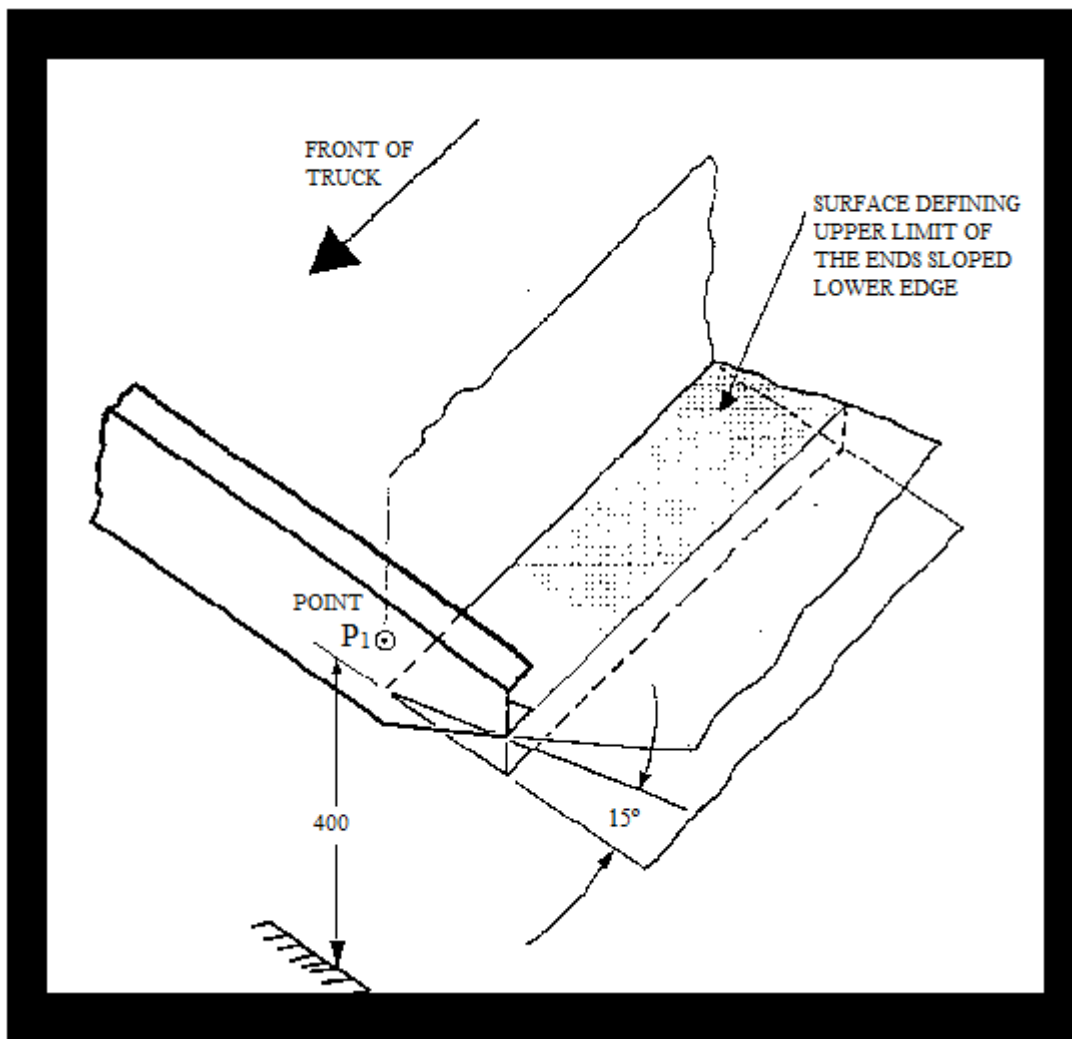

FIGURE 3



ANNEX 1

COMMUNICATION

(Maximum format: A4 (210 x 297 mm))

issued by: Name of administration:



concerning:² APPROVAL GRANTED
APPROVAL EXTENDED
APPROVAL REFUSED
APPROVAL WITHDRAWN
PRODUCTION DEFINITELY DISCONTINUED

of a type of front underrun protection device (FUPD) pursuant to Regulation No. 93 (Part I)

Approval No.:

Extension No.:

1. Trade name or mark of technical unit
2. If necessary the type of vehicle(s) and category to which it is intended
3. Maximum mass of vehicle(s) to which FUPD is to be installed
4. Name and address of manufacturer
5. Name and address of manufacturer's authorized representative (if any)
6. Characteristics of the technical unit
7. Restrictions on use and mounting specifications (if any)
8. Position on the device of the points of application of the test forces
9. Maximum horizontal and vertical deflection during and after the application of the test forces of any test point
10. Date on which the device was submitted for approval tests
11. Technical service responsible for carrying out the approval tests on devices
12. Date of test report issued by the technical service
13. Number of test report issued by the technical service
14. Approval granted/refused/extended/withdrawn²
15. Reason(s) for the extension of the approval applicable
16. Position of the approval mark
17. Place
18. Date
19. Signature
Name
20. The list of documents filed with the administration which has granted approval, and is available, is annexed to this communication.
21. Remarks (if any)

¹ Distinguishing number of the country which has granted/extended/refused/withdrawn approval (see approval provisions in the Regulation).

² Strike out what does not apply.

ANNEX 2

(Maximum format: A4 (210 x 297 mm))

COMMUNICATION

issued by: Name of administration:



concerning:² APPROVAL GRANTED
APPROVAL EXTENDED
APPROVAL REFUSED
APPROVAL WITHDRAWN
PRODUCTION DEFINITELY DISCONTINUED

of a vehicle type with regard to the installation of a front underrun protection device (FUPD)
of an approved type pursuant to Regulation No. 93 (Part II)

Approval No.:

Extension No.:

1. Trade name or mark of the vehicle
2. Type and category of vehicle(s)
3. Maximum mass of vehicle(s)
4. Name and address of manufacturer
5. Name and address of manufacturer's authorized representative (if any)
6. Brief description of the vehicle type as regards its dimensions and lines
7. Trade name or mark of the FUPD(s) and its/their approval number(s)
8. Date on which vehicle was submitted for approval tests
9. Technical service responsible for carrying out the approval tests on vehicles:
10. Date of test report issued by the technical service:
11. Number of test report issued by the technical service:
12. Approval granted/refused/extended/withdrawn²
13. Reason(s) for the extension of the approval applicable:
14. Position of approval mark on the vehicle
15. Place:
16. Date:
17. Signature:
Name:
18. Annexed is a list of documents making up the approval file, deposited with the competent authority, which granted approval; a copy can be obtained on request.
19. Remarks (if any):

¹ Distinguishing number of the country which has granted/extended/refused/withdrawn approval (see approval provisions in the Regulation).

² Strike out what does not apply.

ANNEX 3

(Maximum format: A4 (210 x 297 mm))

COMMUNICATION

issued by: Name of administration



concerning:² APPROVAL GRANTED
APPROVAL EXTENDED
APPROVAL REFUSED
APPROVAL WITHDRAWN
PRODUCTION DEFINITELY DISCONTINUED

of a vehicle with regard to its front underrun protection (FUP) pursuant to Regulation No. 93 (Part III)

Approval No.:

Extension No.:

1. Trade name or mark of the vehicle
2. Type and category of vehicle(s)
3. Maximum mass of vehicle(s)
4. Name and address of manufacturer
5. If applicable, name and address of manufacturer's representative
6. Characteristics of the parts providing frontal protection
7. Date on which the vehicle was submitted for approval tests
8. Position on the FUP of the points of application of the test forces
9. Maximum vertical and horizontal deflection during and after the application of the test forces of any test point
10. Technical service responsible for carrying out the approval tests on vehicles
11. Date of test report issued by the technical service
12. Number of test report issued by the technical service
13. Approval granted/refused/extended/withdrawn²
14. Reason(s) for the extension of the approval applicable
15. Position of approval mark on the vehicle
16. Place
17. Date
18. Signature
Name
19. Annexed is a list of documents making up the approval file, deposited with the competent authority, which granted approval; a copy can be obtained on request.
20. Remarks (if any)

¹ Distinguishing number of the country which has granted/extended/refused/withdrawn approval (see approval provisions in the Regulation).

² Strike out what does not apply.

ANNEX 4

ARRANGEMENTS OF APPROVAL MARKS

1. APPROVAL NUMBER
 - 1.1. An approval number shall be assigned to each type approved. Its first two digits (at present 00) shall indicate the series of amendments incorporating the most recent major technical amendments made to the Regulation at the time of issue of the approval. The same Contracting Party shall not assign the same number to another type.
 - 1.2. Notice of approval, or of extension or of refusal of approval of a type pursuant to this Regulation shall be communicated to the Parties to the 1958 Agreement which apply this Regulation, by means of a form conforming to one of the models in annexes 1, 2 or 3 to this Regulation.
 - 1.3. There shall be affixed, conspicuously and in the case of a technical unit in a position where in the installed condition it is readily accessible and specified on the approval form, to every one of series conforming to a type approved under this Regulation an international approval mark consisting of:
 - 1.3.1. A circle surrounding the letter "E" followed by the distinguishing number of the country which has granted approval;¹
 - 1.3.2. The number of this Regulation, followed by the letter "R", a dash and the approval number to the right of the circle prescribed in paragraph 1.3.1.
 - 1.3.3. An additional symbol separated from the number of this Regulation by a vertical line and consisting of the Roman numeral(s) for the Part (I, II or III) of the Regulation pursuant to which the device or the vehicle has been approved.
 - 1.4. If the vehicle conforms to a vehicle type approved, under one or more other Regulations annexed to the Agreement, in the country, which has granted approval under this Regulation, the symbol prescribed in paragraph 1.3.1. of this annex need not be repeated; in such a case the Regulation and approval numbers and the additional symbols of all the Regulations under which approval has been granted in the country which has granted approval under this Regulation shall be placed in vertical columns to the right of the symbol prescribed in paragraph 1.3.1. of this annex.
 - 1.5. The approval mark shall be clearly legible and be indelible.

¹ 1 for Germany, 2 for France, 3 for Italy, 4 for the Netherlands, 5 for Sweden, 6 for Belgium, 7 for Hungary, 8 for the Czech Republic, 9 for Spain, 10 for Yugoslavia, 11 for the United Kingdom, 12 for Austria, 13 for Luxembourg, 14 for Switzerland, 15 (vacant), 16 for Norway, 17 for Finland, 18 for Denmark, 19 for Romania, 20 for Poland, 21 for Portugal, 22 for the Russian Federation, 23 for Greece, 24, 25 (vacant), 26 for Slovenia and 27 for Slovakia. Subsequent numbers shall be assigned to other countries in the chronological order in which they ratify or accede to the Agreement concerning the Recognition of Approval for Motor Vehicle Equipment and Parts, and the numbers thus assigned shall be communicated by the Secretary-General of the United Nations to the Contracting Parties to the Agreement.

2. ARRANGEMENTS OF APPROVAL MARKS

2.1. Model A

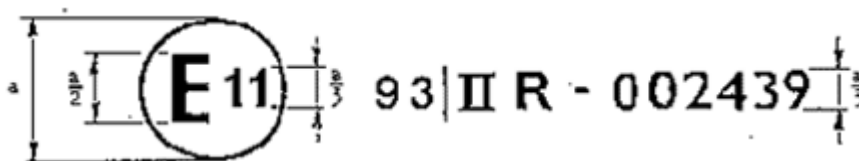

2.1.1. The above approval mark affixed to a vehicle shows that the vehicle type concerned has, with regard to the front underrun protection in the event of a collision, been approved in the United Kingdom (E11) pursuant to Regulation No. 93, Part II (installation of a front underrun protection device (FUPD) of an approved type) under approval number 002439. The first two digits of the approval number indicate that the approval was granted in accordance with the requirements of Regulation No. 93, Part II in its original form.

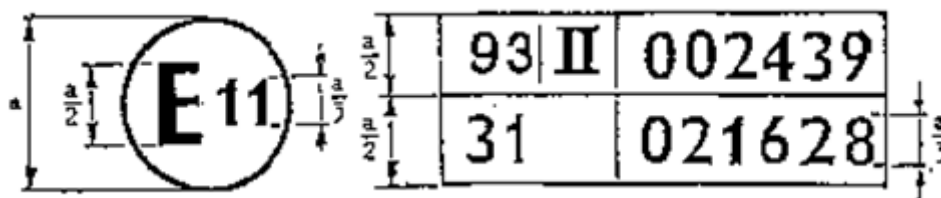

2.2. Model B

2.2.1. The above approval mark affixed to a vehicle shows that the vehicle type concerned has been approved in the United Kingdom (E 11) pursuant to Regulation No. 93, Part II and Regulation No. 31.¹ The approval numbers indicate that, at the dates when the respective approvals were given, Regulation No. 93 was in its original form and Regulation No. 31 included the 02 series of amendments.

¹ The latter number is given as an example only.

ANNEX 5

TEST CONDITIONS AND PROCEDURES

1. TEST CONDITIONS FOR FUPDS
 - 1.1. At the request of the manufacturer the test may be conducted either:
 - 1.1.1. On a vehicle of the type for which FUPD is intended; in that case the conditions set out in paragraph 2 shall be observed; or
 - 1.1.2. On a part of the chassis of the vehicle type for which the FUPD is intended; this part shall be representative of the vehicle type(s) in question; or
 - 1.1.3. On a rigid test bench.
 - 1.2. In the case of paragraphs 1.1.2. and 1.1.3. above the parts used to connect the FUPD to part of the vehicle chassis or to the rigid test bench shall be equivalent to those which are used to secure the FUPD when it is installed on the vehicle.
 - 1.3. At the request of the manufacturer and with the consent of the technical service the test procedure described in paragraph 3 below may be simulated by calculation or another such method provided that its equivalence is demonstrated.
2. TEST CONDITIONS FOR VEHICLES
 - 2.1. The vehicle may, if necessary to achieve the test forces required in paragraph 3.1. below, be restrained by any method, this method to be specified by the vehicle manufacturer.
 - 2.2. Dimensions shall be taken as if the vehicle were in the following condition:
 - 2.2.1. The vehicle was unladen.
 - 2.2.2. The vehicle was at rest on a level, flat, rigid and smooth surface.
 - 2.2.3. The front wheels were in the straight-ahead position.
 - 2.2.4. The tyres were inflated to the pressure recommended by the vehicle manufacturer.
 - 2.2.5. Vehicles equipped with hydropneumatic, hydraulic or pneumatic suspension or a device for automatic levelling according to load were in their normal running condition specified by the manufacturer.
3. TEST PROCEDURE
 - 3.1. Points P₁ are located up to 200 mm from the longitudinal planes tangential to the outermost points of the tyres on the front axle, excluding the bulging of the tyres close to the ground; points P₂ are symmetrical to the median longitudinal plane of the vehicle at a distance from each other of 700 to 1,200 mm inclusive. The exact positions shall be specified by the manufacturer.

- 3.2. The height above the ground of points P₁ and P₂ shall be defined by the vehicle manufacturer within the lines that bound the front face of the device. The height shall not, however, exceed 445 mm when the vehicle is unladen. P₃ is in the vertical longitudinal median plane of the vehicle (see figure 1 of the Regulation).
- 3.3. The test forces set out below shall be applied to each of the test points in separate tests on the same vehicle or device or, if requested by the manufacturer/agent, on different vehicles or device samples.
- 3.3.1. If the structure and components of the vehicle relevant to the front underrun protection are located substantially symmetrical to its longitudinal median plane the tests at points P₁ and P₂ shall be carried out only on one side.
- 3.3.2. When tested the forces shall be applied as rapidly as possible and the device or vehicle shall withstand the forces in the following paragraphs for at least 0.2 seconds.
- 3.3.3. A horizontal force equal to 50% of the maximum weight of the vehicle or intended vehicle type(s) but not exceeding 80 x 10³ N shall be applied successively to both points P₁;
- 3.3.4. A horizontal force equal to 100% of the maximum weight of the vehicle or intended vehicle type(s) but not exceeding 160 x 10³ N shall be applied successively to both points P₂. If the device is discontinuous and is reduced in cross-section area between the two points P₂, then the tests shall continue with the application of a horizontal force applied to the point P₃ the same as that to the points P₁;
- 3.4. The maximum horizontal and vertical displacements of each test point during the application of the above forces shall be recorded and the highest recorded on the communication document.
- 3.5. Whenever a practical test is performed to verify compliance with the above-mentioned requirements, the following conditions shall be fulfilled:
- 3.5.1. For application pursuant to Part III, an FUPD (not separately approved to Part I) shall be connected to the chassis side members of the vehicle or to whatever replaces them or a structure with demonstrated equivalent performance capabilities.
- 3.5.2. The specified forces shall be applied by rams which are suitably articulated (e.g. by means of universal joints) and shall be parallel to the median longitudinal plane of the vehicle via a surface not more than 250 mm in height (the exact height and width shall be indicated by the manufacturer) and not more than 400 mm wide, with a radius of curvature of 5 ± 1 mm at the vertical edges; the centre of the surface is placed successively at points P₁, P₂ and P₃.

ANNEX 6

CONFORMITY OF PRODUCTION AND OTHER ADMINISTRATIVE PROCEDURES

1. CONFORMITY OF PRODUCTION
 - 1.1. FUPDs and vehicles approved to this Regulation shall be so manufactured as to conform to the type approval by meeting the requirements set forth in this Regulation.
 - 1.2. In order to verify that the requirements of paragraph 1.1. above are met, suitable controls of the production shall be carried out.
 - 1.3. The holder of the approval shall in particular:
 - 1.3.1. ensure existence of procedures for the effective control of the quality of the vehicle or the device;
 - 1.3.2. have access to the testing equipment necessary for checking the conformity to each approved type;
 - 1.3.3. record data of test results and annexed documents which shall remain available for a period to be determined in accordance with the administrative service;
 - 1.3.4. analyse the results of each type of test, in order to verify and ensure the stability of the vehicle or the device characteristics making allowance for variations of an industrial production;
 - 1.3.5. ensure that for each type of vehicle or device sufficient checks and tests are carried out regarding the dimensions, materials and performance of the components, which fulfil the function of the FUP and of those for the installation on the vehicle;
 - 1.3.6. ensure that any set of samples or test pieces giving evidence of non-conformity with the type of test considered shall give rise to another sampling and another test. All the necessary steps shall be taken to re-establish the conformity of the corresponding production.
 - 1.4. The competent authority, which has granted type-approval, may at any time verify the conformity control methods applicable to each production unit.
 - 1.4.1. In every inspection, the test books and production survey records shall be presented to the visiting inspector.
 - 1.4.2. The inspector may take samples at random which will be tested in the manufacturer's laboratory. The minimum number of samples may be determined according to the results of the manufacturer's own verification.
 - 1.4.3. When the quality level appears unsatisfactory or when it seems necessary to verify the validity of the tests carried out in application of paragraph 1.4.2. above the inspector may select samples to be sent to the technical service which has conducted the type approval tests.
 - 1.4.4. The competent authority may carry out any test prescribed in this Regulation.

1.4.5. The normal frequency of inspections authorized by the competent authority shall be one per two years. In the case when negative results are recorded during one of these visits, the competent authority shall ensure that all necessary steps are taken to re-establish the conformity of production as rapidly as possible.

2. PENALTIES FOR NON-CONFORMITY OF PRODUCTION

2.1. The approval granted in respect of a type of FUPD or vehicle pursuant to this Regulation may be withdrawn if the requirements set forth above are not met or if the protective device has failed to pass the test prescribed in this Regulation.

2.2. If a Contracting Party to the Agreement applying this Regulation withdraws an approval it has previously granted, it shall forthwith so notify the other Contracting Parties applying this Regulation, by means of a communication form conforming to the model in annexes 1, 2 or 3 to this Regulation.

3. MODIFICATION AND EXTENSION OF APPROVAL

3.1. Every modification of a type of FUPD or vehicle shall be notified to the administrative department, which approved the type. The department may then either:

3.1.1. Consider that the modifications made are unlikely to have an appreciable adverse effect and that in any case the FUPD or vehicle still complies with the requirements; or

3.1.2. Require a further test report from the technical service responsible for conducting the tests.

3.2. Confirmation or refusal of approval, specifying the alterations shall be communicated by means of a form conforming to the model in annexes 1, 2 or 3 to this Regulation to the Parties to the Agreement applying this Regulation.

3.3. The competent authority issuing the extension of approval shall assign a series number to such an extension and inform thereof the other Parties to the 1958 Agreement applying this Regulation by means of a communication form conforming to the model in annexes 1, 2 or 3 to this Regulation.

4. PRODUCTION DEFINITELY DISCONTINUED

If the holder of the approval completely ceases to manufacture a type of FUPD or vehicle FUP approved in accordance with this Regulation, he shall so inform the authority, which granted the approval. Upon receiving the relevant communication that authority shall inform thereof the other Parties to the 1958 Agreement applying this Regulation by means of a communication form conforming to the model in annexes 1, 2 or 3 to this Regulation.

5. NAMES AND ADDRESSES OF TECHNICAL SERVICES RESPONSIBLE FOR CONDUCTING APPROVAL TESTS, AND OF ADMINISTRATIVE DEPARTMENTS

The Contracting Parties to the 1958 Agreement applying this Regulation shall communicate to the United Nations Secretariat the names and addresses of the

technical services responsible for conducting approval tests and of the administrative departments which grant approval and to which forms certifying approval or extension or refusal or withdrawal of approval, or production definitely discontinued, issued in other countries, are to be sent.”

[2] Delete Appendix B and replace with:

“APPENDIX B

CLASSIFICATION AND DEFINITION OF POWER-DRIVEN VEHICLES AND TRAILERS

Refer Clause 3.4.1

The following is a modified extract from the Economic Commission for Europe Consolidated Resolution on the Construction of Vehicles (R.E.3, annex 7) incorporating Amendment 2 to Revision 1.

1. NOT USED
2. NOT USED
3. CATEGORY N - POWER-DRIVEN VEHICLES HAVING AT LEAST FOUR WHEELS AND USED FOR THE CARRIAGE OF GOODS
 - 3.1. NOT USED
 - 3.2. Category N₂:
Vehicles used for the carriage of goods and having a maximum mass exceeding 3.5 tonnes but not exceeding 12 tonnes.
 - 3.3. Category N₃:
Vehicles used for the carriage of goods and having a maximum mass exceeding 12 tonnes.
 - 3.4. Remarks
 - 3.4.1. In the case of a towing vehicle designed to be coupled to a semitrailer (tractor for semitrailer), the mass to be considered for classifying the vehicle is the mass of the tractor vehicle in running trim, increased by the mass corresponding to the maximum static vertical load transferred to the tractor vehicle by the semitrailer and, where applicable, by the maximum mass of the tractor vehicle's own load.
 - 3.4.2. The equipment and installations carried on certain special purpose vehicles (crane vehicles, workshop vehicles, publicity vehicles, etc.) are regarded as being equivalent to goods.
4. NOT USED
5. NOT USED
6. NOT USED
7. CATEGORY G - OFF-ROAD VEHICLES
 - 7.1. Definition.

Off-road vehicles are considered to be the vehicles of categories M and N satisfying the requirements of this paragraph, checked under the conditions indicated in paragraphs 7.2. and 7.3.

7.1.1. NOT USED

7.1.2. Vehicles in category N₁ with a maximum mass exceeding 2 tonnes or in category N₂, M₂ or M₃ with a maximum mass not exceeding 12 tonnes are considered to be off-road vehicles either if all their wheels are designed to be driven simultaneously, including vehicles where the drive to one axle can be disengaged, or if the following three requirements are satisfied:

at least one front axle and at least one rear axle are designed to be driven simultaneously, including vehicles where the drive to one axle can be disengaged;

there is at least one differential locking mechanism or at least one mechanism having a similar effect;

they can climb a 25 per cent gradient calculated for a solo vehicle.

7.1.3. Vehicles in category M₃ with a maximum mass exceeding 12 tonnes or in category N₃ are considered to be off-road either if the wheels are designed to be driven simultaneously, including vehicles where the drive to one axle can be disengaged, or if the following requirements are satisfied:

at least half the wheels are driven;

there is at least one differential locking mechanism or at least one mechanism having a similar effect;

they can climb a 25 per cent gradient calculated for a solo vehicle;

at least four of the following six requirements are satisfied:

the approach angle must be at least 25°;

the departure angle must be at least 25°;

the ramp angle must be at least 25°;

the ground clearance under the front axle must be at least 250 mm;

the ground clearance between the axles must be at least 300 mm;

the ground clearance under the rear axle must be at least 250 mm.

7.2. Load and checking conditions.

7.2.1. NOT USED

7.2.2. Power-driven vehicles other than those referred to in paragraph 7.2.1. must be loaded to the technically permissible maximum mass stated by the manufacturer.

7.2.3. The ability to climb the required gradients (25 per cent and 30 per cent) is verified by simple calculation. In exceptional cases, however, the technical services may ask for a vehicle of the type concerned to be submitted to it for an actual test.

7.2.4. When measuring front and rear incidence angles and ramp angles, no account is taken of underrun protective devices.

7.3. Definitions and sketches of front and rear incidence angles, ramp angle and ground clearance.

7.3.1. 'Approach angle' - see Standard ISO 612:1978, term No. 6.10.



7.3.2. 'Departure angle' - see Standard ISO 612:1978, term No. 6.11.

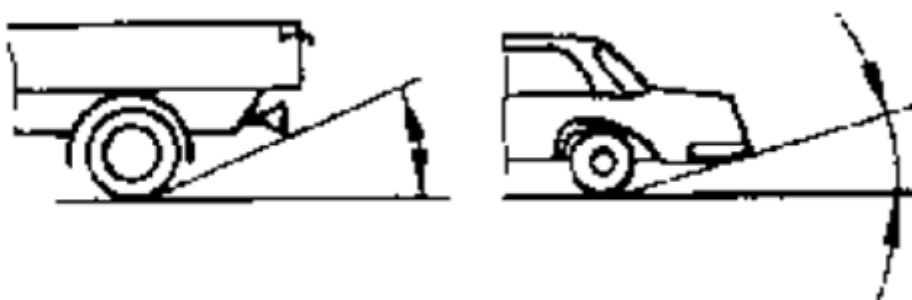

7.3.3. 'Ramp angle' - see Standard ISO 612:1978, term No. 6.9.

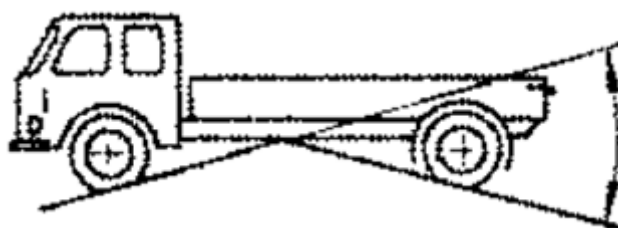

7.3.4. "Ground clearance between the axles" means the shortest distance between the ground plane and the lowest fixed point of the vehicle. Multi-axle bogies are considered to be a single axle.

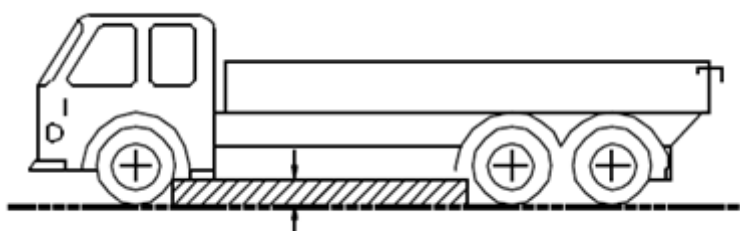

- 7.3.5. “Ground clearance beneath one axle” means the distance beneath the highest point of the arc of a circle passing through the centre of the tyre footprint of the wheels on one axle (the inner wheels in the case of twin tyres) and touching the lowest fixed point of the vehicle between the wheels. No rigid part of the vehicle may project into the shaded area of the diagram. Where appropriate, the ground clearance of several axles is indicated in accordance with their arrangement, for example 280/250/250.

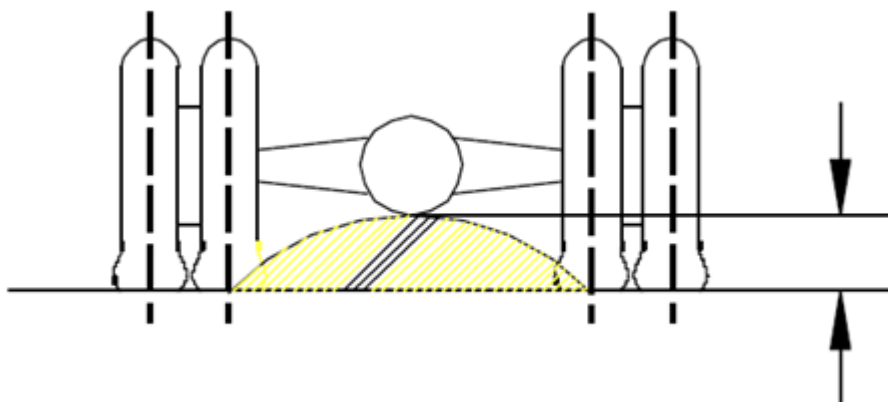

- 7.4. Combined designation.
Symbols M and N may be combined with symbol G.
For example, a vehicle of category N_1 which is suited for off-road use may be designated as N_1G .”