



## **Vehicle Standard (Australian Design Rule 93/00 – Forward Field of View) 2018**

I, ANDREW BROAD, Assistant Minister to the Deputy Prime Minister, determine this vehicle standard under section 7 of the *Motor Vehicle Standards Act 1989*.

Dated 25 October 2018

[SIGNED]

Andrew Broad

Assistant Minister to the Deputy Prime Minister

---

## CONTENTS

1.	LEGISLATIVE PROVISIONS.....	3
2.	FUNCTION.....	3
3.	APPLICABILITY .....	3
4.	DEFINITIONS .....	5
5.	REQUIREMENTS .....	5
6.	EXEMPTIONS AND ALTERNATIVE PROCEDURES .....	5
7.	ALTERNATIVE STANDARDS .....	6
	APPENDIX A .....	7

## **1. LEGISLATIVE PROVISIONS**

- 1.1. Name of Standard
  - 1.1.1. This Standard is the Vehicle Standard (Australian Design Rule 93/00 – Forward Field of View) 2018.
  - 1.1.2. This Standard may also be cited as Australian Design Rule 93/00 – Forward Field of View.
- 1.2. Commencement
  - 1.2.1. This Standard commences on the day after it is registered.

## **2. FUNCTION**

- 2.1. The function of this vehicle standard is to ensure the driver has an adequate field of view to either side and in all directions in front of the vehicle.

## **3. APPLICABILITY**

- 3.1. This vehicle standard applies to category L, M and N vehicles from the dates set out in in clauses 3.1.1 to 3.1.2 and the table under clause 3.3 below.
  - 3.1.1. 1 July 2019 for all new model vehicles.
  - 3.1.2. There is no mandatory application date for all other vehicles. They may comply with this vehicle standard, or continue to comply with the Australian Design Rule 42/04 – General Safety Requirements.
- 3.2. For the purposes of clause 3.1.1, a “new model” is a vehicle model first produced with a ‘*Date of manufacture*’ on or after the agreed date in that clause.

## 3.3. Applicability Table

Vehicle Category	ADR Category Code	UN Category Code*	Manufactured on or After**	Acceptable Prior Rules
Moped 2 wheels	LA	L1	1 July 2019	See clause 3.1.2
Moped 3 wheels	LB	L2	1 July 2019	See clause 3.1.2
Motor cycle	LC	L3	1 July 2019	See clause 3.1.2
Motor cycle and sidecar	LD	L4	1 July 2019	See clause 3.1.2
Motor tricycle	LE	L5		
	LEM		1 July 2019	See clause 3.1.2
	LEP		1 July 2019	See clause 3.1.2
	LEG		1 July 2019	See clause 3.1.2
Passenger car	MA	M1	1 July 2019	See clause 3.1.2
Forward-control passenger vehicle	MB	M1	1 July 2019	See clause 3.1.2
Off-road passenger vehicle	MC	M1	1 July 2019	See clause 3.1.2
Light omnibus	MD	M2		
up to 3.5 tonnes 'GVM' and up to 12 seats	MD1		1 July 2019	See clause 3.1.2
up to 3.5 tonnes 'GVM' and more than 12 seats	MD2		1 July 2019	See clause 3.1.2
over 3.5 tonnes and up to 4.5 tonnes 'GVM'	MD3		1 July 2019	See clause 3.1.2
over 4.5 tonnes and up to 5 tonnes 'GVM'	MD4		1 July 2019	See clause 3.1.2
Heavy omnibus	ME	M3	1 July 2019	See clause 3.1.2
Light goods vehicle	NA	N1	1 July 2019	See clause 3.1.2
Medium goods vehicle	NB	N2		
over 3.5 tonnes up to 4.5 tonnes 'GVM'	NB1		1 July 2019	See clause 3.1.2
over 4.5 tonnes up to 12 tonnes 'GVM'	NB2		1 July 2019	See clause 3.1.2
Heavy goods vehicle	NC	N3	1 July 2019	See clause 3.1.2
Very light trailer	TA	O1	N/A	
Light trailer	TB	O2	N/A	
Medium trailer	TC	O3	N/A	
Heavy trailer	TD	O4	N/A	

\* The category code may also be in the format L<sub>1</sub>, L<sub>2</sub>, L<sub>3</sub> etc

\*\* See clause 3.1

#### **4. DEFINITIONS**

- 4.1. For vehicle categories, definitions and meanings used in this standard, refer to:
- 4.1.1. Vehicle Standard (Australian Design Rule Definitions and Vehicle Categories) 2005; and
- 4.1.2. Definitions in Appendix A of this standard or the alternative standards at clause 7.

#### **5. REQUIREMENTS**

- 5.1. A vehicle must not be so constructed or equipped, nor must anything be affixed thereto in such a manner as to prevent the driver from having an adequate view of traffic on either side of the vehicle and in all directions in front of the vehicle, to enable the vehicle to be driven with safety.
- 5.2. The '*Seating Reference Point*' of a passenger seating position must not be any more than 100 mm in front of the '*Seating Reference Point*' of the driver's seating position.
- 5.3. A vehicle must not include any seating for a passenger at the right-hand side of the driver.
- 5.4. Category MA, MB and MC vehicles, which meet the requirements of Appendix A as varied by Section 6 Exemptions and Alternative Procedures, will be deemed to comply with this rule.

#### **6. EXEMPTIONS AND ALTERNATIVE PROCEDURES**

- 6.1. Compliance with the following parts, sections and annexes of Appendix A is not required for the purposes of clause 5.4 of this standard:
- |            |  |
|------------|--|
| Section 3  | Application for approval   |
| Section 4  | Approval   |
| Section 7  | Modification of a vehicle type and extension of approval   |
| Section 8  | Conformity of production   |
| Section 9  | Penalties for non-conformity of production   |
| Section 10 | Production definitively discontinued   |
| Section 11 | Names and addresses of Technical Services conducting approval tests and of Type Approval Authorities |
| Section 12 | Transitional provisions  |
- Annexes**
- |         |                               |
|---------|-------------------------------|
| Annex 1 | Communication                 |
| Annex 2 | Arrangement of approval marks |

**7. ALTERNATIVE STANDARDS**

- 7.1. For category MA, MB and MC vehicles, the technical requirements of the United Nations Regulation No. 125 – UNIFORM PROVISIONS CONCERNING THE APPROVAL OF MOTOR VEHICLES WITH REGARD TO THE FORWARD FIELD OF VISION OF THE MOTOR VEHICLE DRIVER, incorporating from the 00 series of amendments up to and including the 01 series of amendments, are deemed to be equivalent to the technical requirements of this standard.

---

## APPENDIX A

### Agreement

#### **Concerning the Adoption of Harmonized Technical United Nations Regulations for Wheeled Vehicles, Equipment and Parts which can be Fitted and/or be Used on Wheeled Vehicles and the Conditions for Reciprocal Recognition of Approvals Granted on the Basis of these United Nations Regulations\***

(Revision 3, including the amendments which entered into force on 14 September 2017)

---

### **Addendum 124: UN Regulation No. 125**

#### **Incorporating by the Department of Infrastructure, Regional Development and Cities, all valid text up to:**

01 series of amendments – Date of entry into force: 15 July 2013

Supplement 1 to the 01 series of amendments – Date of entry into force: 8 October 2016

#### **Uniform provisions concerning the approval of motor vehicles with regard to the forward field of vision of the motor vehicle driver**

---

\* Former titles of the Agreement:  
Agreement concerning the Adoption of Uniform Conditions of Approval and Reciprocal Recognition of Approval for Motor Vehicle Equipment and Parts, done at Geneva on 20 March 1958 (original version);  
Agreement concerning the Adoption of Uniform Technical Prescriptions for Wheeled Vehicles, Equipment and Parts which can be Fitted and/or be Used on Wheeled Vehicles and the Conditions for Reciprocal Recognition of Approvals Granted on the Basis of these Prescriptions, done at Geneva on 5 October 1995 (Revision 2).

## UN Regulation No. 125

### Uniform provisions concerning the approval of motor vehicles with regard to the forward field of vision of the motor vehicle driver

#### Contents

	<i>Page</i>
Regulation	
1. Scope .....	9
2. Definitions for the purpose of this Regulation .....	9
3. Application for approval .....	11
4. Approval .....	11
5. Specifications .....	12
6. Test procedure .....	17
7. Modification of vehicle type and extension of approval .....	18
8. Conformity of production .....	18
9. Penalties for non-conformity of production .....	18
10. Production definitively discontinued .....	19
11. Names and addresses of Technical Services responsible for conducting approval tests, and of Type Approval Authorities .....	19
12. Transitional provisions .....	19
Annexes	
1 Communication .....	20
2 Arrangements of approval marks .....	22
3 Procedure for determining the "H" point and the actual torso angle for seating positions in motor vehicles .....	23
Appendix 1: Description of the three-dimensional "H" point machine (3-D H machine).....	23
Appendix 2: Three-dimensional reference system .....	23
Appendix 3: Reference data concerning seating positions .....	23
4 Method for determining the dimensional relationships between the vehicle's primary reference marks and the three-dimensional reference grid .....	24
Appendix .....	25



## 1. Scope

- 1.1. This Regulation applies to the 180° forward field of vision of drivers of category M<sub>1</sub> vehicles<sup>1</sup>.
- 1.2. Its purpose is to ensure an adequate field of vision when the windscreen and other glazed surfaces are dry and clean.
- 1.3. The requirements of this Regulation are so worded as to apply to category M<sub>1</sub> vehicles in which the driver is on the left. In category M<sub>1</sub> vehicles in which the driver is on the right these requirements shall be applied by inverting the criteria, when appropriate.

## 2. Definitions for the purpose of this Regulation

- 2.1. "*Approval of a vehicle type*" means the full procedure whereby a Contracting Party to the Agreement certifies that a vehicle type meets the technical requirements of this Regulation.
- 2.2. "*Vehicle type with regard to the field of vision*" means vehicles which do not differ in such essential aspects as:
  - 2.2.1. The external and internal forms and arrangements within the area specified in paragraph 1. above which may affect visibility; and
  - 2.2.2. The shape and dimensions of the windscreen and its mounting.
- 2.3. "*Three-dimensional reference grid*" means a reference system which consists of a vertical longitudinal plane X-Z, a horizontal plane X-Y and a vertical transverse plane Y-Z (see Annex 4, Appendix, Figure 6); the grid is used to determine the dimensional relationships between the position of design points on drawings and their positions on the actual vehicle. The procedure for situating the vehicle relative to the grid is specified in Annex 4; all coordinates referred to ground zero shall be based on a vehicle in running order<sup>2</sup> plus one front-seat passenger, the mass of the passenger being 75 kg ±1 per cent.
  - 2.3.1. Vehicles fitted with suspension enabling their ground clearance to be adjusted shall be tested under the normal conditions of use specified by the vehicle manufacturer.
- 2.4. "*Primary reference marks*" means holes, surfaces, marks and identification signs on the vehicle body. The type of reference mark used and the position of each mark relative to the X, Y and Z coordinates of the three-dimensional reference grid and to a design ground plane shall be specified by the vehicle

---

<sup>1</sup> As defined in the Consolidated Resolution on the Construction of Vehicles (R.E.3.), document ECE/TRANS/WP.29/78/Rev.2, para. 2. - [www.unece.org/trans/main/wp29/wp29wgs/wp29gen/wp29resolutions.html](http://www.unece.org/trans/main/wp29/wp29wgs/wp29gen/wp29resolutions.html)

<sup>2</sup> The mass of a vehicle in running order includes the mass of the vehicle and its body with cooling fluid, lubricants, fuel, 100 per cent of other liquids, tools, spare wheel and driver. The mass of the driver is evaluated at 75 kg (distributed as follows: 68 kg for the mass of the occupant and 7 kg for the mass of luggage, in accordance with ISO Standard 2416:1992). The tank contains 90 per cent and the other liquid-containing appliances (other than those intended for waste water) 100 per cent of the capacity declared by the manufacturer.

- manufacturer. These marks may be the control points used for body-assembly purposes.
- 2.5. "*Seat-back angle*" means the angle defined in the revised Consolidated Resolution on the Construction of Vehicles (R.E.3)<sup>3</sup>, Annex 1, paragraph 2.6. or 2.7.
- 2.6. "*Actual seat-back angle*" means the angle defined in the revised R.E.3, Annex 1, paragraph 2.6.
- 2.7. "*Design seat-back angle*" means the angle defined in the revised R.E.3, Annex 1, paragraph 2.7.
- 2.8. "*V points*" means points whose position in the passenger compartment is determined as a function of vertical longitudinal planes passing through the centres of the outermost designated seating positions on the front seat and in relation to the "R" point and the design angle of the seat-back, which points are used for verifying compliance with the field of vision requirements.
- 2.9. "*R point or seating reference point*" means the point defined in the revised R.E.3, Annex 1, paragraph 2.4.
- 2.10. "*H point*" means the point defined in the revised R.E.3, Annex 1, paragraph 2.3.
- 2.11. "*Windscreen datum points*" means points situated at the intersection with the windscreen of lines radiating forward from the V points to the outer surface of the windscreen.
- 2.12. "*Armoured vehicle*" means a vehicle intended for the protection of conveyed passengers and/or goods and complying with armour plating anti-bullet requirements.
- 2.13. "*Transparent area*" means that area of a vehicle windscreen or other glazed surface whose light transmittance measured at right angles to the surface is not less than 70 per cent. In the case of armoured vehicles, the light transmittance factor is not less than 60 per cent.
- 2.14. "*P points*" means the points about which the driver's head rotates when he views objects on a horizontal plane at eye level.
- 2.15. "*E points*" means points representing the centres of the driver's eyes and used to assess the extent to which "A" pillars obscure the field of vision.
- 2.16. "*A pillar*" means any roof support forward of the vertical transverse plane located 68 mm in front of the V points and includes non-transparent items such as windscreen mouldings and door frames, attached or contiguous to such a support.
- 2.17. "*Horizontal seat-adjustment range*" means the range of normal driving positions designated by the vehicle manufacturer for the adjustment of the driver's seat in the direction of the X axis (see paragraph 2.3. above).
- 2.18. "*Extended seat-adjustment range*" means the range designated by the vehicle manufacturer for the adjustment of the seat in the direction of the X axis (see paragraph 2.3. above) beyond the range of normal driving positions specified

---

<sup>3</sup> Revision 2 of R.E.3 is available as document ECE/TRANS/WP.29/78/Rev.2 as amended.

in paragraph 2.17. above and used for converting seats into beds or facilitating entry to the vehicle.

### **3. Application for approval**

- 3.1. The application for approval of a vehicle type with regard to the driver's field of vision shall be submitted by the vehicle manufacturer or by his authorized representative.
- 3.2. It shall be accompanied by the documents mentioned below in triplicate and include the following particulars:
  - 3.2.1. A description of the vehicle type with regard to the items mentioned in paragraph 2.2. above, together with dimensional drawings and either a photograph or an exploded view of the passenger compartment. The numbers and/or symbols identifying the vehicle type shall be specified; and
  - 3.2.2. Particulars of the primary reference marks in sufficient detail to enable them to be readily identified and the position of each in relation to the others and to the "R" point verified.
- 3.3. A vehicle representative of the vehicle type to be approved shall be submitted to the Technical Service conducting the approval tests.

### **4. Approval**

- 4.1. If the vehicle type submitted for approval pursuant to this Regulation meets the requirements of paragraph 5. below, approval of that vehicle shall be granted.
- 4.2. An approval number shall be assigned to each type approved. Its first two digits (at present 01 for the Regulation in its current form) shall indicate the series of amendments incorporating the most recent major technical amendments made to the Regulation at the time of issue of the approval. The same Contracting Party shall not assign the same number to the same vehicle type equipped with another type of field of vision, or to another vehicle type.
- 4.3. Notice of approval or of refusal or withdrawal of approval pursuant to this Regulation shall be communicated to the Parties to the Agreement which apply this Regulation by means of a form conforming to the model in Annex 1 and photographs and/or plans supplied by the applicant being in a format not exceeding A4 (210 x 297 mm), or folded to that format, and on an appropriate scale.
- 4.4. There shall be affixed, conspicuously and in a readily accessible place specified on the approval form, to every vehicle conforming to a vehicle type approved under this Regulation, an international approval mark conforming to the model described in Annex 2 to this Regulation, consisting of:

- 4.4.1. A circle surrounding the letter "E" followed by the distinguishing number of the country, which has granted approval<sup>4</sup>;
- 4.4.2. The number of this Regulation, followed by the letter "R", a dash and the approval number to the right of the circle prescribed in paragraph 4.4.1. above.
- 4.5. If the vehicle conforms to a vehicle type approved under one or more other Regulations, annexed to the Agreement, in the country, which has granted approval under this Regulation, the symbol prescribed in paragraph 4.4.1. above need not be repeated; in such a case, the Regulation and approval numbers and the additional symbols shall be placed in vertical columns to the right of the symbol prescribed in paragraph 4.4.1. above.
- 4.6. The approval mark shall be clearly legible and be indelible.
- 4.7. The approval mark shall be placed close to or on the vehicle data plate.

## 5. Specifications

- 5.1. Driver's field of vision.
  - 5.1.1. The transparent area of the windscreen shall include at least the windscreen datum points (see Annex 4, Appendix, Figure 1):
    - 5.1.1.1. A horizontal datum point forward of  $V_1$  and  $17^\circ$  to the left (see Annex 4, Appendix, Figure 1);
    - 5.1.1.2. An upper vertical datum point forward of  $V_1$  and  $7^\circ$  above the horizontal;
    - 5.1.1.3. A lower vertical datum point forward of  $V_2$  and  $5^\circ$  below the horizontal;
    - 5.1.1.4. To verify compliance with the forward-vision requirement on the opposite half of the windscreen, three additional datum points, symmetrical to the points defined in paragraphs 5.1.1.1. to 5.1.1.3. above in relation to the median longitudinal plane of the vehicle, are obtained.
  - 5.1.2. The angle of obstruction for each "A" pillar, as described in paragraph 5.1.2.1. below, shall not exceed  $6^\circ$  (see Annex 4, Appendix, Figure 3). In the case of armoured vehicles, that angle shall not exceed  $10^\circ$ .

The angle of obstruction of the "A" pillar on the passenger side, as defined in paragraph 5.1.2.1.2. below, need not be determined if the two pillars are located symmetrically in relation to the median longitudinal vertical plane of the vehicle.
  - 5.1.2.1. The angle of obstruction of each "A" pillar shall be measured by superimposing in a plane the following two horizontal sections:
    - Section 1: Starting from the Pm point situated at the location defined in paragraph 5.3.1.1. below, draw a plane forming an angle of  $2^\circ$  upwards in relation to the horizontal plane passing forward through Pm. Determine the horizontal section of the "A" pillar

---

<sup>4</sup> The distinguishing numbers of the Contracting Parties to the 1958 Agreement are reproduced in Annex 3 to the Consolidated Resolution on the Construction of Vehicles (R.E.3), document ECE/TRANS/WP.29/78/Rev.2/Amend.3 - [www.unece.org/trans/main/wp29/wp29wgs/wp29gen/wp29resolutions.html](http://www.unece.org/trans/main/wp29/wp29wgs/wp29gen/wp29resolutions.html)

starting from the foremost point of the intersection of the "A" pillar and the inclined plane (see Annex 4, Appendix, Figure 2).

Section 2: Repeat the same procedure, taking a plane declining at an angle of 5° downwards in relation to the horizontal plane passing forward through Pm (see Annex 4, Appendix, Figure 2).

- 5.1.2.1.1. The angle of obstruction of the "A" pillar on the driver's side is the angle formed on the plane view by a parallel, starting from E<sub>2</sub>, to the tangent joining E<sub>1</sub> with the outer edge of section S<sub>2</sub> and the tangent joining E<sub>2</sub> to the inner edge of section S<sub>1</sub> (see Annex 4, Appendix, Figure 3).
- 5.1.2.1.2. The angle of obstruction of the "A" pillar on the passenger side is the angle formed on the plane view by the tangent joining E<sub>3</sub> to the inner edge of section S<sub>1</sub> and a parallel, starting from E<sub>3</sub>, to the tangent joining E<sub>4</sub> to the outer edge of section S<sub>2</sub> (see Annex 4, Appendix, Figure 3).
- 5.1.2.2. No vehicle shall have more than two "A" pillars.
- 5.1.3. Except as provided in paragraph 5.1.3.3. or 5.1.3.4. below, other than the obstructions created by the "A" pillars, the fixed or movable vent or side window division bars, outside radio aerials, devices for indirect vision, covering the mandatory field of indirect vision, and windscreen wipers, there shall be no obstruction in the driver's 180° forward direct field of vision below a horizontal plane passing through V<sub>1</sub>, and above three planes through V<sub>2</sub>, one being perpendicular to the plane X-Z and declining forward 4° below the horizontal, and the other two being perpendicular to the plane Y-Z and declining 4° below the horizontal (see Annex 4, Appendix, Figure 4).

The following are not considered to be obstructions to the field of vision:

- (a) Embedded or printed "radio aerial" conductors, no wider than the following:
- (i) Embedded conductors: 0.5 mm,
  - (ii) Printed conductors: 1.0 mm. These "radio aerial" conductors shall not cross zone A<sup>5</sup>. However, three "radio aerial" conductors may cross zone A if their width does not exceed 0.5 mm.
- (b) Within zone A located "defrosting/demisting" normally in "zigzag" or sinusoidal form having the following dimensions:
- (i) Maximum visible width: 0.030 mm,
  - (ii) Maximum conductor density:
    - a. If the conductors are vertical: 8/cm,
    - b. If the conductors are horizontal: 5/cm.
- 5.1.3.1. In case of camera monitor devices, the exemptions of paragraph 5.1.3. apply to cameras including their holders and housings which are mounted to the

---

<sup>5</sup> As defined in Annex 18, paragraph 2.2. of Regulation No. 43 concerning the approval of safety glazing and glazing material.

vehicle exterior. The camera-monitor system replacing a rear-view Class I mirror shall have the same exemption.

5.1.3.2. For vehicles, which are equipped as standard with approved rear-view mirrors that are optionally replaced by camera-monitor devices, the exemptions of paragraph 5.1.3. apply also to monitors, provided:<sup>6</sup>

- (a) Their obstruction of the direct view does not exceed the level of obstruction of the corresponding exterior rear-view mirror including its housing and holder, and;
- (b) The position of the monitor is as close as practicable to the position of the rear-view mirror it replaces.

5.1.3.3. An obstruction created by the steering-wheel rim and the instrument panel inside the steering wheel will be tolerated if a plane through  $V_2$ , perpendicular to the plane  $x - z$  and tangential to the highest part of the steering-wheel rim, is declined at least  $1^\circ$  below the horizontal.

The steering wheel, if adjustable, shall be placed in the normal position indicated by the manufacturer or, failing that, midway between the limits of its range(s) of adjustment.

5.1.3.4. An obstruction between a plane through  $V_2$ , and declined at least  $1^\circ$  below the horizontal and a plane through  $V_2$  and declined  $4^\circ$  below the horizontal will be tolerated if the conical projection of this obstruction, starting from  $V_2$ , on an area "S" as defined in paragraph 5.1.3.2.1. below does not exceed 20 per cent of this area. The steering wheel, if adjustable, shall be placed in the normal position indicated by the manufacturer or, failing that, midway between the limits of its range(s) of adjustment.

5.1.3.4.1. The area "S" (see Annex 4, Appendix, Figure 7) is a rectangular vertical area located in a plane perpendicular to the X coordinate 1,500 mm forward of the point  $V_2$ . The upper edge of the area "S" is defined by a plane passing through  $V_2$  declined forward  $1^\circ$  below the horizontal. The lower edge of the area "S" is defined by a plane passing through  $V_2$  declined forward  $4^\circ$  below the horizontal. The left and right edges of the area "S" are vertical and generated from the intersection lines of the three planes declined  $4^\circ$  as defined in paragraph 5.1.2.2. above.

5.1.3.4.2. In the case of a windscreen extending beyond 1,500 mm forward of the point  $V_2$ , the distance between the area "S" and the point  $V_2$  may be extended accordingly.

5.1.4. In the case where the height of  $V_2$  above the ground exceeds 1,650 mm, the following requirement shall be met:

A 1,200 mm tall cylindrical object with a diameter of 300 mm that is situated inside the space bounded by a vertical plane located 2,000 mm in front of the vehicle, a vertical plane located 2,300 mm in front of the vehicle, a vertical plane located 400 mm from the driver's side of the vehicle, and a vertical plane located 600 mm from the opposite side of the vehicle shall be at least partially visible when viewed directly from  $V_2$  (see Figure 1), regardless of where the object is within that space, unless it is invisible due to a blind spot(s) created by the A pillars, windscreen wipers, or steering wheel.

---

<sup>6</sup> See report ECE/TRANS/WP.29/GRSG/88, paragraph 46 on the period of application of this paragraph.

If the driver's seat is located in the central driving position of the vehicle, the 1,200 mm tall cylindrical object shall be situated inside the space bounded by a vertical plane located 2,000 mm in front of the vehicle, a vertical plane located 2,300 mm in front of the vehicle, a vertical plane located 500 mm from the side of the vehicle (see Figure 2).

Figure 1

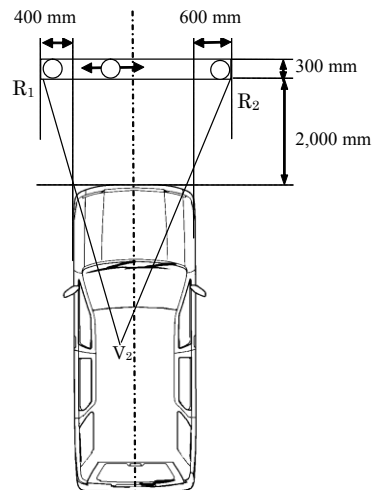
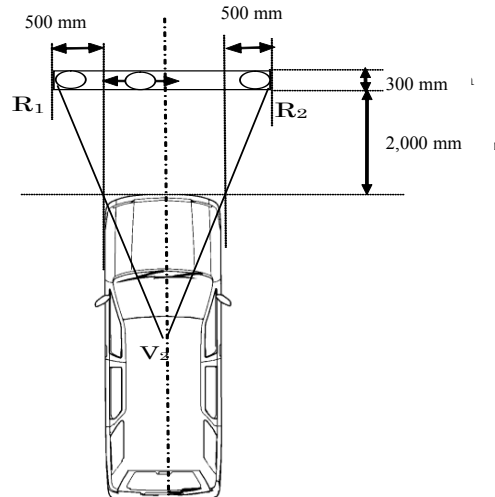

Figure 2



- 5.2. Position of the V points
  - 5.2.1. The position of the V points in relation to the "R" point, as indicated by XYZ coordinates from the three dimensional reference grid, are as shown in Tables I and IV.
  - 5.2.2. Table I indicates the basic coordinates for a design seat-back angle of 25°. The positive direction for the coordinates is indicated in Annex 4, Appendix, Figure 1.

Table I

<i>V-point</i>	<i>X</i>	<i>Y</i>	<i>Z</i>
V <sub>1</sub>	68 mm	-5 mm	665 mm
V <sub>2</sub>	68 mm	-5 mm	589 mm

- 5.3. Position of the P points
  - 5.3.1. The position of the P points in relation to the "R" point, as indicated by the XYZ coordinates from the three-dimensional reference grid, are as shown by Tables II, III and IV.
  - 5.3.1.1. Table II sets out the base coordinates for a design seat-back angle of 25°. The positive direction of the coordinates is set out in Annex 4, Appendix, Figure 1.

The Pm point is the point of intersection between the straight line joining P<sub>1</sub>, P<sub>2</sub> and the longitudinal vertical plane passing through the "R" point.

Table II

<i>Point P</i>	<i>X</i>	<i>Y</i>	<i>Z</i>

<i>Point P</i>	<i>X</i>	<i>Y</i>	<i>Z</i>
P <sub>1</sub>	35 mm	-20 mm	627 mm
P <sub>2</sub>	63 mm	47 mm	627 mm
P <sub>m</sub>	43.36 mm	0 mm	627 mm

5.3.1.2. Table III indicates the further corrections to be made to the X coordinates of P<sub>1</sub> and P<sub>2</sub> when the horizontal seat-adjustment range as defined in paragraph 2.16. above exceeds 108 mm. The positive direction for the coordinates is indicated in Annex 4, Appendix, Figure 1.

Table III

<i>Horizontal seat-adjustment range</i>	<i>Δx</i>
108 to 120 mm	-13 mm
121 to 132 mm	-22 mm
133 to 145 mm	-32 mm
146 to 158 mm	-42 mm
more than 158 mm	-48 mm

5.4. Correction for design seat-back angles other than 25°

Table IV indicates the further corrections to be made to the X and Z coordinates of each P point and each V point when the design seat-back angle is not 25°. The positive direction for the coordinates is indicated in Annex 4, Appendix, Figure 1.

Table IV

<i>Seat-back angle (in °)</i>	<i>Horizontal coordinates Δx</i>	<i>Vertical coordinates Δz</i>	<i>Seat-back angle (in °)</i>	<i>Horizontal coordinates Δx</i>	<i>Vertical coordinates Δz</i>
5	-186 mm	28 mm	23	-18 mm	5 mm
6	-177 mm	27 mm	24	-9 mm	3 mm
7	-167 mm	27 mm	25	0 mm	0 mm
8	-157 mm	27 mm	26	9 mm	-3 mm
9	-147 mm	26 mm	27	17 mm	-5 mm
10	-137 mm	25 mm	28	26 mm	-8 mm
11	-128 mm	24 mm	29	34 mm	-11 mm
12	-118 mm	23 mm	30	43 mm	-14 mm
13	-109 mm	22 mm	31	51 mm	-18 mm
14	-99 mm	21 mm	32	59 mm	-21 mm
15	-90 mm	20 mm	33	67 mm	-24 mm
16	-81 mm	18 mm	34	76 mm	-28 mm
17	-72 mm	17 mm	35	84 mm	-32 mm



<i>Seat-back angle (in °)</i>	<i>Horizontal coordinates Δx</i>	<i>Vertical coordinates Δz</i>	<i>Seat-back angle (in °)</i>	<i>Horizontal coordinates Δx</i>	<i>Vertical coordinates Δz</i>
18	-62 mm	15 mm	36	92 mm	-35 mm
19	-53 mm	13 mm	37	100 mm	-39 mm
20	-44 mm	11 mm	38	108 mm	-43 mm
21	-35 mm	9 mm	39	115 mm	-48 mm
22	-26 mm	7 mm	40	123 mm	-52 mm

5.5. Position of the E points

5.5.1. E<sub>1</sub> and E<sub>2</sub> points are each 104 mm from P<sub>1</sub>.

E<sub>2</sub> is 65 mm from E<sub>1</sub> (see Annex 4, Appendix, Figure 4).

5.5.2. The straight line joining E<sub>1</sub> and E<sub>2</sub> is rotated about P<sub>1</sub> until the tangent joining E<sub>1</sub> to the outer edge of Section 2 of the "A" pillar on the driver's side is normal to the straight line E<sub>1</sub> - E<sub>2</sub> (see Annex 4, Appendix, Figure 3).

5.5.3. E<sub>3</sub> and E<sub>4</sub> are each 104 mm from point P<sub>2</sub>. E<sub>3</sub> is 65 mm from E<sub>4</sub> (see Annex 4, Appendix, Figure 4).

5.5.4. The straight line E<sub>3</sub> - E<sub>4</sub> is rotated about P<sub>2</sub> until the tangent joining E<sub>4</sub> to the outer edge of Section 2 of the "A" pillar on the passenger's side is normal to the straight line E<sub>3</sub> - E<sub>4</sub> (see Annex 4, Appendix, Figure 3).

## 6. Test procedure

6.1. Driver's field of vision

6.1.1. The dimensional relationships between the vehicle's primary reference marks and the three - dimensional reference grid shall be determined by the procedure prescribed in Annex 4.

6.1.2. The position of the points V<sub>1</sub> and V<sub>2</sub> is determined in relation to the "R" point as indicated by the XYZ coordinates of the three-dimensional reference grid and are shown in Table I under paragraph 5.2.2. above and Table IV under paragraph 5.4. above. The windscreen datum points shall then be found from the corrected V points as prescribed in paragraph 5.1.1. above.

6.1.3. The relationship between the P points, the "R" point, and the centre-line of the driver's seating position, as indicated by XYZ coordinates from the three-dimensional reference grid, shall be determined from Tables II and III in paragraph 5.3. above. The correction for design seat-back angles other than 25° is shown in Table IV under paragraph 5.4. above.

6.1.4. The angle of obstruction (see paragraph 5.1.2. above) shall be measured in the inclined planes, as indicated in Annex 4, Appendix, Figure 2. The relationship between P<sub>1</sub> and P<sub>2</sub>, which are connected to E<sub>1</sub> and E<sub>2</sub> and E<sub>3</sub> and E<sub>4</sub> respectively, is shown in Annex 4, Appendix, Figure 5.

6.1.4.1. Straight line E<sub>1</sub> - E<sub>2</sub> shall be set as described in paragraph 5.5.2. above. The angle of obstruction of the "A" pillar on the driver's side shall be measured as specified in paragraph 5.1.2.1.1. above.

- 6.1.4.2. Straight line E<sub>3</sub> - E<sub>4</sub> shall be set as described in paragraph 5.5.4. above. The angle of obstruction of the "A" pillar on the passenger side shall then be measured as specified in paragraph 5.1.2.1.2. above.
- 6.1.5. The manufacturer may measure the angle of obstruction either on the vehicle or in the drawings. In the event of doubt, the Technical Services may require the tests be carried out on the vehicle.

## **7. Modification of vehicle type and extension of approval**

- 7.1. Every modification of the vehicle type as defined in paragraph 2.2. above shall be notified to the Type Approval Authority which approved the vehicle type. The Type Approval Authority may then either:
  - 7.1.1. Consider that the modifications made do not have an adverse effect on the conditions of the granting of the approval and grant an extension of approval;
  - 7.1.2. Consider that the modifications made affect the conditions of the granting of the approval and require further tests or additional checks before granting an extension of approval.
- 7.2. Confirmation or refusal of approval, specifying the alterations, shall be communicated by the procedure specified in paragraph 4.3. above to the Contracting Parties to the Agreement which apply this Regulation.
- 7.3. The Type Approval Authority shall inform the other Contracting Parties of the extension by means of the communication form which appears in Annex 2 to this Regulation. It shall assign a serial number to each extension, to be known as the extension number.

## **8. Conformity of production**

- 8.1. Procedures concerning conformity of production shall conform to the general provisions defined in Schedule 1 to the Agreement (E/ECE/TRANS/505/Rev.3) and meet the following requirements:
- 8.2. A vehicle approved pursuant to this Regulation shall be so manufactured as to conform to the type approved by meeting the requirements of paragraph 5. above;
- 8.3. The Type Approval Authority, which has granted approval, may at any time verify the conformity of control methods applicable to each production unit. The normal frequency of such inspections shall be once every two years.

## **9. Penalties for non-conformity of production**

- 9.1. The approval granted in respect of a vehicle type pursuant to this Regulation may be withdrawn if the requirements laid down in paragraph 8. above are not complied with.
- 9.2. If a Contracting Party withdraws an approval it had previously granted, it shall forthwith so notify the other Contracting Parties applying this Regulation by sending them a communication form conforming to the model in Annex 1 to this Regulation.

## **10. Production definitively discontinued**

If the holder of the approval completely ceases to manufacture a type of vehicle approved in accordance with this Regulation, he shall so inform the Type Approval Authority which granted the approval, which in turn shall forthwith inform the other Contracting Parties to the Agreement applying this Regulation by means of a communication form conforming to the model in Annex 1 to this Regulation.

## **11. Names and addresses of the Technical Services responsible for conducting approval tests and of Type Approval Authorities**

The Contracting Parties to the Agreement applying this Regulation shall communicate to the United Nations Secretariat the names and addresses of the Technical Services responsible for conducting approval tests and of the Type Approval Authorities, which grant approval, and to which forms certifying approval or extension or refusal or withdrawal of approval are to be sent.

## **12. Transitional provisions**

- 12.1. As from the official date of entry into force of the 01 series of amendments, no Contracting Party applying this Regulation shall refuse to grant approval under this Regulation as amended by the 01 series of amendments.
- 12.2. As from 24 months after the date of entry into force of the 01 series of amendments to this Regulation, Contracting Parties applying this Regulation shall grant approvals only if the vehicle type to be approved meets the requirements of this Regulation as amended by the 01 series of amendments.
- 12.3. Contracting Parties applying this Regulation shall not refuse to grant extensions of approvals for existing types, which have been granted according to the original version of this Regulation.
- 12.4. Even after the entry into force of the 01 series of amendments to this Regulation, type approvals of the vehicles to the original version of this Regulation shall remain valid. Contracting Parties applying this Regulation shall continue to accept them.
- 12.5. Notwithstanding the transitional provisions above, Contracting Parties whose application of this Regulation comes into force after the date of entry into force of the 01 series of amendments are not obliged to accept approvals, which were granted in accordance with the original version of this Regulation.

## Annex 1

### Communication

(maximum format: A4 (210 x 297 mm))

issued by: Name of administration:

.....  
.....  
.....



concerning<sup>2</sup>: Approval granted  
Approval extended  
Approval refused  
Approval withdrawn  
Production definitively discontinued

of a type of vehicle with regard to the driver's forward field of vision pursuant to Regulation No. 125

Approval No..... Extension No.....

1. Trademark: .....
2. Type and trade name(s): .....
3. Name and address of manufacturer: .....
4. If applicable, name and address of manufacturer's representative: .....  
.....
5. Brief description of vehicle: .....
6. Data to enable the identification of reference point "R" of the seating position designated for the driver in relation to the primary reference marks: .....  
.....
7. Identification, place and relative positions of the primary reference marks: .....
8. Date of submission of vehicle for approval: .....
9. Technical Service performing the approval tests: .....

<sup>1</sup> Distinguishing number of the country which has granted/refused/withdrawn approval (see approval provisions in the Regulation).

<sup>2</sup> Delete what does not apply.

10. Date of report issued by that Service: .....
11. Number of report issued by that Service: .....
12. Approval with regard to the driver's field of vision is granted/refused<sup>2</sup>:
13. Place: .....
14. Date: .....
15. Signature: .....
16. Annexed to this communication are the following documents, bearing the approval number indicated above:
  - ..... dimensional drawings
  - ..... exploded view or photograph of the passenger compartment
17. Any remarks: .....

## Annex 2

### Arrangements of approval marks

(see paragraphs 4.4. to 4.4.2. of this Regulation)

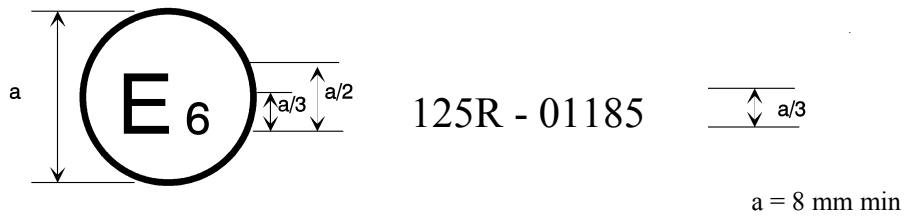

The above approval mark affixed to a vehicle shows that the vehicle type concerned has been approved in Belgium (E 6) with regard to the driver's forward field of vision pursuant to Regulation No. 125. The first two digits of the approval number indicate that the approval was granted in accordance with the requirements of Regulation No. 125 as amended by the 01 series of amendments.

## **Annex 3**

### **Procedure for determining the "H" point and the actual torso angle for seating positions in motor vehicles<sup>1</sup>**

#### **Appendix 1 - Description of the three dimensional "H" point machine (3-D H machine)<sup>1</sup>**

#### **Appendix 2 - Three-dimensional reference system<sup>1</sup>**

#### **Appendix 3 - Reference data concerning seating positions<sup>1</sup>**

---

<sup>1</sup> The procedure is described in Annex 1 to the Consolidated Resolution on the Construction of Vehicles (RE.3) (document ECE/TRANS/WP.29/78/Rev.2).  
[www.unece.org/trans/main/wp29/wp29wgs/wp29gen/wp29resolutions.html](http://www.unece.org/trans/main/wp29/wp29wgs/wp29gen/wp29resolutions.html)

## Annex 4

### **Method for determining the dimensional relationships between the vehicle's primary reference marks and the three-dimensional reference grid**

1. Relationship between reference grid and vehicle's primary reference marks  
To verify specific dimensions on or within a vehicle submitted for approval in accordance with this Regulation, the relationship between the coordinates of the three-dimensional reference grid, defined in paragraph 2.3. of this Regulation, which has been laid out at the initial vehicle-design stage, and the positions of the primary reference marks, defined in paragraph 2.4. of this Regulation, shall be established accurately so that specific points on the vehicle manufacturer's drawings can be identified on an actual vehicle produced from those drawings.
2. Method for establishing relationship of reference grid to reference marks  
For this purpose, a ground reference plane shall be constructed which is marked with the X-X measurement and the Y-Y measurement. The method of achieving this is set out in Figure 6 of the Appendix to this annex, the reference plane being a hard, flat, level surface upon which the vehicle stands, and which has two measuring scales firmly fixed to its surface; these shall be graduated in millimetres, the X-X scale being not less than eight metres long and the Y-Y scale not less than four metres long. The two scales shall be set at right angles to each other as shown in Figure 6 of the Appendix to this annex. The intersection of these scales is the ground zero.
3. Examination of the reference plane  
In order to provide for minor variations in the level of the reference plane or test area, it will be necessary to measure the deviations from ground zero along both the X and Y scales at intervals of 250 mm and to record the readings obtained so that corrections can be made when checking the vehicle.
4. Actual test attitude  
In order to provide for minor changes in suspension height, etc., it will be necessary to have available a means of bringing the reference marks to the correct coordinate positions relative to the design attitude before further measurements are taken. In addition, it shall be possible to make minor lateral and/or longitudinal adjustments of the vehicle's position so as to place it accurately in relation to the reference grid.
5. Results  
The vehicle having been correctly placed relative to the reference grid and in its design attitude, the site of the necessary points for studying the forward visibility requirements can be readily determined.  
Test methods to determine these requirements may include the use of theodolites, light sources or shadow devices, or any other method, which can be shown to give equivalent results.



## Annex 4 – Appendix

Figure 1  
Determination of V points

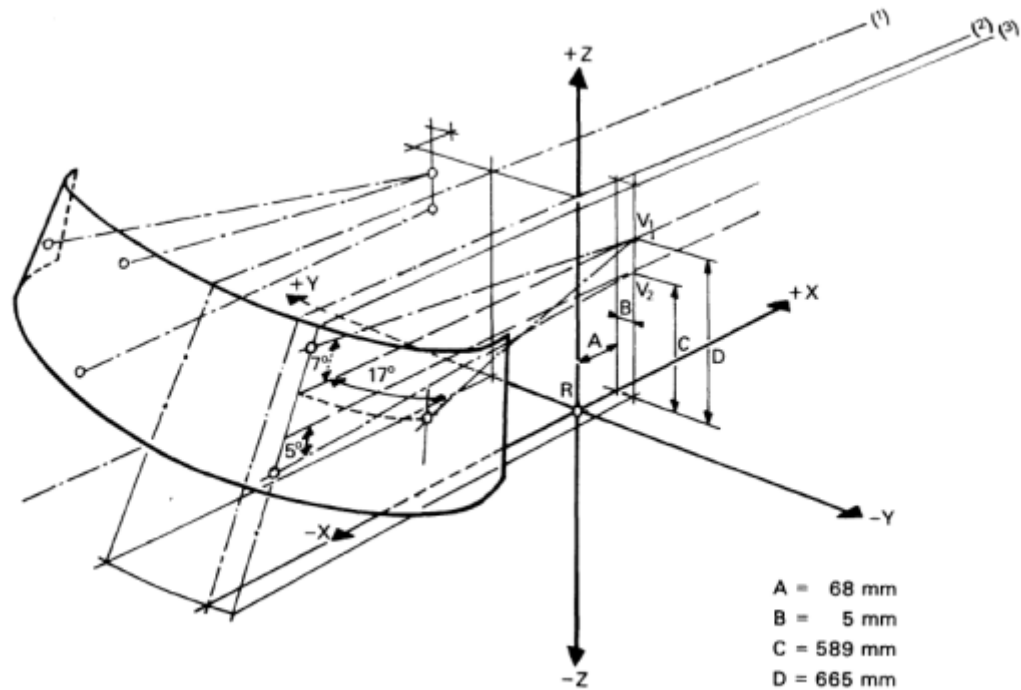

- (1) Line tracing the median longitudinal plane of the vehicle.
- (2) Line tracing the vertical plane passing through R.
- (3) Line tracing the vertical plane passing through  $V_1$  and  $V_2$ .

Figure 2  
**Observation points of the "A" pillars**

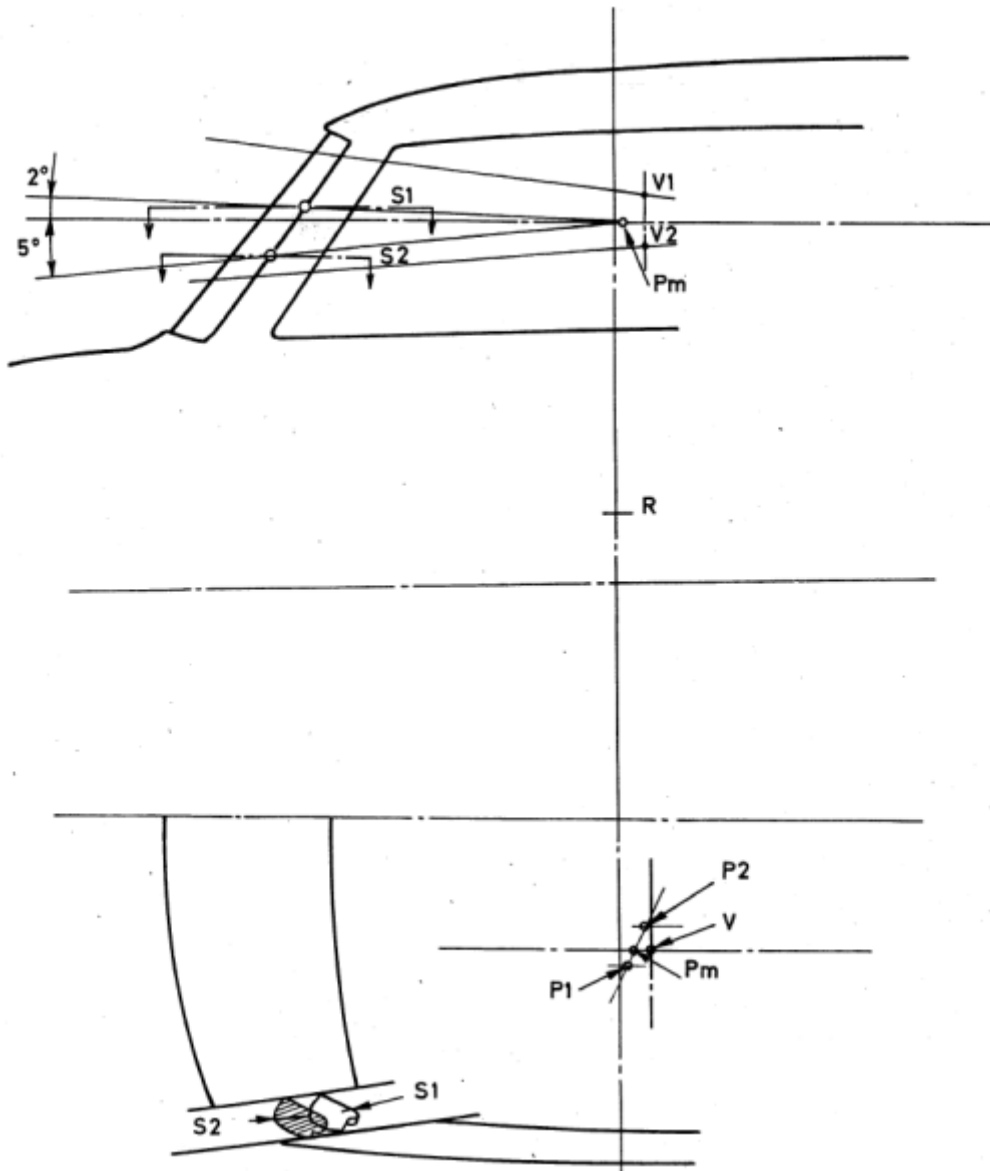

Figure 3  
**Angles of obstruction**

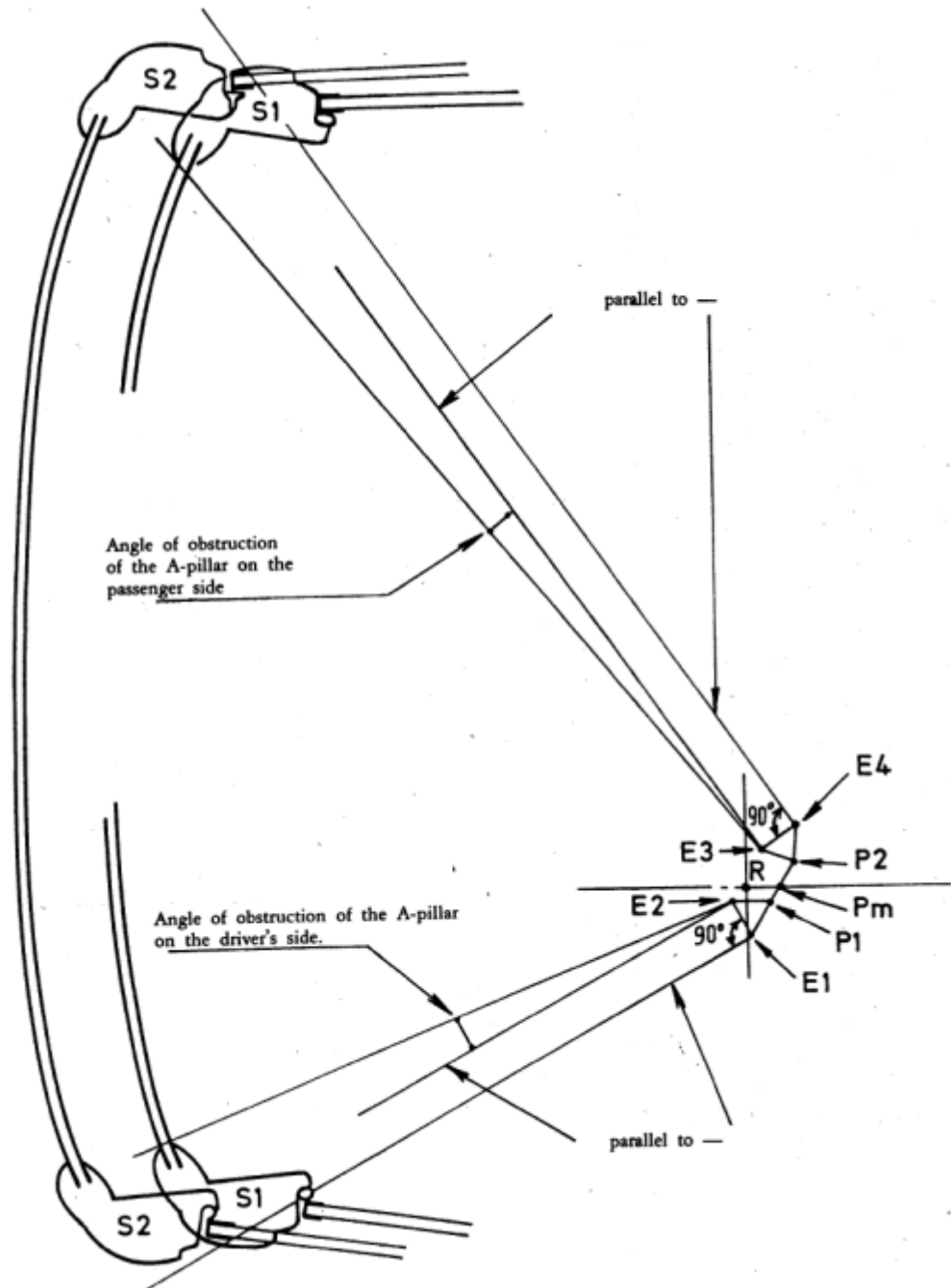

Figure 4  
**Evaluation of obstructions in the 180° forward direct field of vision of the driver**

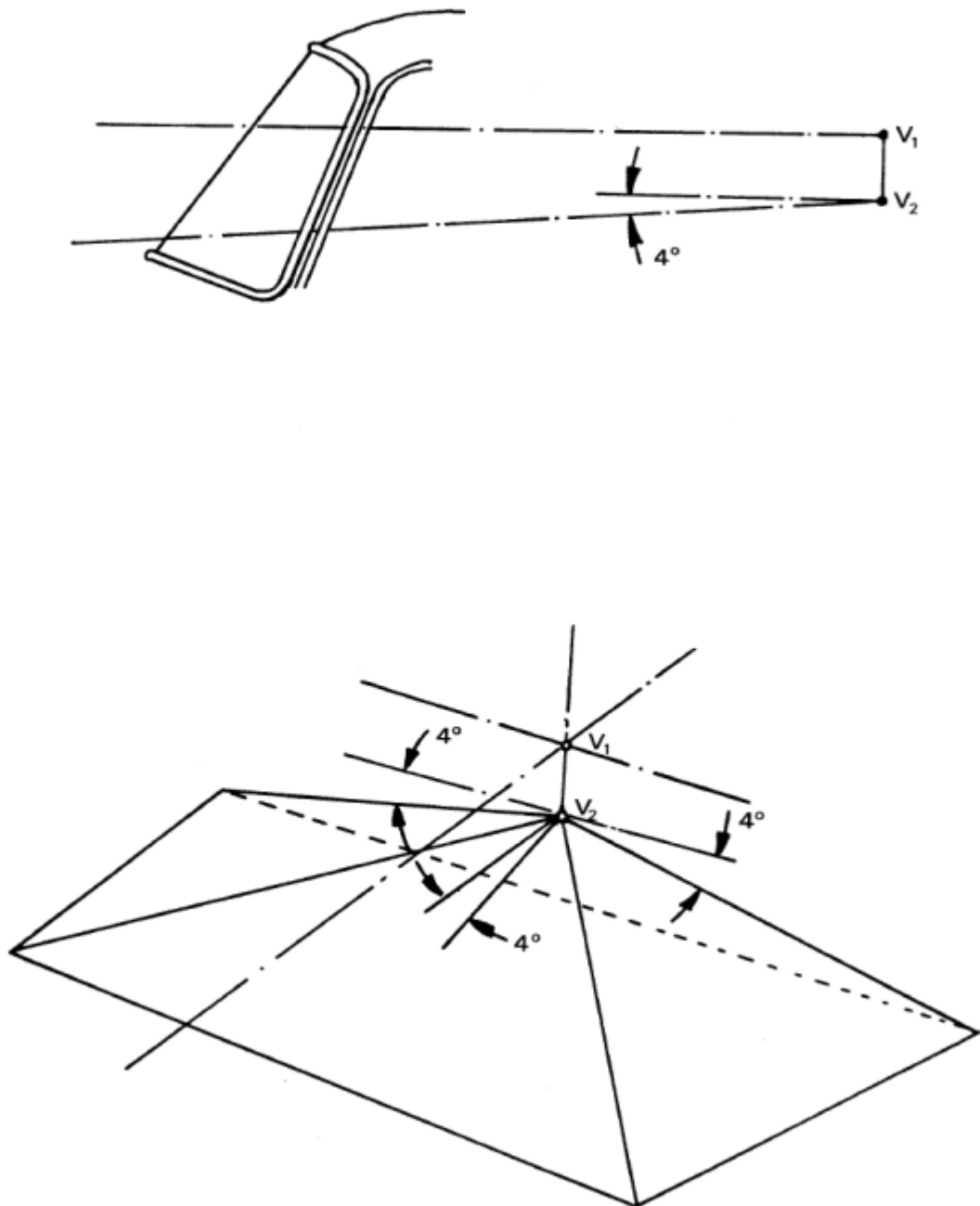

Figure 5  
**Dimensional diagram showing relative positions of E points and P points**

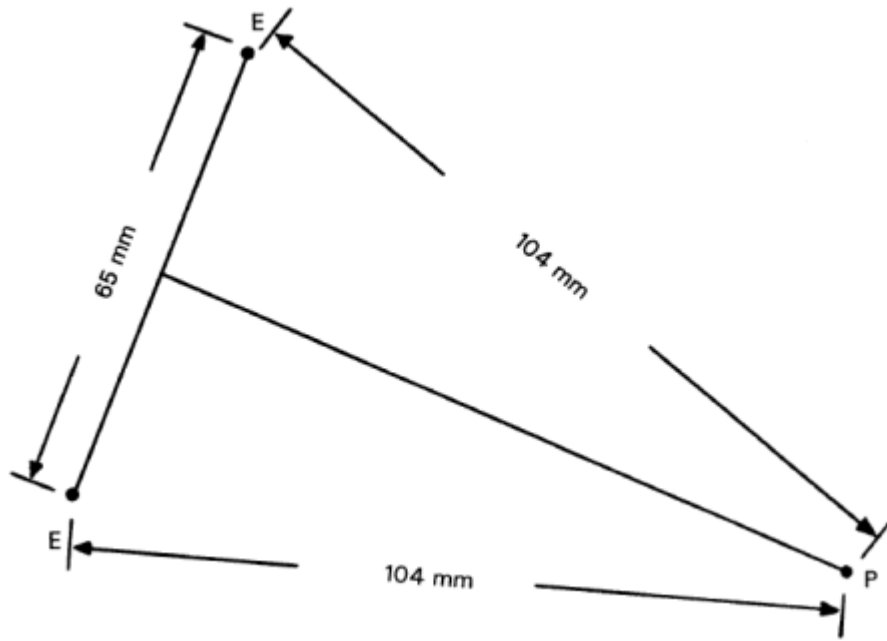

Figure 6  
**Level work place**

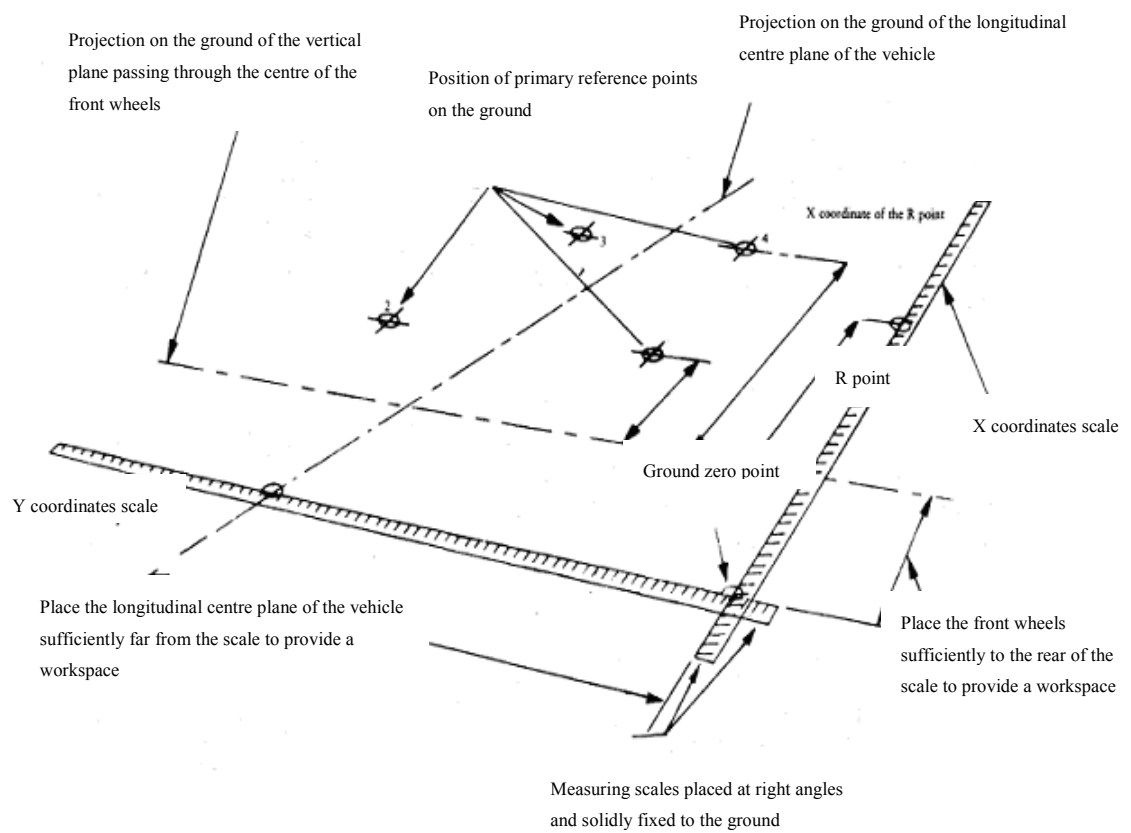

Figure 7  
**Definition of the area "S"**  
(paragraph 5.1.3.2. of this Regulation)

