



ASIC
Australian Securities &
Investments Commission

REGULATORY GUIDE 97

Disclosing fees and costs in PDSs and periodic statements

November 2019

About this guide

This guide is for:

- issuers of certain superannuation products;
- issuers of managed investment products and operators of notified foreign passport funds; and
- platform operators that operate superannuation platforms, investor directed portfolio services (IDPSs) and IDPS-like schemes.

It explains how fees and costs should be disclosed in Product Disclosure Statements (PDSs), shorter PDSs (if the shorter PDS regime applies), IDPS Guides and periodic statements.

About ASIC regulatory documents

In administering legislation ASIC issues the following types of regulatory documents.

Consultation papers: seek feedback from stakeholders on matters ASIC is considering, such as proposed relief or proposed regulatory guidance.

Regulatory guides: give guidance to regulated entities by:

- explaining when and how ASIC will exercise specific powers under legislation (primarily the Corporations Act)
- explaining how ASIC interprets the law
- describing the principles underlying ASIC's approach
- giving practical guidance (e.g. describing the steps of a process such as applying for a licence or giving practical examples of how regulated entities may decide to meet their obligations).

Information sheets: provide concise guidance on a specific process or compliance issue or an overview of detailed guidance.

Reports: describe ASIC compliance or relief activity or the results of a research project.

Document history

This guide was issued in November 2019 and is based on legislation and regulations as at the date of issue.

Previous versions:

- Superseded Regulatory Guide 97, issued November 2011, reissued November 2015, February 2017 and March 2017 (transitional version of RG 97)
- Superseded *Enhanced fee disclosure regulations: Questions and answers—An ASIC guide*, issued March 2006, updated June 2006 and May 2007, rebadged as Regulatory Guide 97 *Enhanced fee disclosure regulations: Questions and answers* on 5 July 2007

Disclaimer

This guide does not constitute legal advice. We encourage you to seek your own professional advice to find out how the Corporations Act and other applicable laws apply to you, as it is your responsibility to determine your obligations.

Examples in this guide are purely for illustration; they are not exhaustive and are not intended to impose or imply particular rules or requirements.

Contents

A	Overview	5
	Purpose of this guide	5
	Who this guide applies to	8
	Commencement date and transitional arrangements	10
	Our monitoring of compliance	12
B	Superannuation products: PDSs	13
	Fees and costs disclosure requirements for full PDSs	13
	Fees and costs disclosure requirements for shorter PDSs	24
	Costs met from reserves	26
	Calculating costs for superannuation products	27
	Disclosure of fees and costs for insurance	28
C	Superannuation products: Periodic statements	29
	Requirement to provide periodic statements	29
	Fees and costs disclosure requirements for periodic statements ...	30
	Periodic statements for defined benefit members	34
D	Managed investment products and notified foreign passport fund products: PDSs	35
	Fees and costs disclosure requirements for full PDSs	35
	Fees and costs disclosure requirements for shorter PDSs	45
	Calculating costs in management fees and costs	48
E	Managed investment products and notified foreign passport fund products: Periodic statements	50
	Requirement to provide periodic statements	50
	Fees and costs disclosure requirements for periodic statements ...	51
F	Platforms: Additional fees and costs disclosure requirements	55
	Disclosure of cost impact for accessible financial products	55
	Additional disclosure in platform PDSs and IDPS Guides	56
	Additional disclosure in platform periodic statements	57
	Other disclosure requirements	59
	Comparisons must not be misleading	59
G	Common fees and costs concepts	60
	Purchase price of an investment	60
	Fees and costs paid by third parties	61
	Fees and costs offset by other income	61
	Income-sharing arrangements	61
	Indirect costs	62
	Costs associated with derivative financial products	63
	Meaning of 'interposed vehicle'	67
	Transaction costs	75
	Performance fees	78
H	Calculating and presenting fees and costs	79
	Collecting and compiling data for fees and costs disclosures	79
	Filling in the 'Fees and costs summary'	79
	Disclosing fees and costs for multiple investment options	81
	Calculating and disclosing transaction costs	82
	Calculating and disclosing performance fees	83
	Making reasonable estimates	86
	Impact of tax on fees and costs disclosure in PDSs	87

I	Updating fees and costs information	89
	Updating fees and costs information in PDSs	89
	Requirements for significant event notices	91
	Appendix: Interposed vehicles—Examples	93
	Key terms	97
	Related information.....	104

A Overview

Key points

This guide explains how fees and costs should be disclosed in Product Disclosure Statements (PDSs), shorter PDSs (if the shorter PDS regime applies), investor directed portfolio services (IDPS) Guides, and periodic statements. It is for:

- issuers of certain superannuation products;
- issuers of managed investment products and operators of notified foreign passport funds; and
- platform operators that operate superannuation platforms, IDPSs and IDPS-like schemes.

The purpose of fees and costs disclosure is to ensure that consumers have accurate information to help their decision making. ASIC monitors compliance and has powers to stop or seek enforcement outcomes for misleading disclosure or disclosure that does not meet legal requirements.

Note 1: Some terms used in this guide (e.g. PDS, periodic statement and indirect cost) have specific meanings: see the 'Key terms' at the end of this guide.

Note 2: In this guide, references to sections, Pts, Divs and Chs are to the *Corporations Act 2001* (Corporations Act) and references to cls, regs and Schs are to the Corporations Regulations 2001 (Corporations Regulations), unless otherwise indicated.

Purpose of this guide

RG 97.1 Generally, every consumer who acquires a superannuation product, a managed investment product or a notified foreign passport fund product must receive:

- (a) a PDS when acquiring the product; and
- (b) a yearly periodic statement about the product.

RG 97.2 The purpose of fees and costs disclosure is to ensure that consumers have accurate information to help their decision making. A consistent and transparent approach to fees and costs disclosure has benefits—for consumers, issuers and market professionals: see Table 1.

Note: The fees and costs disclosure requirements discussed in this guide are set out in the Corporations Act and in the Corporations Regulations, including Schs 10, 10D and 10E to the Corporations Regulations. We have amended these requirements in [ASIC Corporations \(Disclosure of Fees and Costs\) Instrument 2019/1070](#).

RG 97.3 The purpose of this guide is to:

- (a) promote greater transparency through consistent adherence to the fees and costs disclosure requirements; and

- (b) help issuers of certain superannuation products and managed investment products, and operators of notified foreign passport funds (you), understand how to disclose fees and costs in PDSs and periodic statements.
- RG 97.4 A consistent and transparent approach to fees and costs disclosure can contribute to better financial markets. Transparent disclosure of all fees, underlying costs and conflicts of interest reflects a culture of good governance and conduct.
- RG 97.5 Financial advisers, other market professionals and the media can also use the information you publicly disclose to the market to:
- (a) advise consumers; and
- (b) analyse and benchmark the market, enhancing competition.
- RG 97.6 Disclosure may also be useful for some consumers in some contexts. For example, consumers can use disclosure of fees and costs post-purchase for reference in the event of a dispute. Disclosure alone is, however, not sufficient to drive good consumer outcomes. We encourage you to consider the outcomes for consumers who invest in the products you offer and design both the fees and costs themselves, and the information you provide about those fees and costs, to support good outcomes. For example, this could involve simplifying fees and costs to minimise consumer confusion.

Table 1: Benefits of consistent and transparent disclosure in PDSs and periodic statements

Who benefits?	What are the benefits?
Consumers	<p>Fees and costs disclosure makes important information available to consumers. It may help them to:</p> <ul style="list-style-type: none"> • compare products; and • understand the fees and costs they are charged. <p>Fees and costs are particularly important for investments that a consumer will hold for a long time (such as superannuation). This is because the effect of fees and costs on an investment can be substantial and can compound over time.</p>
Issuers	<p>Fees and costs disclosure helps keep issuers accountable and transparent. When you deduct fees and costs from an account or investment, you are dealing with members' money. Transparent disclosure of all fees, underlying costs and conflicts of interest reflects a culture of good governance and conduct.</p>
Market professionals	<p>Financial advisers and other professionals can use the information you publicly disclose to the market to:</p> <ul style="list-style-type: none"> • advise consumers; and • analyse and benchmark the market.

- RG 97.7 Although it is important that consumers consider fees and costs when making an investment decision, they should also consider other factors. For example, it is important that they consider the risks of a particular investment, the types of assets the product holds, and the likely returns. Disclosures about these other factors are not addressed in this guide. In relation to superannuation products, fees and costs disclosures also operate alongside the legislative frameworks established by the Government under which consumers are presented with, and may choose, superannuation products, and which will also influence consumer decision making.
- RG 97.8 This guide complements our general guidance on PDSs in [Regulatory Guide 168](#) *Product Disclosure Statements (and other disclosure obligations)* (RG 168) and other guidance on PDS requirements for specific types of products.

The legislative framework

- RG 97.9 This guide only concerns the fees and costs disclosure requirements of the Corporations Act and Corporations Regulations, as modified by [ASIC Corporations \(Disclosure of Fees and Costs\) Instrument 2019/1070](#). It does not discuss other relevant disclosures for consumers. For the requirements before the commencement of ASIC Corporations (Disclosure of Fees and Costs) Instrument 2019/1070, see:
- (a) [Class Order \[CO 14/1252\]](#) *Technical modifications to Schedule 10 of the Corporations Regulations*; and
 - (b) the transitional version of RG 97 (released March 2017), which can be downloaded from the [RG 97](#) landing page on ASIC's website.
- RG 97.10 The legislative framework for fees and costs disclosure is prescriptive in a number of respects and we have exercised our modification powers to clarify the legislative framework. Within the scope of our powers and the core elements of the legislative framework, we have sought to strike a balance between:
- (a) ensuring that consumers and market professionals have useful information; and
 - (b) you being able to practically comply with the fees and costs disclosure requirements.
- RG 97.11 We encourage you to carefully consider what types of consumers invest in the products you offer and how you can best disclose fees and costs (within the limits of the fees and costs disclosure requirements), and to provide other fees and costs information and tools in a way that will best meet the needs of those consumers. This will help consumers make informed decisions.

- RG 97.12 This guide seeks to provide clear information on how to comply with your obligations. However, responsibility for compliance rests with you. This guide cannot provide a decision-making tool for every decision you may need to make about disclosing fees and costs that relate to your particular products. When making such decisions, we expect you to consider the purposes of disclosing fees and costs, including, when relevant, good market practices.

Who this guide applies to

- RG 97.13 The fees and costs disclosure requirements explained in this guide apply to:

- (a) *superannuation trustees*—for PDSs and periodic statements (see Sections B and C);

Note: The fees and costs disclosure requirements do not apply to: self-managed superannuation funds (SMSFs); ‘no investment’ component (‘risk-only’) superannuation products; annuities (except market-linked annuities, including both investment-linked annuities and investment account annuities); pensions provided under regs 1.06(2), 1.06(6) or 1.06(7) of the Superannuation Industry (Supervision) Regulations 1994 (SIS Regulations); and non-investment or accumulation life insurance policies offered through superannuation.

- (b) *responsible entities and notified foreign passport fund operators*—for PDSs and periodic statements (see Sections D and E); and

- (c) *platform operators*:

- (i) *superannuation platforms and IDPS-like schemes*—for PDSs and periodic statements; and
- (ii) *IDPSs*—for IDPS Guides (see Sections B, C and F).

- RG 97.14 To help you comply with the fees and costs disclosure requirements, this guide also:

- (a) explains common concepts used in fees and costs disclosure (see Section G);
- (b) gives guidance on how to calculate and present fees and costs information (see Section H); and
- (c) explains how to ensure that your fees and costs information remains up to date (see Section I).

- RG 97.15 Superannuation entities and managed investment schemes often invest in underlying entities to gain exposure to certain investments and assets. Under the fees and costs disclosure requirements, you must disclose the fees and costs of investing in an underlying entity when it is an ‘interposed vehicle’. The tests for an ‘interposed vehicle’ are explained in Section G, and the appendix to this guide provides examples of interposed vehicles.

RG 97.16 Table 2 lists the relevant legislation for each type of entity and the location in this guide of the discussion of the legal requirements.

Table 2: Relevant legislation for fees and costs disclosure and location of guidance

Disclosure document	Location of the legal requirements	Further discussion in this guide
Superannuation products		
Full PDS	Part 7.9 of the Corporations Act, Subdiv 4C.2 of Pt 7.9 of the Corporations Regulations, and Sch 10 to the Corporations Regulations, as modified by ASIC Corporations (Disclosure of Fees and Costs) Instrument 2019/1070	See Section B at RG 97.27–RG 97.79
Shorter PDS	Part 7.9 of the Corporations Act, Subdiv 4.2B of Pt 7.9 of the Corporations Regulations, and Sch 10D to the Corporations Regulations, as modified by ASIC Corporations (Disclosure of Fees and Costs) Instrument 2019/1070	See Section B at RG 97.80–RG 97.94
Periodic statement	Part 7.9 of the Corporations Act, Pt 7.9 of the Corporations Regulations, and Pt 3 of Sch 10 to the Corporations Regulations, as modified by ASIC Corporations (Disclosure of Fees and Costs) Instrument 2019/1070 (other regulations may also apply)	See Section C at RG 97.106–RG 97.137
Managed investment products and notified foreign passport fund products		
Full PDS	Part 7.9 of the Corporations Act, Subdiv 4C.2 of Pt 7.9 of the Corporations Regulations, and Sch 10 to the Corporations Regulations, as modified by ASIC Corporations (Disclosure of Fees and Costs) Instrument 2019/1070	See Section D at RG 97.138–RG 97.190
Shorter PDS	Part 7.9 of the Corporations Act, Subdiv 4.2C of Pt 7.9 of the Corporations Regulations, and Sch 10E to the Corporations Regulations, as modified by ASIC Corporations (Disclosure of Fees and Costs) Instrument 2019/1070 See also Class Order [CO 12/749] Relief from the shorter PDS regime , which excludes certain simple managed investment schemes from the shorter PDS regime	See Section D at RG 97.191–RG 97.209
Periodic statement	Part 7.9 of the Corporations Act, Pt 7.9 of the Corporations Regulations, and Sch 10 to the Corporations Regulations, as modified by ASIC Corporations (Disclosure of Fees and Costs) Instrument 2019/1070 (other regulations may also apply)	See Section E at RG 97.214–RG 97.239
Platforms: Superannuation platforms		
Full PDS	Part 7.9 of the Corporations Act, Subdiv 4C.2 of Pt 7.9 of the Corporations Regulations, and Sch 10 to the Corporations Regulations, as modified by ASIC Corporations (Disclosure of Fees and Costs) Instrument 2019/1070	See Sections B and F at RG 97.28 and RG 97.243–RG 97.251

Disclosure document	Location of the legal requirements	Further discussion in this guide
Shorter PDS (if permitted under [CO 12/749])	Part 7.9 of the Corporations Act, Subdiv 4.2B of Pt 7.9 of the Corporations Regulations, and Sch 10D to the Corporations Regulations, as modified by ASIC Corporations (Disclosure of Fees and Costs) Instrument 2019/1070	See Sections B and F at RG 97.28 and RG 97.243
Periodic statement	Part 7.9 of the Corporations Act, Pt 7.9 of the Corporations Regulations, and Pt 3 of Sch 10 to the Corporations Regulations, as modified by ASIC Corporations (Disclosure of Fees and Costs) Instrument 2019/1070 (other regulations may also apply)	See Section F at RG 97.252–RG 97.257
Platforms: IDPS-like schemes		
Full PDS	Part 7.9 of the Corporations Act, Subdiv 4C.2 of Pt 7.9 of the Corporations Regulations, and Sch 10 to the Corporations Regulations, as modified by ASIC Corporations (Disclosure of Fees and Costs) Instrument 2019/1070	See Section F at RG 97.243–RG 97.251
Periodic statements	Part 7.9 of the Corporations Act, Pt 7.9 of the Corporations Regulations, and Pt 3 of Sch 10 to the Corporations Regulations, as modified by ASIC Corporations (Disclosure of Fees and Costs) Instrument 2019/1070 (other regulations may also apply)	See Section F at RG 97.252–RG 97.257
Platforms: IDPSs		
IDPS Guide	An IDPS Guide must provide information about fees and costs in relation to the IDPS that complies with Pt 2 of Sch 10 to the Corporations Regulations as if an interest in the IDPS were a managed investment product: see s912AD, as notionally inserted by Class Order [CO 13/763] <i>Investor directed portfolio services</i> .	See Section F at RG 97.258

Managed discretionary account (MDA) providers

- RG 97.17 When an MDA provider issues a Financial Services Guide (FSG), it must provide information about fees and costs in relation to its MDA services that complies with Pt 2 of Sch 10 to the Corporations Regulations as if the client were being offered a managed investment product: see s912AEA, as notionally inserted by [ASIC Corporations \(Managed Discretionary Account Services\) Instrument 2016/968](#). Part 2 of Sch 10 as it relates to managed investment products is discussed in Section D of this guide. For further guidance on MDAs, see [Regulatory Guide 179](#) *Managed discretionary accounts* (RG 179).

Commencement date and transitional arrangements

- RG 97.18 This guide provides guidance and policy on the fees and costs regime as updated in November 2019. This guide describes the regime as it will apply after the relevant transitional periods have ended. Under Pt 4 of [ASIC](#)

[Corporations \(Disclosure of Fees and Costs\) Instrument 2019/1070](#), the new requirements will apply to:

- (a) PDSs issued on or after 30 September 2020; and
- (b) periodic statements (ongoing or on exit) for reporting periods that commence on or after 1 July 2021 (see Table 3).

RG 97.19 For the requirements that apply before the commencement of ASIC Corporations (Disclosure of Fees and Costs) Instrument 2019/1070, see:

- (a) [\[CO 14/1252\]](#); and
- (b) the transitional version of RG 97 (released March 2017), which can be downloaded from the [RG 97](#) landing page on ASIC's website.

RG 97.20 Although the transitional version of RG 97 will continue to apply during the transitional period, industry can obtain immediate benefit from the clearer guidance in this updated version of RG 97 about existing fees and costs disclosure requirements that have not changed.

Table 3: When the requirements apply and our related guidance

Disclosure document	Commencement date and related guidance	Opt-in-early arrangements
PDS	<p>For PDSs issued before 30 September 2020, you must comply with [CO 14/1252]. The transitional version of RG 97 (released March 2017) applies to these PDSs.</p> <p>For PDSs issued on or after 30 September 2020, you must comply with ASIC Corporations (Disclosure of Fees and Costs) Instrument 2019/1070. The updated version of RG 97 (released November 2019) applies to these PDSs.</p>	You cannot opt in before the commencement date (see RG 97.23).
Periodic statement	<p>For periodic statements (ongoing or on exit) for reporting periods that commence before 1 July 2021, you must comply with [CO 14/1252]. The transitional version of RG 97 (released March 2017) applies to these periodic statements.</p> <p>For periodic statements (ongoing or on exit) for reporting periods that commence on or after 1 July 2021, you must comply with ASIC Corporations (Disclosure of Fees and Costs) Instrument 2019/1070. The updated version of RG 97 (released November 2019) applies to these periodic statements.</p>	<p>You may opt in to the updated requirements if the periodic statement is for a reporting period that:</p> <ul style="list-style-type: none"> • commences on or after 1 July 2020; or • ends on a day that is on or after 1 July 2020 if the reporting period ends on the exit date because the holder of the product ceased to hold the product on the exit date (see RG 97.21–RG 97.22).

Opting in early to the new requirements

- RG 97.21 An issuer may elect to apply the new requirements in ASIC Corporations (Disclosure of Fees and Costs) Instrument 2019/1070 to a periodic statement for a reporting period that:
- (a) commences on or after 1 July 2020; or
 - (b) ends on a day that is on or after 1 July 2020 if the reporting period ends on the exit date because the holder of the product ceased to hold the product on the exit date.
- RG 97.22 An issuer that elects to apply the requirements to a periodic statement for an earlier reporting period must make a written record of:
- (a) the financial products to which the election relates;
 - (b) the reporting periods to which the election relates; and
 - (c) the date or dates the election is made.
- RG 97.23 To ensure consistent and comparable fees and costs disclosure in PDSs, issuers will not be able to ‘opt-in’ early to the new requirements for PDSs.

Our monitoring of compliance

- RG 97.24 We aim to ensure that:
- (a) issuers comply with the disclosure requirements, including the fees and costs disclosure requirements; and
 - (b) consumers are provided with accurate information to help their decision making.
- RG 97.25 We review PDSs, periodic statements and marketing materials to promote this outcome.
- RG 97.26 ASIC has powers to stop, or seek enforcement outcomes in relation to, misleading disclosure, disclosure that does not contain all relevant information, or disclosure that does not meet legal requirements (such as making a stop order under s1020E).

B Superannuation products: PDSs

Key points

This section explains the fees and costs disclosure requirements for PDSs for superannuation products. The requirements are different, depending on whether you are using a full PDS or a shorter PDS. The requirements for a shorter PDS are derived directly from the requirements for a full PDS.

You will need to prepare the following information for any superannuation product requiring a full PDS:

- a 'Consumer advisory warning';
- a 'Fees and costs summary';
- an 'Example of annual fees and costs';
- 'Cost of product information'; and
- 'Additional explanation of fees and costs' (see RG 97.27–RG 97.79).

A shorter PDS must include:

- a 'Consumer advisory warning';
- a 'Fees and costs summary';
- an 'Example of annual fees and costs'; and
- other fees and costs information (see RG 97.80–RG 97.94).

This section also provides guidance on:

- the requirement to include amounts paid from reserves in your calculations (see RG 97.95–RG 97.99);
- how to calculate costs for superannuation products (see RG 97.100–RG 97.102); and
- how to disclose fees and costs for insurance (see RG 97.103–RG 97.105).

Note: You should also refer to Sections G and H for further guidance on particular fees and costs concepts, and how to calculate and present fees and costs. In the guidance below, we have included cross-references to relevant parts of those sections.

Fees and costs disclosure requirements for full PDSs

- RG 97.27 Most issuers of superannuation products must prepare shorter PDSs (including for MySuper products). However, there are exceptions and a full PDS is required for a superannuation product that is:
- (a) an interest that is solely a defined benefit interest;
 - (b) solely a pension product; or
 - (c) a risk-only superannuation product (see reg 7.9.11K).

- RG 97.28 [\[CO 12/749\]](#) provides that certain other superannuation products (such as superannuation platforms) are also generally excluded from using a shorter PDS.
- RG 97.29 In preparing a full PDS for a superannuation product, you must include a ‘Fees and other costs’ section comprising:
- (a) a ‘Consumer advisory warning’;
 - (b) a ‘Fees and costs summary’;
 - (c) an ‘Example of annual fees and costs’;
 - (d) ‘Cost of product information’; and
 - (e) ‘Additional explanation of fees and costs’ (see reg 7.9.16N).
- RG 97.30 You must also include the consumer-facing definitions for the fees set out in cl 209A of Sch 10. These consumer-facing definitions can either be set out in the ‘Fees and other costs’ section of the full PDS or incorporated by reference. For further information on incorporation by reference, see reg 7.9.15DA. For further information on these fees, see RG 97.35–RG 97.53.

‘Consumer advisory warning’

- RG 97.31 You must include a ‘Consumer advisory warning’ at the beginning of the ‘Fees and other costs’ section of a full PDS for a superannuation product: see reg 7.9.16N(2)(c) and cl 222(1) of Sch 10. The content of the ‘Consumer advisory warning’ is set out in cl 221(1) of Sch 10. You must not make any changes or additions to this warning. Figure 1 shows the text of the ‘Consumer advisory warning’.

Figure 1: ‘Consumer advisory warning’ for superannuation products

<p>DID YOU KNOW?</p> <p>Small differences in both investment performance and fees and costs can have a substantial impact on your long-term returns.</p> <p>For example, total annual fees and costs of 2% of your account balance rather than 1% could reduce your final return by up to 20% over a 30-year period (for example, reduce it from \$100,000 to \$80,000).</p> <p>You should consider whether features such as superior investment performance or the provision of better member services justify higher fees and costs.</p> <p>You or your employer, as applicable, may be able to negotiate to pay lower fees. Ask the fund or your financial adviser.</p> <p>TO FIND OUT MORE</p> <p>If you would like to find out more, or see the impact of the fees based on your own circumstances, the Australian Securities and Investments Commission (ASIC) MoneySmart website (www.moneysmart.gov.au) has a superannuation calculator to help you check out different fee options.</p>
--

'Fees and costs summary'

- RG 97.32 You must include a 'Fees and costs summary' in a full PDS for superannuation products: see reg 7.9.16N(2)(a). The content is set out in cl 201 of Sch 10. It contains a table separated into 'Ongoing annual fees and costs' and 'Member activity related fees and costs'.
- RG 97.33 The items show the significant fees and costs members will be charged. Figure 2 shows the 'Fees and costs summary' that you must complete for your superannuation product. For information on how to complete the 'Fees and costs summary', see RG 97.54–RG 97.55 and RG 97.352–RG 97.361. For more on the line items, see RG 97.35–RG 97.53 and RG 97.352–RG 97.361.

Figure 2: 'Fees and costs summary' for superannuation products

Fees and other costs

This section shows fees and other costs that you may be charged. These fees and other costs may be deducted from your money, from the returns on your investment or from the assets of the superannuation entity as a whole.

Other fees, such as activity fees, advice fees for personal advice and insurance fees, may also be charged, but these will depend on the nature of the activity, advice or insurance chosen by you. Entry and exit fees cannot be charged.

Taxes, insurance fees and other costs relating to insurance are set out in another part of this document.

You should read all the information about fees and other costs because it is important to understand their impact on your investment.

[If relevant] The fees and other costs for each MySuper product offered by the superannuation entity, and each investment option offered by the entity, are set out on page *[insert page number]*.

Fees and costs summary

<i>[Name of superannuation product]</i>		
Type of fee or cost	Amount	How and when paid
Ongoing annual fees and costs¹		
<i>Administration fees and costs</i>		
<i>Investment fees and costs²</i>		
<i>Transaction costs</i>		
Member activity related fees and costs		
<i>Buy–sell spread</i>		
<i>Switching fee</i>		
<i>Other fees and costs³</i>		

1. If your account balance for a product offered by the superannuation entity is less than \$6,000 at the end of the entity's income year, certain fees and costs charged to you in relation to administration and investment are capped at 3% of the account balance. Any amount charged in excess of that cap must be refunded.
2. [Where the amount for performance fees is zero or positive, insert a footnote *Investment fees and costs includes an amount of x.xx% for performance fees. The calculation basis for this amount is set out under "Additional explanation of fees and costs"*. Where the amount for performance fees is negative, insert a footnote *Information about performance fees is set out under "Additional explanation of fees and costs"*.]
3. *[If there are other fees and costs, such as activity fees, advice fees for personal advice or insurance fees, include a cross-reference to the "Additional explanation of fees and costs".]*

Explanation of ‘Ongoing annual fees and costs’

RG 97.34 As shown in Figure 2, the ‘Ongoing annual fees and costs’ comprise:

- (a) administration fees and costs;
- (b) investment fees and costs; and
- (c) transaction costs.

Administration fees and costs

RG 97.35 Administration fees and costs are defined in cl 101 of Sch 10. They are fees and costs that relate to the administration or operation of the superannuation entity to which the product relates and include distribution costs and:

- (a) costs that relate to administration or operation met through the use of reserves (for more information on costs met through the use of reserves, see RG 97.95–RG 97.99);
- (b) indirect costs that relate to administration or operation (for more information on indirect costs, see RG 97.271–RG 97.282); and
- (c) intrafund advice costs (see RG 97.37).

RG 97.36 Administration fees and costs do not include:

- (a) transaction costs (for more information on transaction costs, see RG 97.331–RG 97.341);
- (b) excluded transactional and operational costs (for more information on excluded transactional and operational costs, see RG 97.342–RG 97.346); and
- (c) costs charged as another type of fee or cost.

RG 97.37 Intrafund advice costs are costs incurred by the superannuation trustee of the superannuation entity for making available to all members, and providing to one or more of those members, financial product advice in relation to the product: see cl 101 of Sch 10. If the trustee provides financial product advice to a member that is not included within the definition of intrafund advice, the cost of that advice is captured as an advice fee and disclosed as ‘Other fees and costs’: see footnote 3 to the ‘Fees and costs summary’ in Figure 2.

RG 97.38 Examples of the types of things that may be included in administration fees and costs are:

- (a) fees charged by the superannuation trustee for the administration and operation of the superannuation entity;
- (b) costs of administration or custody services;
- (c) audit costs;
- (d) product development costs;
- (e) costs of providing member communications;

- (f) costs of professional indemnity insurance, directors' and officers' insurance, and other superannuation trustee insurances;
- (g) staff costs for member services teams and product teams; and
- (h) overheads (such as information technology costs and accommodation).

Investment fees and costs

- RG 97.39 Investment fees and costs are defined in cl 101 of Sch 10. They are fees and costs that relate to the investment of the assets of a superannuation entity, and specifically include:
- (a) fees in payment for the exercise of care and expertise in the investment of those assets (including performance fees);
 - (b) costs that relate to the investment of the assets of the entity that are met through the use of reserves (for more information on costs met through the use of reserves, see RG 97.95–RG 97.99); and
 - (c) indirect costs that relate to the investment of assets of the entity (for more information on indirect costs, see RG 97.271–RG 97.282).
- RG 97.40 Investment fees and costs do not include:
- (a) transaction costs (for more information on transaction costs, see RG 97.43–RG 97.44);
 - (b) excluded transactional and operational costs (for more information on excluded transactional and operational costs, see RG 97.342–RG 97.346); and
 - (c) costs charged as another type of fee or cost.
- RG 97.41 Examples of the types of things that may be included in investment fees and costs are:
- (a) fees charged by the superannuation trustee that relate to investing the assets of the superannuation entity;
 - (b) investment fees charged by an interposed vehicle (for more information on interposed vehicles, see RG 97.300–RG 97.330);
 - (c) fees charged either by the investment manager appointed by the superannuation trustee or an interposed vehicle;
 - (d) custody fees charged by either a custodian appointed by the superannuation trustee or an interposed vehicle (other than those charged as administration fees and costs);
 - (e) internal staff costs for investment-related teams;
 - (f) fees paid to asset consultants; and
 - (g) valuation costs.
- RG 97.42 For information on performance fees, see RG 97.347–RG 97.350.

Transaction costs

- RG 97.43 Transaction costs are defined in cl 103(1) of Sch 10. Transaction costs are costs of the superannuation entity associated with acquiring or disposing of assets: for more information on transaction costs, see RG 97.331–RG 97.341.
- RG 97.44 In the ‘Fees and costs summary’, transaction costs are shown net of amounts recovered by the buy–sell spread charged by the superannuation trustee: see cl 204A of Sch 10. Transaction costs are shown in this way to highlight the costs that may affect a member’s investment, as some transaction costs will be paid for by members who are charged the buy–sell spread when they enter or exit a superannuation product: for information on the buy–sell spread, see RG 97.46–RG 97.47.

Explanation of ‘Member activity related fees and costs’

- RG 97.45 In addition to the ‘Ongoing annual fees and costs’, ‘Member activity related fees and costs’ can also be charged. As shown in Figure 2, they can comprise:
- (a) a buy–sell spread;
 - (b) a switching fee; and
 - (c) other fees and costs.

Buy–sell spread

- RG 97.46 A buy–sell spread is a fee to recover costs incurred by the superannuation trustee in relation to the sale and purchase of assets of the superannuation entity: see cl 101 of Sch 10. This is charged to the member on entry or exit from the superannuation product or investment option.
- RG 97.47 A buy–sell spread that relates to an underlying investment of the superannuation entity forms part of transaction costs: see RG 97.340–RG 97.341.

Switching fee

- RG 97.48 For MySuper products, a switching fee is a fee to recover the costs of switching all or part of the member’s interest in the superannuation entity from one class of beneficial interest in the entity to another: see cl 101 of Sch 10.
- RG 97.49 For superannuation products other than a MySuper product, a switching fee is a fee to recover the costs of switching all or part of the member’s interest in the superannuation entity from one product or investment option, or product in the entity, to another: see cl 101 of Sch 10.

Other fees and costs

- RG 97.50 These can include activity fees charged when the superannuation trustee undertakes activities for a member:
- (a) at the member's request;
 - (b) with the member's consent; or
 - (c) that are required by law.
- RG 97.51 Activity fees do not include costs charged as another type of fee or cost (e.g. administration fees and costs): see cl 101 of Sch 10. Examples of activity fees are fees charged for supplying information or dealing with superannuation accounts for family law purposes.
- RG 97.52 Examples of other fees that may be included in 'Other fees and costs' include dishonoured payment fees, fees for providing a member with personal advice, and insurance fees.
- RG 97.53 If there is an item under 'Other fees and costs', you must include a cross-reference to the 'Additional explanation of fees and costs', where an additional explanation of the 'Other fees and costs' must be provided: see cl 209(a) of Sch 10.

How to fill in the 'Fees and costs summary'

- RG 97.54 You must ensure that fee information for each MySuper product and each investment option is set out in the 'Fees and costs summary', or that the summary contains a cross-reference to another section of the PDS that contains the relevant fee information: see cl 205 of Sch 10.
- RG 97.55 Some fees or costs may be charged across a MySuper product and other investment options in the superannuation entity. If this is the case, you must appropriately apportion the fees and costs so that the amounts in the 'Fees and costs summary' for each product or option reflect that portion of the fees or costs that relate to that particular product or option.
- RG 97.56 For further information on how to fill in the 'Fees and costs summary', see RG 97.352–RG 97.361.

'Example of annual fees and costs'

- RG 97.57 You must include an 'Example of annual fees and costs' in the 'Fees and other costs' section of a full PDS for superannuation products, following the 'Fees and costs summary': see reg 7.9.16N(2)(b) and cl 210(c) of Sch 10. An 'Example of annual fees and costs' is not required for defined benefit funds: see cl 213 of Sch 10.

RG 97.58 You must set out the ‘Example of annual fees and costs’ using the headings and form in cl 211 of Sch 10: see cl 210(b) of Sch 10. Figure 3 shows the ‘Example of annual fees and costs’ that you must complete for your superannuation product.

Figure 3: ‘Example of annual fees and costs’ for superannuation products

Example of annual fees and costs for superannuation products

This table gives an example of how the ongoing annual fees and costs for the *[insert name of generic MySuper product or other investment option as required by subclause 220(1)]* for this superannuation product can affect your superannuation investment over a 1-year period. You should use this table to compare this superannuation product with other superannuation products.

EXAMPLE— <i>[insert name of generic MySuper product or other investment option as required by subclause 220(1)]</i>		BALANCE OF \$50,000
Investment fees and costs	[]	For every \$50,000 you have in the superannuation product, you will be charged or have deducted from your investment \$[] each year
PLUS Administration fees and costs	[]	And , you will be charged \$[] in administration fees and costs regardless of your balance
PLUS Transaction costs	[]	And , you will be charged \$[] in transaction costs
EQUALS Cost of product		If your balance was \$50,000, at the beginning of the year, then for that year you will be charged fees of \$[] for the superannuation product.

Note:* Additional fees may apply.

How to fill in the ‘Example of annual fees and costs’

RG 97.59 We expect you to base the ‘Example of annual fees and costs’ on your generic MySuper product. If you do not offer a generic MySuper product, base the example on:

- (a) *when a balanced investment option is offered*—the balanced investment option under which most assets of the superannuation entity are invested; or
- (b) *when no balanced investment option is offered*—the investment option under which most assets of the superannuation entity are invested (see cl 220(1) of Sch 10).

RG 97.60 The fees and costs stated in the ‘Example of annual fees and costs’ must be typical ongoing fees that apply to the MySuper product or investment option. They should not be based on ‘honeymoon’ rates and must be consistent with the statement for an existing member having the stated balance and level of contributions each year: see cl 214 of Sch 10.

- RG 97.61 If the minimum balance required to join the superannuation entity is greater than \$50,000, the ‘Example of annual fees and costs’ must be based on an amount that is the lowest multiple of \$50,000 that exceeds the minimum balance: see cl 215 of Sch 10.
- RG 97.62 When investment fees and costs, administration fees and costs, or transaction costs, are disclosed as a range, the ‘Example of annual fees and costs’ must use the highest fees and costs in the range: see cl 218(2), (4) and (4B) of Sch 10. Also, the calculation of the fees and costs to be disclosed must not take into account contributions that may be made during the year: see the notes to cl 218(1), (3) and (4A) of Sch 10. When the amount for performance fees calculated under cl 101C is negative, the amount of performance fees included in the investment fees and costs must be ‘0’: see cl 218(3A) of Sch 10.
- RG 97.63 If the ‘Example of annual fees and costs’ is for a lifecycle MySuper product, the investment fees and costs quoted must be the highest investment fee for a lifecycle stage of the lifecycle MySuper product: see cl 214A of Sch 10.
- RG 97.64 We encourage you to provide calculators or other tools elsewhere, on your fund website, so that members can calculate the fees they will be charged for the superannuation product using a balance other than \$50,000.

‘Cost of product information’

- RG 97.65 You must also include ‘Cost of product information’ for each MySuper product and investment option in the ‘Fees and other costs’ section of a full PDS for superannuation products, following the ‘Example of annual fees and costs’: see reg 7.9.16N(2)(b) and cl 220A(1)(a) of Sch 10.
- RG 97.66 As the ‘Example of annual fees and costs’ is only provided for one product or investment option (see RG 97.59), the ‘Cost of product information’ is designed to give consumers an abbreviated example of how fees and costs can affect their investment if they choose to invest in one of the other products or options offered in your full PDS.
- RG 97.67 You must calculate the ‘Cost of product information’ using the method for calculating the ‘Example of annual fees and costs’ shown in Div 6 of Sch 10: see cl 220A(1)(d) of Sch 10.
- RG 97.68 You do not need to provide ‘Cost of product information’:
- (a) for a defined benefit superannuation fund (see cl 220A(2) of Sch 10); or
 - (b) when a PDS relates to only one product or investment option and an ‘Example of annual fees and costs’ has been included for that product or option (see cl 220A(3) of Sch 10).

- RG 97.69 Figure 4 shows the heading and text (the ‘preamble’) you must include immediately before presenting the first ‘Cost of product information’.

Figure 4: Preamble for ‘Cost of product information’ for superannuation products

Cost of product for 1 year

The cost of product gives a summary calculation about how ongoing annual fees and costs can affect your superannuation investment over a 1-year period for all superannuation products and investment options. It is calculated in the manner shown in the Example of annual fees and costs.

The cost of product information assumes a balance of \$50,000 at the beginning of the year. (Additional fees such as a buy–sell spread may apply: refer to the Fees and costs summary for the relevant superannuation product or investment option.)

You should use this figure to help compare superannuation products and investment options.

- RG 97.70 Figure 5 shows the form you must use when setting out the ‘Cost of product information’.

Figure 5: Form for ‘Cost of product information’ for superannuation products

<i>[Insert name of superannuation product or investment option]</i>	Cost of product \$[]
---	--------------------------

‘Additional explanation of fees and costs’

- RG 97.71 You must include an ‘Additional explanation of fees and costs’ in a full PDS for a superannuation product: see reg 7.9.16N(2)(a). You must include all the information listed in cl 209 of Sch 10 to the extent that information is relevant to the superannuation product. This can include information on:

- (a) performance fees (for more information on performance fees, see RG 97.347–RG 97.350); and
- (b) transaction costs (for more information on transaction costs, see RG 97.43–RG 97.44 and RG 97.331–RG 97.341).

- RG 97.72 If you provide intrafund advice, you must also provide an explanation of intrafund advice costs: see cl 209(f) of Sch 10. The explanation should include:

- (a) a statement that intrafund advice costs are included in administration fees and costs; and
- (b) a cross-reference to another section of the PDS or to another place (such as the superannuation trustee’s website) where the member can find out more about intrafund advice services.

- RG 97.73 You must also provide an explanation of advice fees paid for providing financial product advice to a member: see cl 209(f) of Sch 10.
- Note: The prohibition on paying or receiving conflicted remuneration and the sole purpose test restrict the payments that can be made in relation to financial product advice: see Subdiv C of Div 4 of Pt 7.7A of the Corporations Act and s62 of the *Superannuation Industry (Supervision) Act 1993* (SIS Act).
- RG 97.74 If the superannuation product offers insurance, you must include a cross-reference to the insurance section of the PDS: see cl 209(ca) of Sch 10. For more information on disclosing fees and costs for insurance, see RG 97.103–RG 97.105.
- RG 97.75 If the superannuation product is subject to tax, you must:
- (a) include a cross-reference to the tax section of the PDS (see cl 209(c) of Sch 10); and
 - (b) state whether the benefit of any tax deduction is passed on to the member in the form of a reduced fee or cost (see cl 209(d) of Sch 10).
- RG 97.76 You must also include relevant information on:
- (a) your right to change the amount of fees and the period of advance notice required to do so; and
 - (b) any change in fee structure that is dependent on a person's employment (see cl 209(k) of Sch 10).
- RG 97.77 If you have instituted a flexible charging structure, the 'Additional explanation of fees and costs' must include, for each applicable fee:
- (a) any maximum, and when it would apply; and
 - (b) any waiver, and when it would apply (see cl 209(l) of Sch 10).
- Note: We consider a waiver to be any possible reduction in the amount of the fees and costs disclosed in the 'Fees and costs summary', including through a rebate.
- RG 97.78 We consider the requirement in RG 97.77 applies to fees that are shown as part of a line item in the 'Fees and costs summary' or are mentioned in the footnotes.
- RG 97.79 We expect you to consider what other information is appropriate to include in the 'Additional explanation of fees and costs'. You should ensure that any other information is shown in a clear, concise and effective manner, as required by s1013C(3). When providing any other information, we encourage you to consider how you can disclose this information in a way that best meets the needs of the types of consumers who invest in your superannuation product.

Fees and costs disclosure requirements for shorter PDSs

- RG 97.80 As set out in RG 97.27, most issuers of superannuation products must prepare a shorter PDS. The shorter PDS regime for superannuation products is facilitated by regulations that modify the Corporations Act: see Pt 5B of Sch 10A.
- RG 97.81 A shorter PDS must contain:
- (a) a ‘Consumer advisory warning’;
 - (b) a ‘Fees and costs summary’;
 - (c) an ‘Example of annual fees and costs’; and
 - (d) other fees and costs information (which may be incorporated by reference).
- RG 97.82 A shorter PDS must be in the form set out in Sch 10D: see reg 7.9.11O (2). Schedule 10D sets length requirements for the shorter PDS (e.g. eight pages if it is printed on A4 paper), requires specific sections to be included and sets the content for each section.
- RG 97.83 Clause 8 of Sch 10D sets out the requirements for the ‘Fees and other costs’ section of a shorter PDS. Most of the requirements are the same as those in Sch 10.
- RG 97.84 A shorter PDS must also:
- (a) incorporate by reference the fees definitions in cl 209A of Sch 10 and include the address of a link to the definitions maintained on a website (see cl 8(6A) of Sch 10D, as modified by [ASIC Corporations \(Disclosure of Fees and Costs\) Instrument 2019/1070](#));
 - (b) refer to our calculator and any calculator you provide on your website—it must also state that these calculators can be used to calculate the effect of fees and costs on account balances (see cl 8(8) of Sch 10D); and
 - (c) set out a statement about your right to change the amount of fees without the member’s consent, the period of advance notice required, any indexation arrangements that apply, and any change to the fee structure that is dependent on a person’s employment (see cl 8(5) of Sch 10D).
- RG 97.85 You must include detailed information about the superannuation products you offer in section 5 (‘How we invest your money’) of a shorter PDS. This information includes a list of asset classes and a description of the investment return objective. At a minimum, you must provide this information for your generic MySuper product: see cl 7(3) and (4) of Sch 10D.
- RG 97.86 If you do not have a generic MySuper product, but you do have a balanced investment option, the detailed information must be provided for the balanced investment option under which most assets of the superannuation entity are invested: see cl 7(3) and (5) of Sch 10D. If you do not have a balanced investment option, the detailed information must be provided for the investment option under which most assets of the superannuation entity are invested: see cl 7(3) and (6) of Sch 10D.

‘Consumer advisory warning’

- RG 97.87 You must include a ‘Consumer advisory warning’ at the start of the ‘Fees and other costs’ section of the shorter PDS in the same form required in Sch 10: see cl 8(2) of Sch 10D, RG 97.31 and Figure 1.

‘Fees and costs summary’

- RG 97.88 You must include a ‘Fees and costs summary’ in the body of the shorter PDS for each MySuper product or investment option presented in detail in section 5 of the shorter PDS: see cl 8(1) and (3) of Sch 10D, as modified by [ASIC Corporations \(Disclosure of Fees and Costs\) Instrument 2019/1070](#).
- RG 97.89 The layout of the ‘Fees and costs summary’ is set out in cl 8(3) of Sch 10D, as modified by ASIC Corporations (Disclosure of Fees and Costs) Instrument 2019/1070. It is the same as the ‘Fees and costs summary’ in Sch 10 (see Figure 2), apart from there being no preamble text as seen in Figure 2. Instead, you must state that information in the ‘Fees and costs summary’ can be used to compare costs between different superannuation products and state concisely, and in general terms, that fees can be paid directly from the person’s account or deducted from investment returns: see cl 8(6) of Sch 10D, as modified by ASIC Corporations (Disclosure of Fees and Costs) Instrument 2019/1070.
- RG 97.90 You must complete the ‘Fees and costs summary’ in the same way as for a full PDS described in RG 97.27–RG 97.55, apart from some minor differences that are detailed in cl 8(4) of Sch 10D, as modified by ASIC Corporations (Disclosure of Fees and Costs) Instrument 2019/1070.

‘Example of annual fees and costs’

- RG 97.91 You must also include an ‘Example of annual fees and costs’ in the body of the shorter PDS for each MySuper product or investment option presented in detail in section 5 of the shorter PDS: see cl 8(7) of Sch 10D, as modified by ASIC Corporations (Disclosure of Fees and Costs) Instrument 2019/1070. You must complete the ‘Example of annual fees and costs’ in the same way as the full PDS: see RG 97.57–RG 97.64, including Figure 3.

Other fees and costs information

- RG 97.92 You must also provide the fees and costs for each of the MySuper products and investment options offered. These must be provided in accordance with the requirements in Sch 10: see cl 8(10)(a) of Sch 10D. The fees and costs information that must be provided is the ‘Fees and costs summary’, the ‘Additional explanation of fees and costs’ and the ‘Cost of product information’, but not the ‘Example of annual fees and costs’.

- RG 97.93 You can incorporate this other fees and costs information by reference: see cl 8(10)(a) of Sch 10D. For more information on the Sch 10 requirements for superannuation products, see RG 97.27–RG 97.79.
- RG 97.94 You should not include any additional voluntary information in the ‘Fees and costs summary’ or in the ‘Example of annual fees and costs’ in the shorter PDS. Additional voluntary information can, however, be included elsewhere in the ‘Fees and other costs’ section of the shorter PDS, or you may provide more detailed fee information by incorporating it by reference: see cl 8(10)(b) of Sch 10D and reg 7.9.11P. When providing any voluntary information, we encourage you to consider how you can disclose this information in a way that best meets the needs of the types of consumers who invest in your superannuation product.

Costs met from reserves

- RG 97.95 Superannuation trustees may establish reserves for several different purposes, including managing administration, investment and operational risk. These reserves are funded in various ways.
- RG 97.96 A superannuation trustee may meet some portion of the administration fees and costs, investment fees and costs, or transaction costs, in relation to a superannuation product or investment option by debits from reserves. Fees and costs disclosure that includes the cost of a product or investment option that is met from reserves promotes product comparability and helps ensure that the PDS is not misleading.
- RG 97.97 When costs are met by debits from reserves, the amount to be included in the totals for the relevant types of costs is limited. This is to ensure that no double counting arises in relation to amounts that have been credited to a reserve that themselves already count towards the costs required to be disclosed.
- RG 97.98 The relevant amounts of the costs debited to reserves are those that, in a period, are in excess of amounts credited to reserves in that period that are also, relevantly, administration fees or costs, investment fees and costs, or transaction costs: see the definitions of ‘administration fees and costs’ and ‘investment fees and costs’ in cl 101 of Sch 10 and the definition of ‘transaction costs’ in cl 103 of Sch 10.
- RG 97.99 For example, as shown in Figure 6, the costs component of the administrations fees and costs to be disclosed in a PDS is determined for the previous financial year: see cl 104 of Sch 10. In the example, in the previous financial year, a superannuation trustee charged \$1 million as total member fees, and credited these fees into a reserve. Over that previous financial year, the trustee met some portion of the administration-related costs in relation to the superannuation product or investment option by debiting \$1.5 million out of the reserve. Therefore, the amount of the costs that were met by being

debited from the reserve that should be counted towards the total of administration fees and costs is the excess (i.e. \$500,000).

Figure 6: Example of administration fees and costs met from reserves

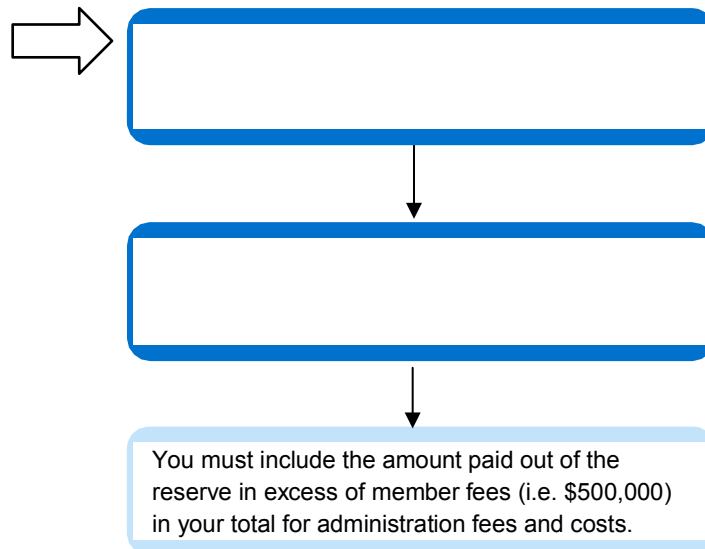

Note: The information in this figure is described in RG 97.99 (accessible version).

Calculating costs for superannuation products

- RG 97.100 The cost components included in administration fees and costs, and in investment fees and costs (including indirect costs: see RG 97.271–RG 97.282), are generally determined based on the costs incurred in the previous financial year. Exceptions apply if the superannuation product or investment option was not previously offered for a full financial year or if the option was not offered at all during the previous financial year. In this situation, an estimate of costs must be disclosed: see Table 4.
- RG 97.101 On the other hand, fees charged by you to members directly or otherwise to the superannuation entity as part of administration fees and costs, or investment fees and costs, are always disclosed based on what currently applies.
- RG 97.102 We recognise that to calculate costs (under cl 104(1)(a) and (b) of Sch 10), an estimate may be required if information about costs incurred towards the end of the previous financial year is not available. Clauses 104(1)(c) and (d) of Sch 10 both require you to make a reasonable estimate of the costs for the current financial year. When you use an estimate, we expect you to specify this in the ‘Additional explanation of fees and costs’. For more information on making reasonable estimates, see RG 97.388–RG 97.397. For information on the calculation of performance fees within investment fees and costs, see RG 97.374–RG 97.380.

Table 4: Calculating costs for superannuation products and investment options

Timing of offer	What costs must be based on	Reference in Sch 10
The product or option was offered for the entire previous financial year.	Costs must be based on the costs for that previous financial year.	Clause 104(1)(a)
The product or option was offered from at least 11 months before the end of the previous financial year, but for less than a full financial year.	Costs must be based on the costs for that period, adjusted to reflect a 12-month period.	Clause 104(1)(b)
The product or option was <i>not</i> offered from at least 11 months before the end of the previous financial year, and was <i>not</i> first offered in the current financial year.	Costs must be based on a reasonable estimate of the costs for the 12-month period derived from costs to date in the current financial year.	Clause 104(1)(c)
The product or option was first offered in the current financial year.	Costs must be based on a reasonable estimate of the costs for that part of the current financial year when the product or option was offered, adjusted to reflect a 12-month period.	Clause 104(1)(d)

Disclosure of fees and costs for insurance

- RG 97.103 You must disclose the fees and costs relating to insurance coverage in the insurance section of the PDS: see cls 201 and 209(ca) of Sch 10. The disclosure should include information on:
- insurance premiums and how they are calculated, including factors that affect the premiums (e.g. an adviser commission) and how these factors affect the member, the amount of the premiums and whether the member will receive a rebate;
 - the imposition of any loading factors, such as occupational-based loading or any additional amount charged because the member chooses to pay their premiums monthly rather than as an annual upfront payment;
 - any policy or administration fee you charge in addition to the amounts to cover the premium payable to the insurer; and
 - whether the superannuation entity or the member will meet any costs of stamp duty and how stamp duty is calculated if the member is liable.
- RG 97.104 To allow members to more easily compare insurance premiums offered across different superannuation products, and to ensure that your PDS is worded and presented in a clear, concise and effective manner, the information should:
- be presented in a table; and
 - relate to the ages of members.
- RG 97.105 For shorter PDSs, Sch 10D requires that specific disclosures about insurance are included: see cl 10(2)(c)–(d), (3)(b) and (4)(b) of Sch 10D.

C Superannuation products: Periodic statements

Key points

This section provides guidance on the costs and fees disclosure requirements for periodic statements for superannuation products.

Periodic statements provide each member with information about their account for the relevant reporting period. Periodic statements are generally provided annually and also after the member ceases to hold the superannuation product.

A periodic statement must contain:

- a 'Transaction list';
- the amount of 'Fees deducted directly from your account' and the approximate amount of 'Fees and costs deducted from your investment';
- the total of all fees and costs disclosed in the periodic statement ('Total fees and costs you paid'); and
- 'Additional explanation of fees and costs'.

This section also provides guidance on how the periodic statement requirements apply to defined benefit members: see RG 97.135–RG 97.137.

Requirement to provide periodic statements

- RG 97.106 You must give members who acquire superannuation products as a retail client a periodic statement for a period of no more than 12 months (reporting period) during which the member holds the product: see s1017D(2). You must give a periodic statement as soon as practicable after the end of the reporting period and, in any event, within six months after the end of the reporting period to which it relates: see s1017D(3).
- RG 97.107 If a member ceases to hold the superannuation product during the reporting period, you must provide a periodic statement for the start of the reporting period until the time of exit. You must give this exit statement as soon as you become aware that the member has ceased to hold the product. In particular, you must make reasonable efforts to give the exit statement within one month after becoming aware that the member has ceased to hold the product: see s1017D(3A), as inserted by Pt 12 of Sch 10A to the Corporations Regulations.
- RG 97.108 Most members will be considered to be a retail client when acquiring superannuation products: see s761G(6).
- RG 97.109 In periodic statements, the fees and costs (including indirect costs) are to be determined over the period to which the periodic statement relates: see cl 104B of Sch 10.

Fees and costs disclosure requirements for periodic statements

- RG 97.110 A periodic statement must give the member the information that you reasonably believe the member needs to understand their investment: see s1017D(4).
- RG 97.111 You must include the mandatory information about fees and costs and member benefits. Detailed content requirements for fees and costs disclosure in periodic statements for superannuation products are set out in s1017D(5) and 1017DA of the Corporations Act, and in Pt 7.9 of the Corporations Regulations, including Subdivs 4C.3 and 5.2, and Divs 5AA and 8.
- RG 97.112 In providing details of the amounts of the member's withdrawal benefit or other significant benefits (including disability benefits), a periodic statement must also include details of any deductions for fees, charges or expenses that have or might be made: see regs 7.9.19(g) and 7.9.20(1)(kb).
- RG 97.113 Under the fees and costs disclosure requirements, a periodic statement must contain:
- (a) a 'Transaction list';
 - (b) the amount of 'Fees deducted directly from your account' and the approximate amount of 'Fees and costs deducted from your investment';
 - (c) the total of all fees and costs disclosed in the periodic statement ('Total fees and costs you paid'); and
 - (d) 'Additional explanation of fees and costs'.

'Transaction list'

- RG 97.114 Section 1017D(5)(c) requires you to include a list of transactions relating to the superannuation product during the reporting period in a periodic statement. The 'Transaction list' must include a brief description of each transaction in relation to the superannuation product during the reporting period: see reg 7.9.60B(2).
- RG 97.115 You only need to itemise those fees and costs shown in the 'Fees and costs summary' in the 'Transaction list': see reg 7.9.60B(6). You must describe those fees and costs using the terms used in the 'Fees and costs summary': see reg 7.9.60B(7) and Figure 2. If a fee or cost is not charged, you do not need to include it in the 'Transaction list'.
- RG 97.116 We expect that you only include fees and costs in the 'Transaction list' that are deducted directly from the member's account. The impact of other fees and costs is shown in the 'Fees and costs deducted from your investment': see RG 97.128–RG 97.130.
- RG 97.117 You may describe transactions of the same kind (other than contributions) in a single item in the 'Transaction list' if it is practicable to do so and the

items are described together on a consistent basis in the periodic statement: see reg 7.9.60B(5). You must assess whether a particular grouping of transactions will achieve clear disclosure of the relevant transactions.

RG 97.118 If you decide to group fees in a single line item, this should not obscure the true frequency or amount of a recurring fee. Using a subtotal would help meet this objective—for example, ‘a weekly administration fee of \$1 for 52 weeks (total \$52)’. In some cases, it may not be appropriate to use an annual grouping. If there is a fee increase during the reporting period, this should be set out clearly—for example, ‘a weekly administration fee of \$1 for 26 weeks until 31 December 2019 (total \$26) and a weekly administration fee of \$1.50 for 26 weeks until 30 June 2020 (total \$39)’.

RG 97.119 You must include the amounts paid by the member of the superannuation product during the period: see regs 7.9.75(1)(a) and 7.9.20(1)(d).

Note: Regulation 7.9.75(1)(b) has been omitted by [ASIC Corporations \(Disclosure of Fees and Costs\) Instrument 2019/1070](#).

RG 97.120 An amount is considered to be paid by a member in respect of a superannuation product if:

- (a) the member has paid an amount in respect of the product;
- (b) an amount has been deducted from a payment made by or to the member;
- (c) the member has paid an amount or an amount has been deducted or debited as a fee, expense or charge in relation to the superannuation product; or
- (d) an amount is held on the member’s behalf under the financial product (see reg 7.9.75(2)).

Impact of tax on disclosed transactions

RG 97.121 You must include, if applicable, goods and services tax (GST), stamp duty and income tax (after deductions have been taken into account) in transaction amounts: see reg 7.9.60B(3). We consider that GST should be included less reduced input tax credits.

RG 97.122 We consider that if GST or stamp duty are not disclosed as part of the transaction amount, they should be reported as separate transactions.

RG 97.123 If the payment of a fee or cost results in the superannuation entity becoming entitled to a tax deduction and you pass that tax deduction on to a member, the periodic statement must show two transactions:

- (a) one for the full amount charged; and
- (b) one for the tax benefit that was passed on to the member (see cl 301(4) of Sch 10).

- RG 97.124 When a transaction creates an income tax liability, or a tax deduction is given to the member, we expect you to show this transaction separately and include an explanation of the basis for the transaction and its relationship with other transactions.

Example

The receipt of a superannuation contribution by a member does not, of itself, involve income tax at the time it is received. Reduction of the member's account balance to reflect income tax you pay for the contribution is another transaction that may occur after the superannuation entity has received its income tax assessment. We expect you to explain in the periodic statement how the income tax transaction amount is calculated.

In this case, there are two transactions that you must report separately:

- the receipt of the contribution; and
- any reduction of the member's account balance due to the liability for the superannuation entity's income tax.

'Fees deducted directly from your account' and 'Fees and costs deducted from your investment'

- RG 97.125 You must include the details set out in Pt 3 of Sch 10 in the periodic statement: see regs 7.9.16O and 7.9.75(1)(e). These requirements are set out at RG 97.126–RG 97.134.
- RG 97.126 Clause 301(1) of Sch 10 requires periodic statements for MySuper products or investment options to include certain text (with the appropriate amounts in dollars) after the 'Transaction list' under the heading 'Fees and costs summary'. Figure 7 shows the text required by cl 301(1) of Sch 10. You must show each of these amounts as a single total amount in dollars: see cl 301(3) of Sch 10.

Figure 7: Text required after the 'Transaction list'

Fees deducted directly from your account

\$[]

This amount has been deducted directly from your account (reflected in the transactions listed on this statement).

Fees and costs deducted from your investment

\$[]

This approximate amount has been deducted from your investment and covers amounts that have reduced the return on your investment and that are not reflected as transactions listed on this statement or in the Additional explanation of fees and costs.

- RG 97.127 The amount to be shown as the ‘Fees deducted directly from your account’ is the total amount of fees deducted on the ‘Transaction list’ in the periodic statement: see cl 301(2)(a) of Sch 10.
- RG 97.128 The amount shown as the ‘Fees and costs deducted from your investment’ is an apportioned amount: see cl 301(2)(b) of Sch 10. This is the amount of fees and costs for the superannuation product or investment option that are attributed to the particular member, and that are not:
- (a) excluded transactional or operational costs (see RG 97.342–RG 97.346);
 - (b) reflected in the ‘Transaction list’ (see RG 97.114–RG 97.124); and
 - (c) reflected in the ‘Additional explanation of fees and costs’ in the periodic statement (see RG 97.133–RG 97.134).
- RG 97.129 The amount disclosed in ‘Fees and costs deducted from your investment’ must include the buy–sell spread charged to a member.
- RG 97.130 If the superannuation product is subject to tax and a reduced fee or cost is shown in the statement because of the benefit of an income tax deduction, you must include the part of the cost that reduced the disclosed fee or cost in the ‘Fees and costs deducted from your investment’: see cl 301(4) of Sch 10.

‘Total fees and costs you paid’

- RG 97.131 Clause 302(1) of Sch 10 requires a periodic statement to include certain text (with the appropriate amount in dollars) either after ‘Fees and costs deducted from your investment’ or in a summary part of the periodic statement. Figure 8 shows the text required by cl 302(1) of Sch 10.

Figure 8: Text required for ‘Total fees and costs you paid’

TOTAL FEES AND COSTS YOU PAID

[\$]

This approximate amount includes all the fees and costs that affected your investment during the period.

- RG 97.132 The amount to be inserted is the total of all fees and costs disclosed in the periodic statement, including any fees detailed in cl 303(1)(a) of Sch 10: see cl 302(2) of Sch 10.

‘Additional explanation of fees and costs’

- RG 97.133 Clause 303(1) of Sch 10 requires you to include the following information in a periodic statement for superannuation products, under the heading ‘Additional explanation of fees and costs’, if that information has not been included in another part of the periodic statement:
- (a) details of any activity fees, advice fees and insurance fees that were incurred by the member during the period;

- (b) if the superannuation product is subject to tax, whether the benefit of any tax deduction has been passed on to the member in the form of a reduced fee or cost; and
- (c) a statement in relation to the operation of the fee capping regime for products with an account balance of less than \$6,000.

RG 97.134 If details of activity fees, advice fees and insurance fees are shown in the 'Additional explanation of fees and costs', these must include the relevant amounts incurred. This ensures that these fees are included in 'Total fees and costs you paid', so that all relevant fees and costs are captured in the periodic statement.

Periodic statements for defined benefit members

RG 97.135 We recognise that some common types of transactions may not be relevant to defined benefit members, given that often the obligation to make contributions and pay fees and costs may be the responsibility of those members' employers. However, we expect that in periodic statements for defined benefit members you will, at a minimum, report transactions for particular defined benefit members who receive:

- (a) contributions; and
- (b) benefits rolled over or transferred into the superannuation entity (see reg 7.9.20(1)(a) and (b)).

RG 97.136 We do not expect you to report in periodic statements for defined benefit members:

- (a) any bulk and generalised employer contributions that are made to maintain the general solvency of the superannuation entity and that do not specifically relate to individual members; and
- (b) any transactions that are made at the superannuation entity level that do not relate to a particular defined benefit member.

RG 97.137 If there are no fees and costs that affect the defined benefit member's entitlement, the 'Fees deducted directly from your account', 'Fees and costs deducted from your investment' and the 'Total fees and costs you paid' in the periodic statement, required by cls 301(1) and 302(1) of Sch 10, can be shown as zero.

D Managed investment products and notified foreign passport fund products: PDSs

Key points

This section explains the fees and costs disclosure requirements for managed investment products and notified foreign passport fund products for PDSs.

Although there are some similarities, the fees and costs disclosure requirements for these products are different from those for superannuation products (e.g. managed investment products charge management fees and costs, instead of investment fees and costs and administration fees and costs).

You will need to prepare the following information for any managed investment product or notified foreign passport fund product requiring a full PDS:

- a 'Consumer advisory warning';
- a 'Fees and costs summary';
- an 'Example of annual fees and costs';
- 'Cost of product information'; and
- 'Additional explanation of fees and costs' (see RG 97.138–RG 97.190).

A shorter PDS must include:

- a 'Consumer advisory warning';
- a 'Fees and costs summary';
- an 'Example of annual fees and costs'; and
- other fees and costs information (see RG 97.191–RG 97.209).

This section also provides guidance on calculating costs for managed investment products and notified foreign passport fund products: see RG 97.210–RG 97.213.

Note: You should also refer to Sections G and H for further guidance on particular fees and costs concepts, and how to calculate and present fees and costs. In the guidance below, we have included cross-references to relevant parts of those sections.

Fees and costs disclosure requirements for full PDSs

- RG 97.138 Most issuers of managed investment products and notified foreign passport fund products must prepare full PDSs. Registered schemes that are simple managed investment schemes must generally use the shorter PDS regime: see RG 97.191–RG 97.209. Australian passport funds cannot be simple managed investment schemes: see reg 1.0.02 for the definition of a simple managed investment scheme.

- RG 97.139 In preparing a full PDS for a managed investment product or notified foreign passport fund product, you must include a single ‘Fees and other costs’ section comprising:
- (a) a ‘Consumer advisory warning’;
 - (b) a ‘Fees and costs summary’;
 - (c) an ‘Example of annual fees and costs’;
 - (d) ‘Cost of product information’; and
 - (e) ‘Additional explanation of fees and costs’ (see reg 7.9.16N).

‘Consumer advisory warning’

- RG 97.140 You must include a ‘Consumer advisory warning’ in a full PDS for managed investment products and notified foreign passport fund products: see reg 7.9.16N(2)(c). The only circumstance when you are not required to include the ‘Consumer advisory warning’ is when the structure of the product means there is no fund from which fees and costs are paid. This reflects that, for these types of products, including a ‘Consumer advisory warning’ would confuse consumers.
- RG 97.141 You must include the ‘Consumer advisory warning’ at the beginning of the ‘Fees and other costs’ section of the PDS: see cl 222(2) of Sch 10. The content is set out in cl 221(2) of Sch 10. You must not make any changes or additions, other than to change the reference from ‘account’ to ‘investment’, if appropriate: see cl 221(3) of Sch 10. Figure 9 shows the text of the ‘Consumer advisory warning’.

Figure 9: ‘Consumer advisory warning’ for managed investment products and notified foreign passport fund products

DID YOU KNOW?

Small differences in both investment performance and fees and costs can have a substantial impact on your long-term returns.

For example, total annual fees and costs of 2% of your account balance rather than 1% could reduce your final return by up to 20% over a 30-year period (for example, reduce it from \$100,000 to \$80,000).

You should consider whether features such as superior investment performance or the provision of better member services justify higher fees and costs.

You may be able to negotiate to pay lower fees. Ask the fund or your financial adviser.

TO FIND OUT MORE

If you would like to find out more, or see the impact of the fees based on your own circumstances, the **Australian Securities and Investments Commission (ASIC)** MoneySmart website (www.moneysmart.gov.au) has a managed funds fee calculator to help you check out different fee options.

‘Fees and costs summary’

- RG 97.142 You must include a ‘Fees and costs summary’ in a full PDS for a managed investment product or notified foreign passport fund product: see reg 7.9.16N(2)(a).
- RG 97.143 There are two types of ‘Fees and costs summary’, depending on whether the relevant managed investment product or notified foreign passport fund product has a single fee structure or a multiple fee structure. The content of the two types of ‘Fees and costs summary’ is set out in cls 202 and 202A of Sch 10. Each type is a table separated into:
- (a) ‘Ongoing annual fees and costs’; and
 - (b) ‘Member activity related fees and costs’.
- RG 97.144 The items in the ‘Fees and costs summary’ show the significant fees and costs that will be charged to members.
- RG 97.145 Figure 10 shows the ‘Fees and costs summary’ that you must complete for a managed investment product or notified foreign passport fund product with a single fee structure.

Figure 10: ‘Fees and costs summary’ for managed investment product or notified foreign passport fund product—Single fee structure**Fees and other costs**

This section shows fees and other costs that you may be charged. These fees and costs may be deducted from your money, from the returns on your investment or from the assets of the managed investment scheme as a whole.

Taxes are set out in another part of this document.

You should read all the information about fees and costs because it is important to understand their impact on your investment.

[If relevant] Fees and costs for particular investment options are set out on page *[insert page number]*.

Fees and costs summary

<i>[Name of collective investment product]</i>		
Type of fee or cost	Amount	How and when paid
Ongoing annual fees and costs		
<i>Management fees and costs</i> The fees and costs for managing your investment ²		
<i>Performance fees</i> Amounts deducted from your investment in relation to the performance of the product		

<i>Transaction costs</i> The costs incurred by the scheme when buying or selling assets		
Member activity related fees and costs (fees for services or when your money moves in or out of the product)¹		
<i>Establishment fee</i> The fee to open your investment		
<i>Contribution fee²</i> The fee on each amount contributed to your investment		
<i>Buy–sell spread</i> An amount deducted from your investment representing costs incurred in transactions by the scheme		
<i>Withdrawal fee²</i> The fee on each amount you take out of your investment		
<i>Exit fee²</i> The fee to close your investment		
<i>Switching fee</i> The fee for changing investment options		

1. [If there are other service fees, such as advice or special request fees, include a cross-reference to the “Additional explanation of fees and costs”.]
2. This fee includes an amount payable to an adviser. (See Division 4, “Adviser remuneration” under the heading “Additional explanation of fees and costs”.)

RG 97.146 If you are completing a ‘Fees and costs summary’ for a managed investment product or notified foreign passport fund product with a multiple fee structure, we expect you to explain the fee structure in the preamble, and then set out the options in the ‘Amount’ column. The following example is text that could be included in the preamble for a managed investment product or notified foreign passport fund product with two different fee payment options.

Example of additional preamble text

You have two different fee payment options:

- (a) to pay contribution fees upfront, at the time when you make each investment into the managed investment scheme; or
- (b) to pay contribution fees later (for example, on the termination of your investment or by way of other increased fees).

Note: You may pay more in total fees if you choose to pay contribution fees later.

RG 97.147 In this example, the headings in the ‘Amount’ column would be ‘Option to pay contribution fees upfront’ and ‘Option to pay contribution fees later’.

RG 97.148 For more information on how to fill in the ‘Fees and costs summary’, see RG 97.164 and RG 97.352–RG 97.361. For more information on the line items, see RG 97.149–RG 97.163.

Explanation of ongoing annual fees and costs

RG 97.149 As shown in Figure 10, the ‘Ongoing annual fees and costs’ comprise:

- (a) management fees and costs (see RG 97.150–RG 97.154);
- (b) performance fees (see RG 97.155–RG 97.158); and
- (c) transaction costs (see RG 97.159–RG 97.161).

Management fees and costs

RG 97.150 Management fees and costs are defined in cl 102 of Sch 10. They include:

- (a) amounts payable for administering the managed investment scheme;
- (b) amounts paid for investing in the assets of the managed investment scheme; and
- (c) other expenses and reimbursements in relation to the managed investment scheme.

RG 97.151 Management fees and costs also include indirect costs: see cl 102(1)(h) of Sch 10. For information on indirect costs, see RG 97.271–RG 97.282.

RG 97.152 A number of items are excluded from the definition of management fees and costs: see cl 102(2) of Sch 10. These are:

- (a) costs that are otherwise charged as another type of fee, such as a contribution fee;
- (b) transaction costs other than those costs that relate to derivative financial products under cl 101A(3) of Sch 10 (for more information, see RG 97.331–RG 97.341);
- (c) excluded transactional and operational costs (for more information, see RG 97.342–RG 97.346); and
- (d) costs related to a specific asset or activity to produce income that a member would incur if they invested directly in the asset.

RG 97.153 However, costs relating to a security or interest in an interposed vehicle or derivative financial product (within the meaning of cl 101A(3A) of Sch 10) must not be excluded from management fees and costs, even if the investor would incur these costs if they invested directly in the asset. This means, for example, that you cannot exclude the costs incurred in relation to an investment in an underlying managed investment scheme that would be considered to be an interposed vehicle (see RG 97.300–RG 97.330) from management fees and costs, even though the investor would incur those costs if they invested directly in the relevant managed investment scheme.

- RG 97.154 Examples of the types of things that would be included in management fees and costs are:
- (a) fees charged for administering, operating and managing the managed investment scheme (including start-up and initial one-off fees or costs);
 - (b) custodian and custody fees;
 - (c) amounts payable for investing the assets of the managed investment scheme, including fees paid to asset consultants and valuation costs;
 - (d) audit costs;
 - (e) overheads, including accommodation, information technology costs and internal staff costs in member services teams (including costs associated with member communication) and investment teams;
 - (f) costs of professional indemnity insurance, directors' and officers' insurance, and other insurance;
 - (g) product development costs; and
 - (h) investment fees and costs, and management fees and costs, charged by an interposed vehicle.

Performance fees

- RG 97.155 Performance fees are defined in cl 101C of Sch 10. For more information, see RG 97.374–RG 97.382.
- RG 97.156 Performance fees that are '0' or positive amounts must be disclosed in the 'Fees and costs summary'. If you do not charge a performance fee, it must be disclosed as 'nil' or '0'.
- RG 97.157 If performance fees are negative, their amount must not be disclosed in the 'Fees and costs summary'. Instead, insert into the 'Amount' column the text (see cl 204B of Sch 10):
- 'See Additional explanation of fees and costs.'
- RG 97.158 The 'Additional explanation of fees and costs' is where the negative performance fee amount must be provided: see cl 209(b)(iv) of Sch 10. You must also include details, including the amount, for performance fees chargeable by the responsible entity or operator, the method for calculating the total performance fees, and the calculated average performance fees for each product or investment option or interposed vehicle or part: see cl 209(b)(ii)–(v) of Sch 10.

Transaction costs

- RG 97.159 Transaction costs are defined in cl 103(1) of Sch 10. For further information, see RG 97.331–RG 97.341.

- RG 97.160 In the 'Fees and costs summary', transaction costs are shown net of amounts recovered by the buy–sell spread charged by the responsible entity or operator: see cl 204A of Sch 10. Transaction costs are shown in this way so that members can better understand the costs that may affect their investment, as some transaction costs will be paid for by members who are charged the buy–sell spread when they enter or exit the managed investment scheme or notified foreign passport fund product.
- RG 97.161 It is important that you do not incorrectly categorise a cost that should be included in management fees and costs as a transaction cost. Incorrect categorisation of costs could make your PDS misleading.

Explanation of 'Member activity related fees and costs'

- RG 97.162 These fees are defined in cl 101 of Sch 10. They are also described in the standard text in the 'Type of fee or cost' column in the 'Fees and costs summary'.
- RG 97.163 If there are other service fees, such as advice fees or special request fees, the line item for 'Member activity related fees and costs' must include a cross-reference to the 'Additional explanation of fees and costs'.

How to fill in the 'Fees and costs summary'

- RG 97.164 You must ensure that the fee information for each investment option offered by the managed investment product is either set out in the 'Fees and costs summary' or that the 'Fees and costs summary' contains a cross-reference to another section of the PDS that contains the relevant information: see cl 205 of Sch 10.
- RG 97.165 For further information on how to fill in the 'Fees and costs summary', see RG 97.352–RG 97.361.

'Example of annual fees and costs'

- RG 97.166 You must include an 'Example of annual fees and costs' in the 'Fees and other costs' section of a full PDS for a managed investment product or notified foreign passport fund product, following the 'Fees and costs summary': see reg 7.9.16N(2)(b) and cl 210(c) of Sch 10.
- RG 97.167 Issuers have some flexibility as to the form of the 'Example of annual fees and costs' used: see RG 97.169–RG 97.179. However, when the product and its fees and costs arrangements can be disclosed using the format set out in cl 212 of Sch 10, you must use that format without any alterations.
- RG 97.168 Figure 11 shows the 'Example of annual fees and costs' that you must complete if your product can be disclosed using the format set out in cl 212 of Sch 10.

- RG 97.169 When the format in cl 212 of Sch 10 does not suit the product, you can use an alternative format that provides a clear example of the application of the fees and costs for the product. You must make the minimum adaptations necessary to the required format and content of the ‘Example of annual fees and costs’. You must also ensure that the alternative format and content is not misleading.
- RG 97.170 An example of when you may need to adapt the ‘Example of annual fees and costs’ is an agricultural scheme when, during a typical ongoing year, low fees apply but other fees (such as harvest fees) may apply at the end of the managed investment scheme. In these circumstances, we expect the adapted ‘Example of annual fees and costs’ to clearly refer to the fact that future fees may apply in addition to the low fees that apply for a typical ongoing year.
- RG 97.171 Another example would be when start-up or initial one-off fees apply. As these are not typical ongoing fees, we would expect the adapted ‘Example of annual fees and costs’ to explain these start-up and initial one-off fees to avoid the possibility that consumers may misunderstand the fee structure of the product.

Figure 11: ‘Example of annual fees and costs’ for a balanced investment option or other investment option

Example of annual fees and costs for a balanced investment option or other investment option

This table gives an example of how the ongoing annual fees and costs in the balanced investment option for this product can affect your investment over a 1-year period. You should use this table to compare this product with other products offered by managed investment schemes.

EXAMPLE— <i>[insert name of balanced investment option or other investment option required by subclause 220(2)]</i>		BALANCE OF \$50,000 WITH A CONTRIBUTION OF \$5,000 DURING YEAR
Contribution fees	[]	For every additional \$5,000 you put in, you will be charged between \$0 and \$[]
PLUS Management fees and costs	[]	And , for every \$50,000 you have in the <i>[insert name of balanced investment option or other investment option required by subclause 220(2)]</i> you will be charged \$[] each year
PLUS Performance fees	[]	And , you will be charged \$[] in performance fees each year
PLUS Transaction costs	[]	And , you will be charged \$[] in transaction costs.
EQUALS Cost of <i>[insert name of balanced investment option or other investment option required by subclause 220(2)]</i>		If you had an investment of \$50,000 at the beginning of the year and you put in an additional \$5,000 during that year, you would be charged fees of from: \$[] to \$[]* What it costs you will depend on the investment option you choose and the fees you negotiate.

* Additional fees may apply:

Establishment fee—\$[]

And, if you leave the managed investment scheme early, you may also be charged **exit fees** of between 0 and []% of your total account balance (between \$0 and \$[] for every \$50,000 you withdraw).

How to fill in the ‘Example of annual fees and costs’

- RG 97.172 We expect you to base the ‘Example of annual fees and costs’ on your balanced investment option. If you do not offer a balanced investment option, you should base the example on the default investment option. If you do not offer a default investment option, base the example on the investment option under which most assets of the managed investment scheme are invested: see cl 220(2) of Sch 10.
- RG 97.173 We expect you to base the fees and costs on typical ongoing fees that apply to the investment option. The example should not be based on ‘honeymoon’ rates and must be consistent with the statement for an existing member having the stated balance and level of contribution each year: see cl 214 of Sch 10.
- RG 97.174 If the minimum balance required to invest in the managed investment product is greater than \$50,000, the ‘Example of annual fees and costs’ must be based on an amount that is the lowest multiple of \$50,000 that exceeds the minimum balance: see cl 215 of Sch 10.
- RG 97.175 You must also show the effect of contribution fees, exit fees and withdrawal fees: see cls 216–217 and 219 of Sch 10. If the product is paid for by a single lump sum amount or does not allow additional contributions, then the references to contributions or contribution fees can be removed: see cl 217(2) of Sch 10.
- RG 97.176 If there is a range in the amount of management fees and costs, performance fees or transaction costs that may be charged, the example must use the highest fees and costs in the range: see cl 218A(2) and (5) of Sch 10. Also, the calculation must not take into account contributions that may be made during the year: see notes to cl 218A(1), (3A) and (4) of Sch 10.
- RG 97.177 You must show any dollar-based management fees and costs that are deducted directly from the member’s account separately in the management fees and costs line item: see cl 218A(3) of Sch 10.
- RG 97.178 If the performance fee is negative, you must insert a ‘0’ figure in the performance fees line item: see cl 218A(3B). If the performance fee is a positive figure or nil, then the figure must be inserted in the example.
- RG 97.179 We encourage you to provide calculators or other tools elsewhere, on your website, so that members can calculate the fees they will be charged for the investment option using a balance other than \$50,000.

‘Cost of product information’

- RG 97.180 You must also include ‘Cost of product information’ for each investment option offered. As the ‘Example of annual fees and costs’ is only provided for one investment option, the ‘Cost of product information’ is designed to

give consumers an abbreviated example of how fees and costs can affect their investment if they choose to invest in one of the other investment options that are offered in your PDS. This information must be included in the ‘Fees and other costs’ section of a full PDS, following the ‘Example of annual fees and costs’: see cl 220B(1)(a) of Sch 10.

- RG 97.181 You must calculate the ‘Cost of product information’ using the same method used to calculate the ‘Example of annual fees and costs’ in Div 6 of Sch 10: see cl 220B(1)(d) of Sch 10.
- RG 97.182 You do not need to provide ‘Cost of product information’ when a PDS relates only to one investment option and an ‘Example of annual fees and costs’ has been included for that investment option: see cl 220B(2) of Sch 10.
- RG 97.183 Figure 12 shows the text and heading that you must include immediately before the presentation of the first ‘Cost of product information’.

Figure 12: Preamble for the ‘Cost of product information’ for managed investment products or notified foreign passport fund products

Cost of product information for 1 year

The cost of product gives a summary calculation about how ongoing annual fees and costs can affect your investment over a 1-year period for all investment options. It is calculated in the manner shown in the Example of annual fees and costs.

The cost of product assumes a balance of \$50,000 at the beginning of the year with a contribution of \$5,000 during the year. (Additional fees such as an establishment fee or an exit fee may apply: refer to the Fees and costs summary for the relevant option.)

You should use this figure to help compare this product with other products offered by managed investment schemes.

- RG 97.184 Figure 13 shows the form you must use when setting out the ‘Cost of product information’.

Figure 13: Form for ‘Cost of product information’ for managed investment products or notified foreign passport fund products

<i>[Insert name of investment option]</i>	Cost of product
	\$[]

‘Additional explanation of fees and costs’

- RG 97.185 You must include an ‘Additional explanation of fees and costs’ in a full PDS for a managed investment product or notified foreign passport fund product: see reg 7.9.16N(2)(a). You must include all the information listed in cl 209

of Sch 10, to the extent that information is relevant to the product. This includes information on:

- (a) performance fees (for more information, see RG 97.347–RG 97.350); and
- (b) transaction costs (for more information, see RG 97.331–RG 97.341).

RG 97.186 If the managed investment product or notified foreign passport fund product is subject to tax, you must:

- (a) include a cross-reference to the tax section of the PDS (see cl 209(c) of Sch 10); and
- (b) state whether the benefit of any tax deduction is passed on to the member in the form of a reduced fee or cost (see cl 209(d) of Sch 10).

RG 97.187 You must also include relevant information about your right to change fees and the period of advance notice required to do so: see cl 209(k) of Sch 10.

RG 97.188 If you have instituted a flexible charging structure, the ‘Additional explanation of fees and costs’ must include, for each applicable fee:

- (a) any maximum, and when it would apply; and
- (b) any waiver, and when it would apply (see cl 209(l) of Sch 10).

Note: We consider that a waiver relates to any amount by which the fees and costs disclosed in the ‘Fees and costs summary’ may be reduced (including through a rebate).

RG 97.189 We consider the requirement in RG 97.188 applies in relation to fees that are shown as part of a line item in the ‘Fees and costs summary’ or are mentioned in the footnotes.

RG 97.190 We expect you to consider what other information is appropriate to include in the ‘Additional explanation of fees and costs’. You should ensure that any other information is shown in a clear, concise and effective manner, as required by s1013C(3). When providing any other information, we encourage you to consider how you can disclose this information in a way that best meets the needs of the types of consumers who invest in your product.

Fees and costs disclosure requirements for shorter PDSs

RG 97.191 As set out at RG 97.138, registered managed investment schemes that are simple managed investment schemes must prepare a shorter PDS in most circumstances: see reg 7.9.11S. The shorter PDS regime for simple managed investment schemes is facilitated by regulations that modify the Corporations Act: see Pt 5C of Sch 10A.

RG 97.192 Simple managed investment schemes are registered managed investment schemes that have predominantly very liquid assets. They must have at least 80% of their assets in a bank account where funds can be withdrawn within

three months or in arrangements where the responsible entity can reasonably expect to realise the investment at market value within 10 days: see reg 1.0.02.

- RG 97.193 As noted at RG 97.138, Australian passport funds are not eligible to be simple managed investment schemes: see reg 1.0.02.
- RG 97.194 See [\[CO 12/749\]](#) for details of other managed investment schemes (such as multi-funds and hedge funds) that may be unable to use the shorter PDS regime.
- RG 97.195 A shorter PDS must contain:
- (a) a ‘Consumer advisory warning’;
 - (b) a ‘Fees and costs summary’;
 - (c) an ‘Example of annual fees and costs’; and
 - (d) other fees and costs information (which may be incorporated by reference).
- RG 97.196 A shorter PDS must be in the form set out in Sch 10E: see reg 7.9.11W(2). Schedule 10E sets length requirements for the shorter PDS (e.g. eight pages if it is printed on A4 paper), requires specific sections to be included and sets the content for each section.
- RG 97.197 Clause 8 of Sch 10E sets out the requirements for the ‘Fees and other costs’ section of the shorter PDS. Most of the requirements are the same as those in Sch 10.
- RG 97.198 A shorter PDS must:
- (a) refer to our calculator and any calculator you provide on your website—it must also state that these calculators can be used to calculate the effect of fees and costs on account balances (see cl 8(8) of Sch 10E); and
 - (b) set out a statement about your right to change the amount of fees without the member’s consent, any indexation arrangements that apply and the notice period required (see cl 8(5) of Sch 10E).
- RG 97.199 You must include detailed information about investment options you offer in section 5 (‘How we invest your money’) of a shorter PDS. This information includes a list of asset classes and a description of the investment return objective. At a minimum, you must provide this information for the simple managed investment scheme’s balanced investment option.
- RG 97.200 If you do not offer a balanced investment option, you must provide detailed information for the investment option under which the simple managed investment scheme has the most funds invested. If the scheme has never previously been offered to investors, or does not have an investment option under which most funds are invested, you must provide detailed information for the investment option that you reasonably believe has the least volatile underlying assets: see cl 7(3)–(5) of Sch 10E.

‘Consumer advisory warning’

- RG 97.201 You must include a ‘Consumer advisory warning’ at the start of the ‘Fees and other costs’ section of the shorter PDS in the same form as required in Sch 10: see cl 8(2) of Sch 10E, RG 97.140–RG 97.141 and Figure 9.

‘Fees and costs summary’

- RG 97.202 You must include a ‘Fees and costs summary’ in the body of a shorter PDS for each investment option presented in detail in section 5 of a shorter PDS: see cl 8(1) and (3) of Sch 10E, as modified by [ASIC Corporations \(Disclosure of Fees and Costs\) Instrument 2019/1070](#).
- RG 97.203 The layout of the ‘Fees and costs summary’ is set out in cl 8(3) of Sch 10E, as modified by ASIC Corporations (Disclosure of Fees and Costs) Instrument 2019/1070. You must state that the information in the ‘Fees and costs summary’ can be used to compare costs between different managed investment schemes and state concisely, and in general terms, that fees and costs can be paid directly from the person’s account or deducted from investment returns: see cl 8(6) of Sch 10E, as modified by ASIC Corporations (Disclosure of Fees and Costs) Instrument 2019/1070.
- RG 97.204 We expect you to complete the ‘Fees and costs summary’ in the same way as for a full PDS, as described in RG 97.142–RG 97.164, apart for some minor differences that are detailed in cl 8(3)–(4) of Sch 10E, as modified by ASIC Corporations (Disclosure of Fees and Costs) Instrument 2019/1070.

‘Example of annual fees and costs’

- RG 97.205 You must include an ‘Example of annual fees and costs’ for a balanced investment option in the body of a shorter PDS. If there is no balanced investment option, the ‘Example of annual fees and costs’ must be given for the default investment option. If there is no default option or balanced investment option, the ‘Example of annual fees and costs’ must be for the option under which the simple managed investment scheme has the most funds invested: see cl 8(7) of Sch 10E, as modified by ASIC Corporations (Disclosure of Fees and Costs) Instrument 2019/1070.
- RG 97.206 We expect you to complete the ‘Example of annual fees and costs’ in the same way as the full PDS: see RG 97.166–RG 97.179.

Other fees and costs information

- RG 97.207 You must also provide the fees and costs information for each investment option offered (including for the option profiled in the body of the shorter PDS). This must be provided in accordance with the requirements in Sch 10: see cl 8(10)(a) of Sch 10E. The fees and costs information that should be

provided is the ‘Fees and costs summary’, the ‘Additional explanation of fees and costs’ and the ‘Cost of product information’, but not the ‘Example of annual fees and costs’.

- RG 97.208 You can incorporate this other fees and costs information by reference: see cl 8(10)(a) of Sch 10E. For more information on the Sch 10 requirements for managed investment products and notified foreign passport fund products, see RG 97.140–RG 97.190.
- RG 97.209 You should not include any additional voluntary information in the ‘Fees and costs summary’ or in the ‘Example of annual fees and costs’ of the shorter PDS. Additional voluntary information can, however, be included elsewhere in the ‘Fees and other costs’ section or incorporated by reference. You may provide more detailed information about fees and costs by incorporating it by reference: see cl 8(10)(b) of Sch 10E and reg 7.9.11X. When providing any voluntary information, we encourage you to consider how you can disclose this information in a way that best meets the needs of the types of consumers who invest in your product.

Calculating costs in management fees and costs

- RG 97.210 Costs in management fees and costs for managed investment products and notified foreign passport fund products, including indirect costs, are generally determined based on the costs incurred in the previous financial year. For information on including indirect costs, see RG 97.271–RG 97.282.
- RG 97.211 Exceptions apply if the investment option was not previously offered for a full financial year, or if the investment option was not offered at all during the previous financial year; see Table 5.
- RG 97.212 Fees charged by you to members directly or otherwise to the managed investment scheme that are part of management fees and costs are always disclosed based on what currently applies.
- RG 97.213 We recognise that to calculate costs (under cl 104A(a) and (b) of Sch 10), an estimate may be required if information about costs incurred towards the end of the previous financial year is not available. Clauses 104A(c) and (d) of Sch 10 both require you to make a reasonable estimate of the costs for the current financial year. When you use an estimate, we expect you to specify this in the ‘Additional explanation of fees and costs’. For more information on making reasonable estimates, see RG 97.388–RG 97.397.

Table 5: Calculating costs in management fees and costs

Timing of the offer	What costs must be based on	Reference in Sch 10
The product was offered for the entire previous financial year.	Costs must be based on the costs for that previous financial year.	Clause 104A(a)
The product was offered from at least 11 months before the end of the previous financial year, but for less than a full financial year.	Costs must be based on the costs for that period, adjusted to reflect a 12-month period.	Clause 104A(b)
The product was <i>not</i> offered from at least 11 months before the end of the previous financial year, and was <i>not</i> first offered in the current financial year.	Costs must be based on a reasonable estimate of the costs for the 12-month period derived from costs to date in the current financial year.	Clause 104A(c)
The product was first offered in the current financial year.	Costs must be based on a reasonable estimate of the costs for that part of the current financial year, adjusted to reflect a 12-month period.	Clause 104A(d)

E Managed investment products and notified foreign passport fund products: Periodic statements

Key points

This section explains the fees and costs disclosure requirements for periodic statements for managed investment products or notified foreign passport fund products.

Periodic statements provide each member with information about their account for the relevant reporting period. Periodic statements are generally provided annually and after the member ceases to hold the managed investment product or notified foreign passport fund product.

A periodic statement must contain:

- a 'Transaction list';
- the amount of 'Fees deducted directly from your account' and the approximate amount of 'Fees and costs deducted from your investment';
- the total of all fees and costs disclosed in the periodic statement ('Total fees and costs you paid'); and
- 'Additional explanation of fees and costs'.

Requirement to provide periodic statements

- RG 97.214 You must give members who acquire a managed investment product or notified foreign passport fund product as a retail client a periodic statement for a period of no more than 12 months (reporting period) during which the member holds the product: see s1017D(2). You must give a periodic statement as soon as practicable after the end of the reporting period and, in any event, within six months after the end of the reporting period to which it relates: see s1017D(3).
- RG 97.215 A financial product is provided to a person as a retail client unless s761G(5)–(7) or 761GA provide otherwise: see s761G(1).
- RG 97.216 The fees and costs disclosed in a periodic statement are to be determined over the period to which the periodic statement relates: see cl 104B of Sch 10.

Fees and costs disclosure requirements for periodic statements

- RG 97.217 A periodic statement must give the member the information that you reasonably believe the member needs to understand their investment: see s1017D(4). Detailed content requirements for periodic statements for managed investment products and notified foreign passport fund products are set out in s1017D(5) of the Corporations Act and in Pt 7.9 of the Corporations Regulations, including Subdiv 4C.3 and Divs 5AA and 8.
- RG 97.218 Special content requirements apply for periodic statements for quoted managed investment products or notified foreign passport fund products, including when they form part of a stapled security: see [Class Order \[CO 13/1200\]](#) *Periodic statements relief for AQUA quoted and listed managed investment scheme manager*.
- RG 97.219 Under the fees and costs disclosure requirements, a periodic statement must contain:
- (a) a 'Transaction list';
 - (b) the amount of 'Fees deducted directly from your account' and the approximate amount of 'Fees and costs deducted from your investment';
 - (c) the total of all fees and costs disclosed in the periodic statement ('Total fees and costs you paid'); and
 - (d) 'Additional explanation of fees and costs'.

'Transaction list'

- RG 97.220 Section 1017D(5)(c) requires you to include a list of transactions relating to the managed investment product or notified foreign passport fund product during the reporting period in a periodic statement. The 'Transaction list' must include a brief description of each transaction in relation to the product during the reporting period: see reg 7.9.60B(2).
- RG 97.221 You only need to itemise those fees and costs shown in the 'Fees and costs summary' in the 'Transaction list': see reg 7.9.60B(6). You must describe those fees and costs using the terms used in the 'Fees and costs summary': see reg 7.9.60B(7) and Figure 10. If a fee or cost is not charged, you do not need to include it in the 'Transaction list'.
- RG 97.222 We expect you to only include fees and costs in the 'Transaction list' that are deducted directly from the member's account. The impact of other fees and costs is shown in the 'Fees and costs deducted from your investment': see RG 97.235–RG 97.236.
- RG 97.223 You may describe transactions of the same kind (other than contributions) in a single item in the 'Transaction list' if it is practicable to do so and the items are described together on a consistent basis in the periodic statement:

see reg 7.9.60B(5). You must assess whether a particular grouping of transactions will achieve clear disclosure of the relevant transaction.

- RG 97.224 If you decide to group fees in a single line item, this must not obscure the true frequency or amount of a recurring fee. If relevant, using a subtotal would help meet this objective—for example, ‘a quarterly management fee of \$100 for four quarters (total \$400)’. In some cases, it may not be appropriate to use an annual grouping. If there is a fee increase during the year, this should be set out clearly—for example, ‘a quarterly management fee of 1.1% for two quarters until 31 December 2019 and a quarterly management fee of 1.2% for two quarters until 30 June 2020’.

Note: See s1017D(5A) for amounts that must be stated in dollars.

- RG 97.225 You must also include the amounts the member of the managed investment product or notified foreign passport fund product paid during the period: see reg 7.9.75(1)(a).

Note: Regulation 7.9.75(1)(b) has been omitted by [ASIC Corporations \(Disclosure of Fees and Costs\) Instrument 2019/1070](#).

- RG 97.226 An amount is considered to be paid in respect of a managed investment product or notified foreign passport fund product if:
- (a) the member has paid an amount in respect of the product;
 - (b) an amount has been deducted from a payment made by or to the member;
 - (c) the member has paid an amount, or an amount has been deducted or debited as a fee, expense or charge in relation to the product; or
 - (d) an amount is held on the member’s behalf under the financial product (see reg 7.9.75(2)).

Impact of tax on disclosed transactions

- RG 97.227 You must include, if applicable, GST, stamp duty and income tax (after deductions have been taken into account) in transaction amounts: see reg 7.9.60B(3). We consider that GST should be included less reduced input tax credits.
- RG 97.228 We consider that if GST or stamp duty are not disclosed as part of the transaction amount, they should be reported as separate transactions.
- RG 97.229 If the payment of a fee or cost results in the managed investment product or notified foreign passport fund product becoming entitled to a tax deduction and you pass that tax deduction on to a member, the periodic statement must show two transactions:
- (a) one for the full amount charged; and
 - (b) one for the tax benefit that was passed on to the member (see cl 301(5) of Sch 10).

RG 97.230 When a transaction creates an income tax liability, or a tax deduction is given to the member, we expect you to show this transaction separately and include an explanation of the basis for the transaction and its relationship with other transactions.

‘Fees deducted directly from your account’ and ‘Fees and costs deducted from your investment’

RG 97.231 You must also include the details set out in Pt 3 of Sch 10 in a periodic statement: see regs 7.9.16O and 7.9.75(1)(e). These requirements are set out at RG 97.232–RG 97.239.

RG 97.232 Clause 301(1A) of Sch 10 requires a periodic statement for a managed investment product or notified foreign passport fund product to include certain text (with the appropriate amounts in dollars) after the ‘Transaction list’. Figure 14 shows the text required by cl 301(1A) of Sch 10.

Figure 14: Text required after the ‘Transaction list’

Fees deducted directly from your account

\$[]

This amount has been deducted directly from your account (reflected in the transactions listed on this statement).

Fees and costs deducted from your investment

\$[]

This approximate amount has been deducted from your investment and covers amounts that have reduced the return on your investment and that are not reflected as transactions listed on this statement or in the Additional explanation of fees and costs.

RG 97.233 You must show each of these amounts as a single total amount in dollars: see cl 301(3) of Sch 10.

RG 97.234 The amount to be inserted in the ‘Fees deducted directly from your account’ is the total amount of fees deducted shown on the ‘Transaction list’ in the periodic statement: see cl 301(2)(a) of Sch 10.

RG 97.235 The amount inserted in ‘Fees and costs deducted from your investment’ is an apportioned amount: see cl 301(2)(b) of Sch 10. This is the amount of fees and costs for the product or investment option that are attributed to the particular member, and that are not:

- (a) excluded transactional or operational costs (see RG 97.342–RG 97.346);
- (b) reflected in the ‘Transaction list’ (see RG 97.220–RG 97.230); and
- (c) reflected in the ‘Additional explanation of fees and costs’ in the periodic statement (see RG 97.238–RG 97.239).

- RG 97.236 If the managed investment product or notified foreign passport fund product is subject to tax and a reduced fee or cost is shown in the statement because of the benefit of any income tax deduction, you must include the part of the cost that reduced the disclosed fee or cost in the ‘Fees and costs deducted from your investment’: see cl 301(5) of Sch 10.

‘Total fees and costs you paid’

- RG 97.237 Clause 302(1) of Sch 10 requires a periodic statement to include certain text (with the appropriate amount in dollars), either after ‘Fees and costs deducted from your investment’ or in a summary part of the periodic statement. The amount to be inserted is the total of all fees and costs disclosed in the periodic statement, including any fees detailed in cl 303(2)(a) and (b) of Sch 10: see cl 302(2) of Sch 10. Figure 15 shows the text required in cl 302(1) of Sch 10.

Figure 15: Text required for ‘Total fees and costs you paid’

TOTAL FEES AND COSTS YOU PAID

[\$]

This approximate amount includes all the fees and costs that affected your investment during the period.

‘Additional explanation of fees and costs’

- RG 97.238 Clause 303(2) of Sch 10 requires you to include the following information in a periodic statement for a managed investment product or notified foreign passport fund product, under the heading ‘Additional explanation of fees and costs’, if that information has not been included in another part of the periodic statement:
- (a) details of incidental fees, such as cheque dishonour fees, that were incurred by the member during the period;
 - (b) details of any service fees that may have been incurred by the member; and
 - (c) if the managed investment product or notified foreign passport fund product is subject to tax, whether the benefit of any tax deduction has been passed on to the member in the form of a reduced fee or cost.
- RG 97.239 If details of incidental fees or service fees are shown in the ‘Additional explanation of fees and costs’, these must include the relevant amounts incurred. This ensures that these fees are included in the ‘Total fees and costs you paid’ section, which makes sure that all relevant fees and costs are captured in the periodic statement.

F Platforms: Additional fees and costs disclosure requirements

Key points

This section describes:

- the fees and costs disclosure requirements for PDSs for superannuation platforms and IDPS-like schemes, and IDPS Guides for IDPSs; and
- the fees and costs disclosure requirements for periodic statements for superannuation platforms, IDPS-like schemes and IDPSs.

It also explains how comparisons between products made available through a platform and other products not accessed through a platform must not be misleading.

Disclosure of cost impact for accessible financial products

- RG 97.240 Fees and costs of accessible financial products made available through a platform are not required to be disclosed (in most circumstances) in the PDS (or IDPS Guide) or in the periodic statements of the platform. As the member, rather than the platform operator, chooses to invest in a particular accessible financial product and receives disclosures about that product, the accessible financial product is not considered to be an interposed vehicle for the purposes of fees and costs disclosure: see the platform test described in RG 97.308–RG 97.309.
- RG 97.241 So that members can take into account the cumulative effect of costs at the platform level and in the accessible financial products they select, it is important that members understand that they will incur both:
- (a) fees and costs in relation to the platform; and
 - (b) fees and costs in relation to the relevant accessible financial products.
- RG 97.242 For this reason, and also to ensure that PDSs, IDPS Guides and periodic statements for the platform are not misleading, we expect that you meet the special fees and costs disclosure requirements described at:
- (a) RG 97.244–RG 97.251 for PDSs and IDPS Guides; and
 - (b) RG 97.252–RG 97.258 for periodic statements.

Additional disclosure in platform PDSs and IDPS Guides

- RG 97.243 Platform operators must comply with the PDS requirements for their broad type of product (i.e. superannuation products, managed investment products or notified foreign passport fund products). Therefore, the PDS requirements vary between the different types of platforms. These are:
- (a) *Superannuation platforms*—Superannuation platform operators can prepare either a full PDS or a shorter PDS, depending on the circumstances: see [\[CO 12/749\]](#). For the fees and costs disclosure requirements for a full PDS for a superannuation product, see RG 97.27–RG 97.79. For the fees and costs disclosure requirements for a shorter PDS for a superannuation product, see RG 97.80–RG 97.94.
 - (b) *IDPS-like schemes*—Responsible entities of IDPS-like schemes must prepare a full PDS (not a shorter PDS): see reg 7.9.11S(4), as modified by [Class Order \[CO 13/762\]](#) *Investor directed portfolio services provided through a registered managed investment scheme*. For the fees and costs disclosure requirements for a full PDS for managed investment products or notified foreign passport fund products, see RG 97.138–RG 97.190.
 - (c) *IDPSs*—IDPS operators are exempt from the requirement to prepare a PDS and must instead prepare an IDPS Guide. The guide must provide information about fees and costs in relation to the IDPS that complies with Pt 2 of Sch 10 as if an interest in the IDPS were a managed investment product: see s912AD(5)(e), as notionally inserted by [\[CO 13/763\]](#). These fees and costs disclosure requirements are set out at RG 97.138–RG 97.190.

Special requirements for PDSs and IDPS Guides

- RG 97.244 RG 97.245–RG 97.249 set out our general expectations on platform disclosure. To the extent that you must include specific disclosures as a result of [\[CO 13/762\]](#) or [\[CO 13/763\]](#), we expect you to include those disclosures in addition to the disclosures described in the general guidance at RG 97.245–RG 97.250.
- RG 97.245 To ensure that PDSs (or IDPS Guides) for platforms are not misleading, we expect you to include a prominent statement within either the ‘investment fees and costs’ line item or the ‘management fees and costs’ line item (as applicable) in the ‘Fees and costs summary’ stating that the fees and costs charged by the platform:
- (a) relate only to gaining access to the accessible financial products through the platform; and
 - (b) do not include the fees and costs that relate to investing in accessible financial products.

- RG 97.246 To ensure that consumers are not misled, we expect you to also include prominent statements after the ‘Example of annual fees and costs’ that:
- (a) the fees and costs charged by the platform relate to the platform and access to the accessible financial products only, and do not include the fees and costs that relate to investing in the accessible financial products; and
 - (b) additional fees and costs will be charged by the issuers of the accessible financial products that the investor decides to invest in.
- RG 97.247 You can also help ensure that the PDS (or IDPS Guide) for a platform is not misleading by including an ‘Example of annual fees and costs’ that shows the combined effect of the fees and costs for the platform and the fees and costs for an accessible financial product. This will need to reflect both the fees directly charged by the issuer (e.g. management fees) and the indirect costs to ensure comparability. The accessible financial product used in the example should reflect the typical fees and costs and investment strategy for a major proportion of those products selected by investors in the relevant platform.
- RG 97.248 We also encourage you to provide an example that shows the combined effect of the fees and costs for the platform and for an accessible financial product for each product that can be selected.
- RG 97.249 The examples described in RG 97.247 and RG 97.248 should be prepared in accordance with Div 6 of Pt 2 of Sch 10. In the case of a superannuation platform, the example should take into account the fees and costs for the accessible financial product on the same basis as for a superannuation entity (even if the product is a managed investment scheme).
- RG 97.250 In addition to PDSs (or IDPS Guides), some platform operators provide disclosures—through their platform tools—that allow a consumer to understand the total fees and costs for the platform and the accessible financial products chosen. We support these efforts to increase consumer understanding of fees and costs.
- RG 97.251 In conducting surveillance, we will focus on ensuring that PDS (or IDPS Guide) fees and costs disclosure is not misleading and promotes consumer understanding.

Additional disclosure in platform periodic statements

Special requirements for superannuation platforms and IDPS-like schemes

- RG 97.252 Issuers of superannuation products, managed investment products or notified foreign passport fund products that are platforms must issue periodic

statements to retail clients: see s1017D and Sections C and E of this guide. However, as the member of the superannuation platform or IDPS-like scheme is not the holder of the accessible financial products they select, they will not receive a separate periodic statement for those products.

- RG 97.253 As set out in RG 97.240, the fees and costs of all accessible financial products are not included in the PDS or the periodic statement for the platform, in most circumstances.
- RG 97.254 It is important that members understand that they have incurred fees and costs relating to the accessible financial products they have selected, in addition to the costs charged by the platform that are disclosed in the periodic statement for the superannuation product or IDPS-like scheme.
- RG 97.255 So that the periodic statement gives the member the information you reasonably believe they need to understand their investment (as required by s1017D(4))—and to prevent the periodic statement from being misleading—if it is reasonably practicable to demonstrate the effect of those additional fees and costs, we expect you to include:
- (a) *An additional item for ‘Other fees and costs’ after ‘Total fees and costs you paid’*—we expect you to also include a note saying that this figure is an estimate of all the fees and costs of the accessible financial products based on the actual holdings of the member during the period. The figure must be a reasonable estimate: see RG 97.388–RG 97.397.
 - (b) *An additional item for ‘Total fees and costs you paid—with investment option fees and costs’*—after the new item for ‘Other fees and costs’, and with a note that this figure is the sum of ‘Total fees and costs you paid’ and ‘Other fees and costs’.
- RG 97.256 When it is not reasonably practicable for you to include the items set out at RG 97.255, the periodic statement should include a statement that it does not include the fees and costs for any accessible financial products. We also think it would be appropriate to provide a link to additional information relevant to understanding the costs of accessible financial products, calculated as if they were interposed vehicles, to show the cost of the investment option.
- RG 97.257 We expect you to take reasonable steps to address any limitations in your existing systems to ensure that you will be able to provide information about fees and costs of accessible financial products.

Special requirements for IDPSs

- RG 97.258 IDPS operators are not required to issue periodic statements, but instead they must provide annual investor statements. However, so that members are aware of the fees and costs of the accessible financial products they access through the IDPS, we consider the guidance in RG 97.252–RG 97.257 also applies to IDPS operators when they provide annual investor statements to members.

Other disclosure requirements

- RG 97.259 For superannuation platforms, other requirements may apply if you rely on the relief in [ASIC Corporations \(Superannuation: Investment Strategies\) Instrument 2016/65](#). See also [Regulatory Guide 184](#) *Superannuation: Delivery of product disclosure for investment strategies* (RG 184).
- RG 97.260 For IDPS-like schemes, the requirements in [\[CO 13/762\]](#) will also apply. See also [Regulatory Guide 148](#) *Platforms that are managed investment schemes and nominee and custody services* (RG 148).
- RG 97.261 For IDPSs, the requirements in [\[CO 13/763\]](#) will apply. See also RG 148.

Comparisons must not be misleading

- RG 97.262 In preparing marketing material or financial product advice, we expect you to take care not to make inappropriate or misleading comparisons between platforms and non-platforms. The fees and costs of platforms should not generally be compared with other products in an incomplete manner.
- RG 97.263 For example, it would be misleading to:
- (a) compare the fees and costs for an investment option in a non-platform superannuation entity against the fees and costs for an accessible financial product accessed through a platform, without also including the fees and costs charged by the platform; and
 - (b) compare the fees and costs for a platform against the fees and costs for a non-platform product, without including the fees and costs for the accessible financial products.
- RG 97.264 In relation to personal advice, we expect that a Statement of Advice will cover the fees and costs associated with the platform and how they relate to other fees and costs. This includes the fees and costs of the accessible financial products to be acquired through the platform and those connected with the advice service: see [RG 148](#) at RG 148.189(c).

G Common fees and costs concepts

Key points

This section provides information on fees and costs concepts that are relevant to disclosure for superannuation products, managed investment products, notified foreign passport fund products and platform products, including guidance on:

- the purchase price of an investment (see RG 97.265–RG 97.267);
- fees and costs paid by third parties (see RG 97.268); and
- fees and costs offset by other income (see RG 97.269–RG 97.270).

It also includes guidance on:

- indirect costs (see RG 97.271–RG 97.282);
- the costs associated with derivative financial products (see RG 97.283–RG 97.299);
- how to determine if an underlying entity is an ‘interposed vehicle’ (see RG 97.300–RG 97.330);
- transaction costs, including what is considered an excluded transactional and operational cost (see RG 97.331–RG 97.346); and
- performance fees (see RG 97.347–RG 97.350).

Purchase price of an investment

RG 97.265 The purchase price of an investment or asset is not a fee or cost that must be disclosed under the fees and costs disclosure requirements. The regime aims to capture the fees and costs associated with making investments and deriving returns, not the actual purchase price of an investment or asset.

RG 97.266 The costs associated with making an investment (such as stamp duty for real property or brokerage for shares) are fees and costs that will need to be disclosed: see, for example, indirect costs at RG 97.271–RG 97.282, transaction costs at RG 97.331–RG 97.346, investment fees and costs at RG 97.39–RG 97.42, and management fees and costs at RG 97.150–RG 97.154.

Example

If a superannuation entity or managed investment scheme pays a higher purchase price for an asset because the seller is paying costs the buyer would normally pay (such as stamp duty or land title registration fees on real property), the portion of the higher price that reflects those costs should be disclosed as transaction costs.

RG 97.267 Sometimes, there may be amounts that, for accounting or operational purposes, are capitalised and reflected in the value of the asset that may be

relevant fees and costs. You must ensure that these are included in the fees and costs disclosure in the PDS and/or periodic statements for the product or investment option.

Fees and costs paid by third parties

RG 97.268 Fees and costs include amounts paid by third parties that would have otherwise been charged to, or paid from, the product or investment option. Even if a third party pays a fee or cost, this does not affect its characterisation as a fee or cost for disclosure purposes.

Example

In the previous financial year, a superannuation trustee charged \$1 million as total member fees.

Over that previous financial year, a party related to the superannuation trustee also met some portion of the administration-related costs in relation to the product or investment option by paying \$0.5 million out of their own funds.

Therefore, if these were the only fee and cost amounts relevant to administration, the amount of the costs that were met by third parties that should be included in the administration fees and costs to be shown in the PDS is \$0.5 million, with a total amount of \$1.5 million disclosed as administration fees and costs.

Fees and costs offset by other income

RG 97.269 The fees and costs of a superannuation product, managed investment product or notified foreign passport fund product cannot be reduced or offset by other income. Although an issuer or interposed vehicle may show in its accounts that a fee or cost has been netted off against a particular source of income, this must not be done for fees and costs disclosure purposes. The gross amount of the fee or cost must be disclosed. This is because the regime seeks to disclose costs incurred, regardless of whether these costs generated income.

Income-sharing arrangements

RG 97.270 The fees and costs of a superannuation product, managed investment product or notified foreign passport fund product cannot be reduced or offset through income-sharing arrangements.

Example

A superannuation entity or a managed investment scheme generates income through lending securities, and a custodian keeps a portion of the income as payment for providing the lending service. That portion should

be considered a cost. This cost should be included in ‘investment fees and costs’ (for a superannuation product) or ‘management fees and costs’ (for a managed investment product or notified foreign passport fund product).

Indirect costs

- RG 97.271 Indirect costs seek to capture all relevant costs involved in deriving an investment return for a product or investment option. They are an important part of comprehensive fees and costs disclosure.
- RG 97.272 For superannuation products, indirect costs form part of ‘investment fees and costs’ or ‘administration fees and costs’: see cl 101 of Sch 10. For managed investment products and notified foreign passport fund products, indirect costs form part of ‘management fees and costs’: see cl 102(1)(h) of Sch 10.
- RG 97.273 Indirect costs are defined by cl 101A of Sch 10. The identification of indirect costs commences with a broad assessment of amounts that you know, or reasonably ought to know (or may reasonably estimate), have reduced or will reduce the return on the relevant product or investment option. The reduction can be to the amount or value of the income or property attributable to either:
- (a) the product or option itself; or
 - (b) an interposed vehicle that the product or option is invested in or through.
- RG 97.274 The reduction can occur by deducting costs from the return before receiving it: see cl 101A(1)(a) of Sch 10.
- RG 97.275 However, excluded from indirect costs for superannuation products are amounts of costs that are direct in nature, including:
- (a) an amount that is charged to a member as a fee (see cl 101A(1)(b) of Sch 10);
 - (b) an amount within the meaning of activity fee, advice fee, buy–sell spread, insurance fee or switching fee (see cl 101A(1)(c)(i) of Sch 10); and
 - (c) an amount of administration fees and costs, investment fees and costs, or transaction costs, to the extent it is payable as a cost out of the superannuation entity (see cl 101A(1)(c)(ii) of Sch 10).
- RG 97.276 Indirect costs will then be those amounts that have been paid as a cost out of an interposed vehicle that:
- (a) if they had been paid as a cost out of a superannuation entity, would be certain administration, investment or transaction-related costs (see cl 101A(1)(d)(i)(A)–(C) of Sch 10); or
 - (b) if they had been paid as a cost out of scheme property of a registered scheme or the assets of a notified foreign passport fund, would be certain management-related costs (see cl 101A(1)(d)(ii) of Sch 10).

- RG 97.277 You will normally obtain information about indirect costs from the operators of interposed vehicles that the product or investment option is invested in. As part of due diligence, you may be able to obtain information by requesting it from the operator. You may also be able to obtain information from reporting by the operator or from contracts or other documents. We expect you to hold information about indirect costs paid to related parties. We expect you to also consider any legal obligations you have that may require you to obtain information about indirect costs: see, for example, s52(2)(b) of the SIS Act. For more information on interposed vehicles, see RG 97.300–RG 97.330. For more information on making reasonable estimates, see RG 97.388–RG 97.397.
- RG 97.278 If your investment in an interposed vehicle accounts for only a portion of the total investments in that vehicle, the indirect costs for the product or investment option should only include the portion of the costs attributable to your investment.
- RG 97.279 Indirect costs also include amounts paid by a third party under arrangements where the third party meets the costs of the product or investment option and recoups those costs through paying lower returns to the product or option: see cl 101A(1)(a)(ii) of Sch 10.
- RG 97.280 We expect you to ensure that you apply each element of the tests in cl 101A of Sch 10 when determining if an amount is an indirect cost.
- RG 97.281 For information on calculating indirect costs, see RG 97.100–RG 97.102 (for superannuation products) and RG 97.210–RG 97.213 (for managed investment products and notified foreign passport fund products).
- RG 97.282 Indirect costs also include certain over-the-counter (OTC) derivative costs: see RG 97.283–RG 97.299.

Costs associated with derivative financial products

- RG 97.283 Costs relating to certain kinds of derivative financial products must be included in indirect costs for both superannuation products and managed investment products: see cl 101A(3) of Sch 10.
- RG 97.284 Derivative financial products can be used to gain exposure to other assets in functionally the same way as if the superannuation entity or managed investment scheme had invested in an interposed vehicle. For more information on interposed vehicles, see RG 97.300–RG 97.330.
- RG 97.285 The types of derivative financial products that need to be considered when determining indirect costs are defined in cl 101(3A) of Sch 10. The definition excludes derivatives that are able to be traded on a financial market as the relevant costs must be counted in the same way as other

financial products traded on a financial market. However, it includes securities, collective investment products or other financial products not able to be traded on a financial market that have an embedded derivative (such as a deferred purchase agreement). Provided the derivative financial product meets the definition in cl 101(3A) of Sch 10, it does not matter if it has been specifically manufactured between the counterparties.

- RG 97.286 Holding derivative financial products can incur costs, which may affect the amount you receive or must pay for the product. These costs can affect the underlying return of the superannuation entity or managed investment scheme.
- RG 97.287 These costs may be:
- (a) amounts that you have to pay to the counterparty;
 - (b) reflected in the difference between how much the counterparty pays (or sets off) and the value of the underlying assets or the index of the derivative financial product; and/or
 - (c) charged by the counterparty providing an acquisition price that is higher than the disposal price that would be payable.
- RG 97.288 Indirect costs include amounts relating to derivative financial products when the amount is attributable to:
- (a) the product or investment option (see cl 101A(3)(c) of Sch 10); or
 - (b) an interposed vehicle through which property attributable to the product or investment option is invested (see cl 101A(3)(d) of Sch 10).
- RG 97.289 The costs relating to derivative financial products are generally based on the previous financial year (some exceptions are available when full financial year information is not available): see cls 104 and 104A of Sch 10. Different methods apply for calculations, depending on whether the derivative financial product is an option.

Calculating the costs of derivative financial products

- RG 97.290 When calculating the costs of derivative financial products, you need to determine whether the product is an option. For derivative financial products that are not options, see RG 97.292–RG 97.294. For derivative financial products that are options, see RG 97.295.
- RG 97.291 When the counterparty to a derivative financial product is a related body corporate, we expect that you will know or be able to reasonably estimate the indirect costs of the derivative financial product.

Derivative financial products that are not options

- RG 97.292 For derivative financial products that are not options:
- (a) *If you know or reasonably ought to know (or when this is not the case, may reasonably estimate) the amount*—Include the amount that is the difference between the underlying return and the actual return for the derivative financial product when the actual return on the product or option is less than the underlying return over the relevant financial year: see cl 101A(3)(a)(i) of Sch 10. For more information on making reasonable estimates, see RG 97.388–RG 97.397.
 - (b) *If you do not know, or do not believe you reasonably ought to know, and are not able to reasonably estimate the amount in RG 97.292(a)*—Include the greater of:
 - (i) a default amount calculated using the formula in cl 101A(3)(b)(i)(A) of Sch 10; and
 - (ii) the minimum amount that you believe, or have reasonable grounds to believe, would apply under cl 101A(3)(a)(i) of Sch 10 (see cl 101A(3)(b)(i)(B) of Sch 10).

RG 97.293 The underlying return means the return that has been or would be received, or the loss that would be payable because of the change in value of the ultimate reference assets, taking into account any leverage, offsets or similar adjustments applied to or between the ultimate reference assets under the terms of the relevant derivative financial product over the relevant financial year for which the derivative financial product was held: see cl 101A(3A) of Sch 10.

- RG 97.294 The actual return means the return that has been or would be received, or the loss that would be payable in relation to the derivative financial product over the relevant financial year, if it was:
- (a) acquired at the time it was acquired, or if it was not acquired during the relevant financial year, acquired at the commencement of the relevant financial year for the same price at which it would have been disposed of at the end of the preceding financial year; and
 - (b) disposed of at the time it was disposed of, or if it was not disposed of during the relevant financial year, disposed of at the end of the relevant financial year for the price at which it would have been disposed of at that time (see cl 101A(3A) of Sch 10).

Derivative financial products that are options

- RG 97.295 For derivative financial products that are options:
- (a) *If you know or reasonably ought to know (or when this is not the case, may reasonably estimate) the amount*—Include any amount by which the cost incurred to acquire the derivative financial product exceeds the

amount that would be obtained on its disposal at that time (see cl 101A(3)(a)(ii) of Sch 10). For more information on making reasonable estimates, see RG 97.388–RG 97.397.

- (b) *If you do not know, or do not believe you reasonably ought to know, and are not able to reasonably estimate the amounts in RG 97.292(a)—* Include the lesser of:
- (i) a default amount calculated using the formula in cl 101A(3)(b)(i)(A) of Sch 10 (as if the exclusion of options from that formula did not apply); and
 - (ii) the premium paid by you or the interposed vehicle for the option (see cl 101A(3)(b)(ii)(B) of Sch 10).

Exception for certain derivative financial products used by managed investment schemes

- RG 97.296 As set out at RG 97.283, costs relating to derivative financial products are indirect costs. For managed investment products and notified foreign passport fund products, indirect costs form part of management fees and costs: see cl 102(1)(h) of Sch 10.
- RG 97.297 However, when a managed investment product or notified foreign passport fund product holds a derivative financial product for the primary purpose of avoiding or limiting the financial consequences of fluctuations in, or in the value of, receipts or costs of the managed investment scheme (whether or not the receipts or costs arise in or through an interposed vehicle), the costs of this derivative financial product are not indirect costs: see cl 101A(4)(a) of Sch 10. These costs are therefore not management fees and costs: see cl 102(1)(h) of Sch 10. However, these costs should be disclosed as transaction costs: see cl 103(1)(f) of Sch 10.
- RG 97.298 Examples of the types of derivative financial products that would be excluded as a result of the exception include those used for hedging against changes in interest and exchange rates and negative movements in asset prices. Derivative financial products that are used as a means of achieving the managed investment scheme's investment strategy would not be excluded and so would be counted as indirect costs (and therefore management fees and costs).
- RG 97.299 In addition, when the costs of a derivative financial product held by a managed investment scheme reflect transaction costs (or reflect excluded transactional and operational costs) that would arise if the product held the ultimate reference assets, these costs are also not indirect costs (see cl 101A(4)(b) of Sch 10) and therefore are not management fees and costs: see cl 102(1)(h) of Sch 10. Items within these costs that meet the definition in cl 103(1) of Sch 10 should be disclosed as transaction costs: see cl 103(1)(f) and (h) of Sch 10.

Meaning of ‘interposed vehicle’

- RG 97.300 Superannuation entities, managed investment schemes and notified foreign passport funds often invest in underlying entities (including series or chains of underlying entities) to gain exposure to investments and assets that will produce a return for the product or investment option. These underlying entities can be Australian or foreign and can include a wide variety of structures such as companies, listed and unlisted trusts, and partnerships.
- RG 97.301 Superannuation entities, managed investment schemes and notified foreign passport funds may incur fees and costs relating to each underlying entity they invest in or through (such as management fees or performance fees). These fees and costs, especially when combined over a number of underlying entities, can significantly affect the final return of the product or investment option.
- RG 97.302 Under the fees and costs disclosure requirements, you must disclose the fees and costs of investing in an underlying entity when it is an interposed vehicle. These fees and costs are generally disclosed as indirect costs: see cl 101A(1)(a)(i)(B) of Sch 10.
- RG 97.303 As shown in Figure 16, an interposed vehicle is a ‘body, partnership or trust’ that:
- (a) is not a platform under the ‘platform test’ (see RG 97.308–RG 97.309); and
 - (b) meets either:
 - (i) an ‘assets test’ (see RG 97.311–RG 97.316); *or*
 - (ii) a ‘PDS test’ (see RG 97.317–RG 97.324).
- RG 97.304 The tests in Figure 16 are defined in cl 101B of Sch 10. As shown in Figure 17, a product or investment option will not be invested in or through an interposed vehicle if it is not invested in or through a body, partnership or trust (an entity).
- RG 97.305 We expect you to document and retain records of your decision about whether an entity is an interposed vehicle.
- RG 97.306 We have included examples of entities that would, and entities that would not, be considered interposed vehicles in the appendix to this guide.

Is the entity a platform under the ‘platform test’?

- RG 97.307 If an entity is a ‘platform’, it is not an interposed vehicle. The test for whether an entity is a platform is described in cl 101B(5) of Sch 10. Figure 18 outlines the process for determining whether an entity is excluded from being an interposed vehicle under the platform test.

Figure 16: Definition of an interposed vehicle

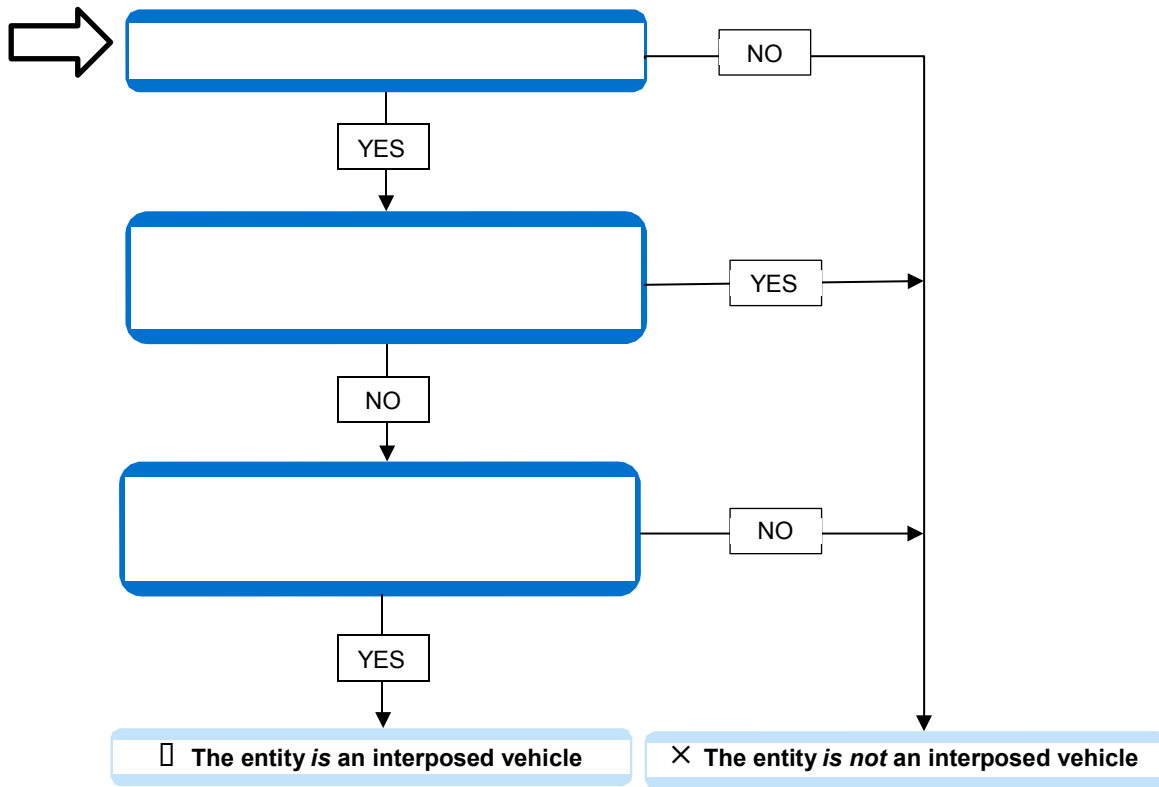

Note: The information in this figure is described in RG 97.303 (accessible version).

Figure 17: Determining whether a product is invested in or through an entity

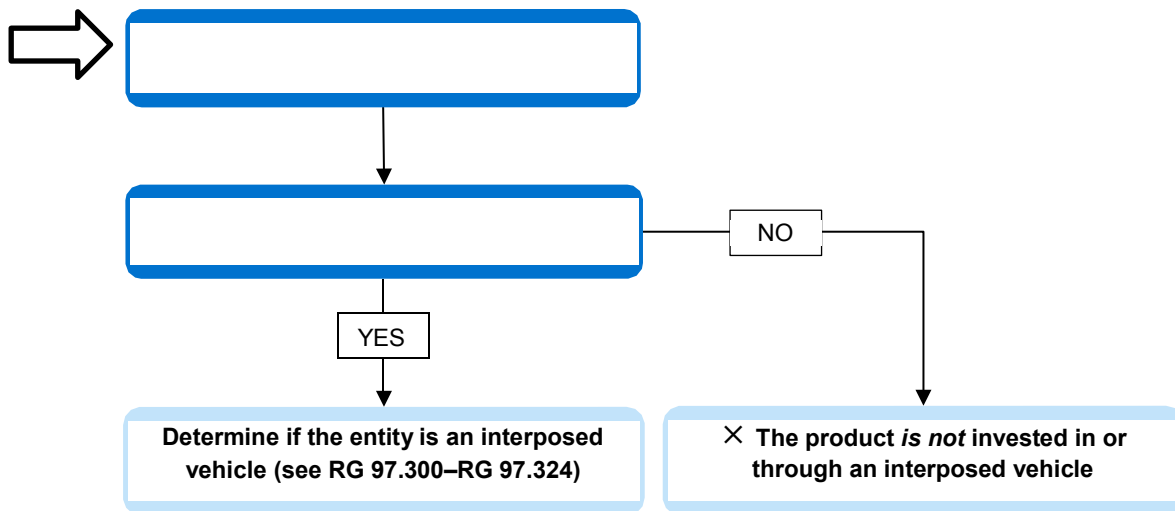

Note: The information in this figure is described in RG 97.304 (accessible version).

RG 97.308 To determine if the entity is a ‘platform’ (for the purposes of being excluded from the definition of an interposed vehicle), you should look at the PDS for the product or investment option, together with its list of accessible investments. An entity will be a platform under the platform test if:

- (a) the PDS states that a holder of the product may give instructions, directions or requests for financial products to be acquired;
- (b) the issuer of the PDS has published a list of financial products the member may choose from and the list includes a security or interest in the entity; and
- (c) the arrangement under which instructions would be acted on is a custodial arrangement (within the meaning of s1012IA(1)).

RG 97.309 If a superannuation entity invests in a managed investment scheme through a platform, the PDS for the superannuation entity would have to provide that members could direct the investments of the superannuation entity. If the PDS does not specify this, the managed investment scheme would be considered to be an interposed vehicle.

Figure 18: Is the entity a ‘platform’ under the ‘platform test’?

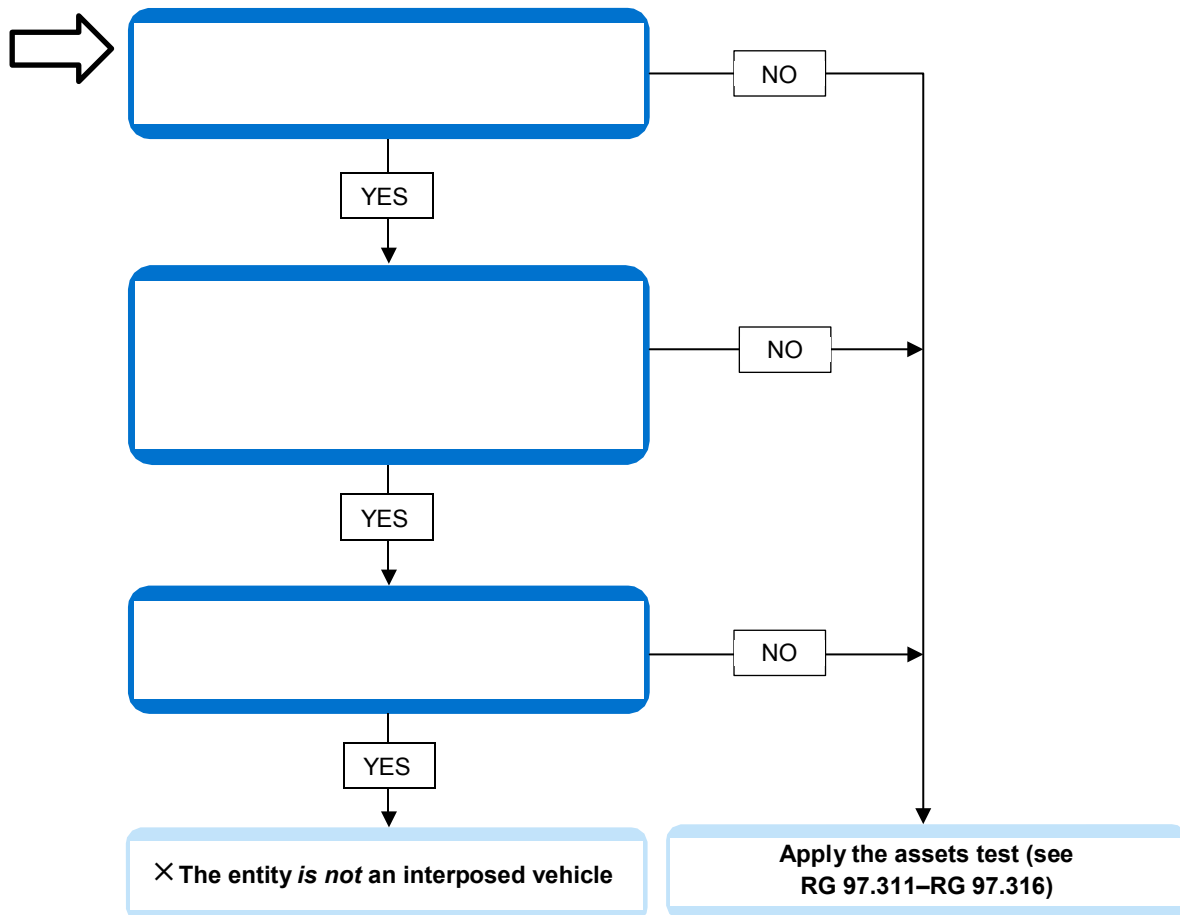

Note: The information in this figure is described in RG 97.308–RG 97.309 (accessible version).

Does the entity meet the ‘assets test’ or ‘PDS test’?

RG 97.310 If the entity is not excluded from the definition of an interposed vehicle under the platform test, it will be an interposed vehicle if it meets:

- (a) the ‘assets test’ (see RG 97.311–RG 97.316); *or*
- (b) the ‘PDS test’ (see RG 97.317–RG 97.324).

The assets test

RG 97.311 The assets test is described in cl 101B(1)–(3) of Sch 10. If an entity meets the assets test, it is an interposed vehicle.

RG 97.312 The assets test is satisfied if you believe, or have reasonable grounds to believe, that the entity has more than 70% of its assets, by value, invested in securities or other financial products (see cl 101B(1)(b) of Sch 10), excluding those securities or financial products in cl 101B(2) of Sch 10: see RG 97.313. We consider that a figure of more than 70% indicates that the entity’s principal business or activity is investing. Figure 19 shows the process for determining whether an entity meets the assets test.

Figure 19: Does the entity meet the ‘assets test’?

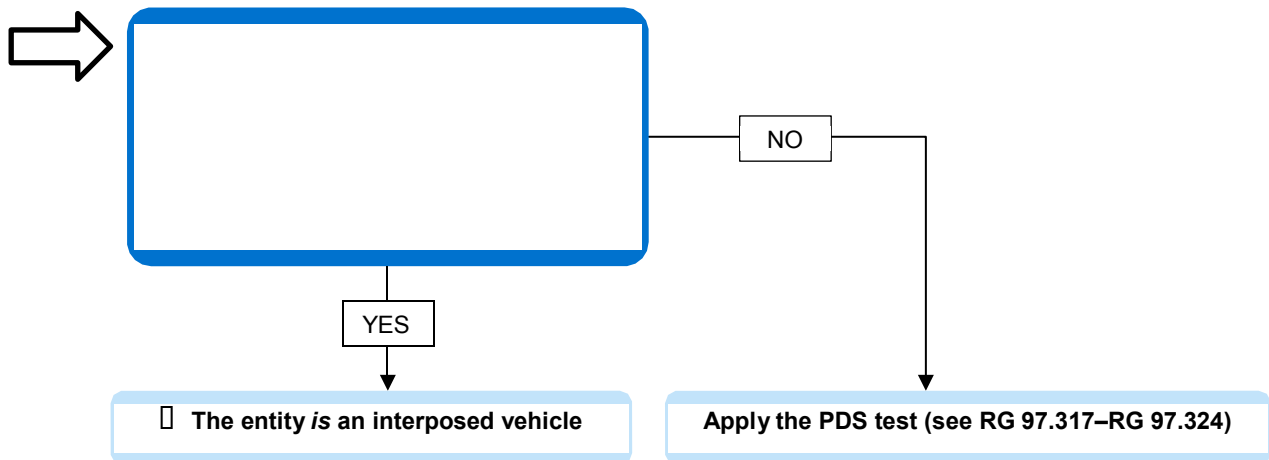

Note: The information in this figure is described in RG 97.311–RG 97.316 (accessible version).

- RG 97.313 When determining the percentage of an entity’s assets, by value, that are invested in securities or other financial products, ignore the following:
- (a) *Controlling interests*: Securities or other financial products that confer control of another entity are excluded, unless you have reasonable grounds to believe the controlled entity has more than 70% of its assets, by value, invested in securities or other financial products: see cl 101B(2)(b) of Sch 10. To determine whether this entity has more than 70% of its assets invested in securities or other financial products, apply the assets test set out in Figure 19: see cl 101B(3) of Sch 10. This exclusion ensures that entities holding securities or financial products in other entities for

operational reasons (such as being in a corporate group structure), rather than because they are an investment business, are not inadvertently captured by the assets test.

- (b) *Investments in real property or infrastructure*: Financial products that are reasonably regarded as a means by which the entity invests in real property or an infrastructure entity, as defined in cl 101B(6) of Sch 10, are excluded: see cl 101B(2)(a) of Sch 10. In formulating the assets test, we identified that certain real property and infrastructure investments would satisfy the assets test due to the way these types of investments are normally structured (e.g. when a managed investment scheme invests in shares in an entity or series of entities that hold land or infrastructure). We determined that the PDS test (see RG 97.317–RG 97.324) would be more appropriate for establishing whether the entity was the *end investment* or the *means* by which the managed investment scheme gained exposure to the end investment (i.e. the real property or infrastructure asset).

RG 97.314 Identifying whether an entity is an interposed vehicle under the assets test is based on what you believe, or have reasonable grounds to believe. ‘Having reasonable grounds to believe’ is more than a mere reason to suspect. In *George v Rockett* (1990) 170 CLR 104, the High Court held at 112 that:

When a statute prescribes that there must be ‘reasonable grounds’ for a state of mind—including suspicion and belief—it requires the existence of facts which are sufficient to induce that state of mind in a reasonable person.

RG 97.315 As part of properly performing your duties as a superannuation trustee, responsible entity or operator, you may have information that may give you reasonable grounds to believe that an entity meets the assets test. This information might be information about the entity or about its investment strategy.

RG 97.316 You are not explicitly required to make outside inquiries when applying the assets test. However, if you are uncertain about whether an entity is an interposed vehicle and this would have a material effect on the amount of fees and costs you disclose, we expect you to make further reasonable inquiries to determine whether it is.

The PDS test

RG 97.317 If an entity is not a platform under the platform test, and does not meet the assets test, it may be an interposed vehicle under the PDS test. If an entity meets the PDS test, it is an interposed vehicle. The PDS test is described in cl 101B(4)–(4D) of Sch 10.

RG 97.318 The PDS test should be applied by looking at the disclosures in the PDS of the product or investment option and other information you have prepared (such as promotional material). The structure of an investment does not affect the outcome of the PDS test.

RG 97.319 The PDS test has three limbs: see RG 97.320–RG 97.324. If any one of these limbs is satisfied, the entity is an interposed vehicle.

First limb of the PDS test: see cl 101B(4) of Sch 10

RG 97.320 An entity will be an interposed vehicle for a product or investment option if, based on the PDS for the product or option and any other information issued by you, a security or interest in the entity could reasonably be regarded (by retail clients who may be expected to be given the PDS or other information) as the *means* by which the benefit of the investment is obtained, rather than the *end investment*: see Figure 20.

Note: Often, a listed entity will not be an interposed vehicle. Generally, a listed entity is part of an equities portfolio, which seeks returns from increases in the entity's market price and from income paid to members, rather than through increases in the value of the assets of the entity.

Figure 20: Does the entity meet the first limb of the PDS test?

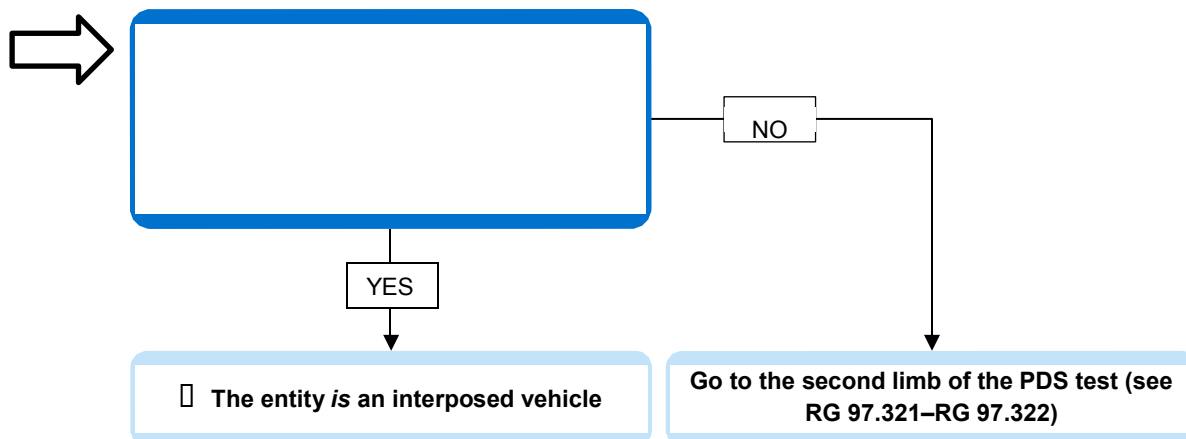

Note: The information in this figure is described in RG 97.320 (accessible version).

Second limb of the PDS test: see cl 101B(4A) and (4B) of Sch 10

- RG 97.321 If the first limb of the PDS test is not satisfied, an entity is an interposed vehicle under the second limb if:
- (a) the PDS and any other information you issued (that has been given to retail clients, or may reasonably be expected to be given to them) refers to ‘property’, ‘real estate’ or ‘land’ (or similar terms):
 - (i) in the description of the product or investment option; or
 - (ii) as one of the assets of the product or investment option; and
 - (b) real property or an interest in land is held by or through the entity (directly or indirectly) (see Figure 21).
- RG 97.322 However, under the second limb, an entity is not an interposed vehicle (but may be under the first or third limb) if:

- (a) the reference in the PDS or other information is merely part of a reference to an entity (whether specified or not) that invests (directly or indirectly) in real property, interests in land or certain types of physical infrastructure (see cl 101B(6)(a)–(k) of Sch 10); and
- (b) a retail client who has read the PDS or other information could not reasonably believe that the product, investment option or asset may be intended for people predominantly intending to benefit from increases in the value of, or returns from, real property or an interest in land (other than certain types of physical infrastructure).

Figure 21: Does the entity meet the second limb of the PDS test?

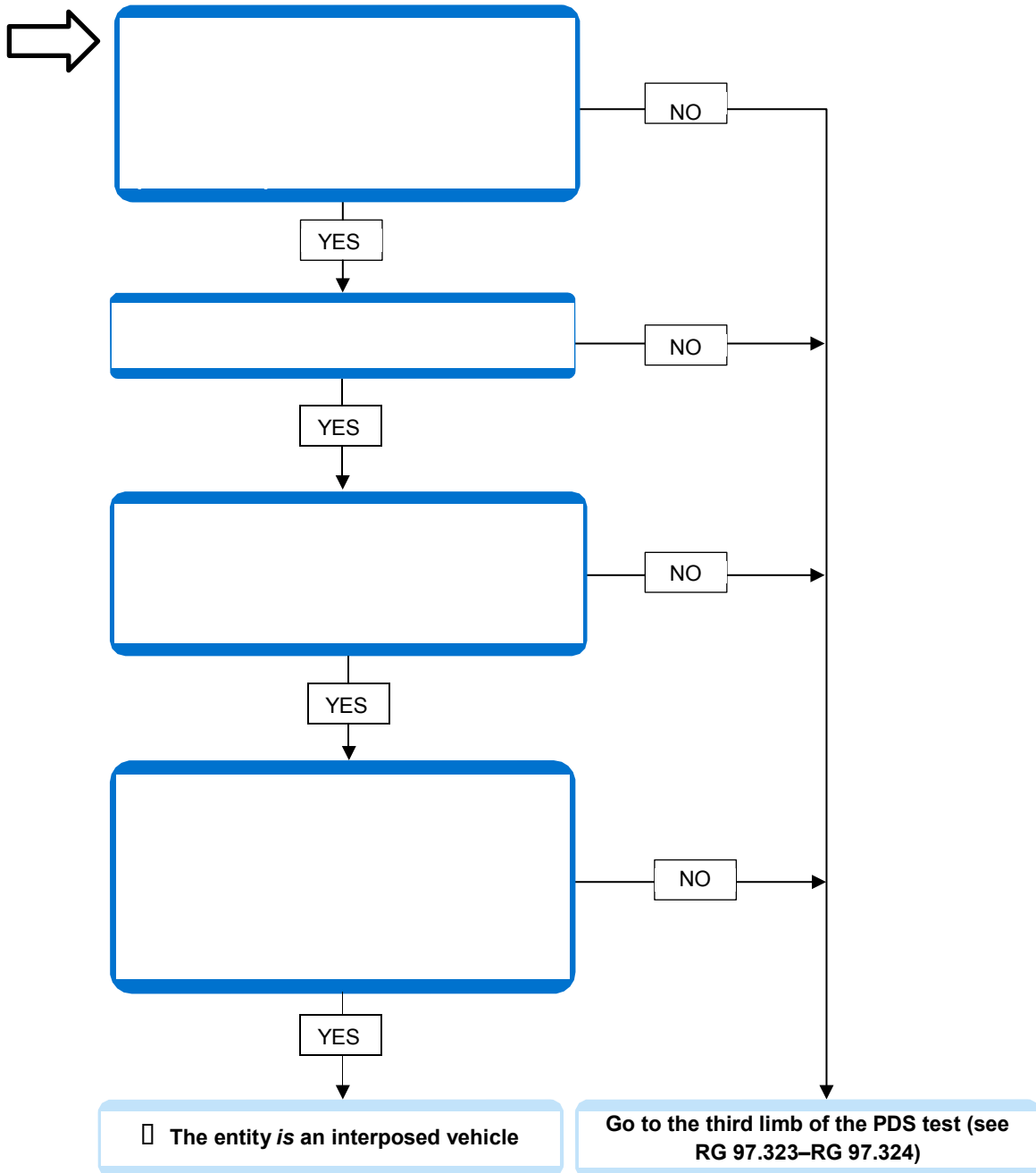

Note: The information in this figure is described in RG 97.321–RG 97.322 (accessible version).

Third limb of the PDS test: see cl 101B(4C) and (4D) of Sch 10

RG 97.323 If the first or second limbs of the PDS test are not satisfied, an entity is an interposed vehicle under the third limb if the PDS for the relevant product or investment option (and any other information you issued) refers to the product or option as being directly or indirectly invested in, or through, the entity (whether specified or not) and the reference relates to the entity.

RG 97.324 However, under the third limb and as shown in see Figure 22, an entity will not be an interposed vehicle (but may be under the first or second limb) if:

- (a) you believe the entity invests the majority of its assets in certain types of physical infrastructure (see cl 101B(6)(a)–(k) of Sch 10); or
- (b) all of the following are satisfied:
 - (i) the entity is listed or will be listed;
 - (ii) the securities or financial products of the entity are held under an investment strategy that relates to, or is publicly measured by, a widely used index of listed assets;

Figure 22: Does the entity meet the third limb of the PDS test?

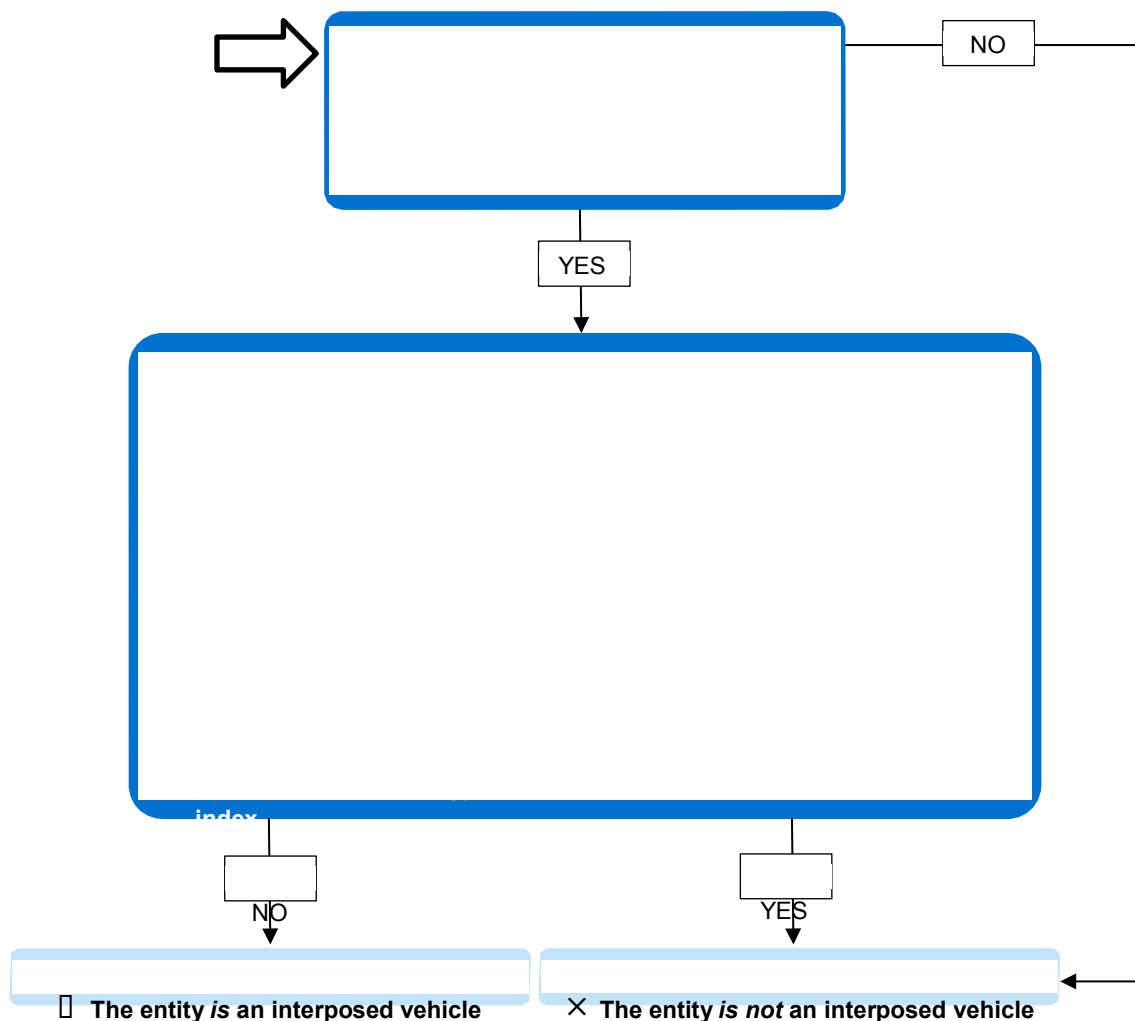

Note: The information in this figure is described in RG 97.323–RG 97.324 (accessible version).

- (i) the investment strategy is to invest in listed assets;
- (ii) the listed assets represent at least 80%, by value, of the net assets attributable to the investment strategy; and
- (iii) the value of all the securities or financial products of the entity that are in the same class as the securities or financial products held under the investment strategy does not exceed 30% of the value of the index.

Marketing material and comparisons must not be misleading

- RG 97.325 If you have determined that an entity is the *end investment* and not an interposed vehicle under the PDS test, your marketing material and any comparisons you make will need to be consistent with that view. Otherwise, your marketing material and any comparisons made will be misleading.
- RG 97.326 For example, a product holding securities in a listed Australian real estate investment trust (AREIT) under an option that is described as an equities portfolio should not be included in a comparison of an option that holds direct commercial property.

Determining whether other entities in the investment chain are interposed vehicles

- RG 97.327 If you have determined that an entity is an interposed vehicle, you must then establish whether it forms part of a chain of entities. If it is part of a chain, you must apply the interposed vehicle tests set out at RG 97.307–RG 97.324 to the next downstream entity in the chain.
- RG 97.328 If the next downstream entity is an interposed vehicle, then the costs of that entity must be included when calculating indirect costs: see cl 101A(2) of Sch 10. You must then apply the interposed vehicle test to the next downstream entity in the chain.
- RG 97.329 If the downstream entity is not an interposed vehicle, then its costs are not included when calculating indirect costs.
- RG 97.330 If you have determined that a downstream entity is not an interposed vehicle, further downstream entities in the chain are also not considered to be interposed vehicles.

Transaction costs

- RG 97.331 Transaction costs are costs incurred when assets are bought or sold. The type of transaction costs will depend on the type of assets. For example, buying or selling real property would normally incur stamp duty. Buying or selling listed securities may incur brokerage.

- RG 97.332 Transaction costs are defined in cl 103(1) of Sch 10 to include:
- (a) brokerage;
 - (b) buy–sell spread (see RG 97.340–RG 97.341);
 - (c) settlement costs (including custody costs);
 - (d) clearing costs; and
 - (e) stamp duty.
- RG 97.333 Examples of the types of things that may also be included in transaction costs are:
- (a) due diligence costs;
 - (b) sales commission on property transactions;
 - (c) legal, advisory and other professional costs; and
 - (d) any failed deal costs.
- RG 97.334 For managed investment products and notified foreign passport fund products, transaction costs also include costs relating to derivative financial products that are used for certain specified purposes: see cls 101A(4) and 103(1)(f) of Sch 10 and RG 97.283–RG 97.299.
- RG 97.335 Transaction costs also include costs incurred by an interposed vehicle that would be transaction costs if they had been incurred by the superannuation entity, managed investment scheme or notified foreign passport fund: see cl 103(1)(g) of Sch 10.
- RG 97.336 For superannuation products, transaction costs include costs that are debited from reserves that, in a period, exceed amounts credited to reserves in that period that are also transaction costs: see cl 103(1)(ga) of Sch 10 and RG 97.95–RG 97.99.
- RG 97.337 Transaction costs do not include:
- (a) excluded transactional and operational costs (see cl 103(1)(h) of Sch 10 and RG 97.342–RG 97.346); or
 - (b) costs that are charged as other types of fees and costs (see cl 103(1)(i) of Sch 10).
- RG 97.338 For information on how to calculate transaction costs, see RG 97.367–RG 97.369.
- RG 97.339 We expect the industry to adopt best execution strategies that will be formal obligations in some markets. ASIC intends to keep these best execution concerns in mind as part of our surveillance activities. We may act if we see a trend emerging where investment pathways are shifted in an attempt to make the fees and costs disclosed appear lower than they actually are.

Buy–sell spread

- RG 97.340 Buy–sell spread is specifically included as a transaction cost: see cl 103(1)(b) of Sch 10.
- RG 97.341 The buy–sell spread that forms part of the transaction costs is the buy–sell spread you incur in respect of the underlying investments of a superannuation product, managed investment product or notified foreign passport fund product: see paragraph (c) of the definition of buy–sell spread in cl 101 of Sch 10.

Example

The responsible entity of a managed investment scheme charges a superannuation trustee a buy–sell spread if the superannuation entity invests in, or exits, the managed investment scheme.

This is different from the buy–sell spread that is charged to members on entry and exit from a superannuation product or investment option or managed investment product or option, which appears in the 'Fees and costs summary': see paragraphs (a) and (b) of the definition of buy–sell spread in cl 101 of Sch 10.

Excluded transactional and operational costs

- RG 97.342 Some types of costs (called excluded transactional and operational costs) are not included in the disclosure of fees and costs in PDSs and periodic statements.
- RG 97.343 These costs are defined in cl 103(2) of Sch 10 and comprise:
- (a) borrowing costs;
 - (b) property operating costs; and
 - (c) implicit transaction costs or market impact costs.
- RG 97.344 Some examples of implicit transaction costs or market impact costs are:
- (a) when an asset is acquired other than through a financial market, any part of the acquisition price of the asset that exceeds the price at which the asset could have been disposed of; and
 - (b) when an asset is acquired through a financial market, any part of the acquisition price of the asset that exceeds the bid price in the financial market that would apply without the acquisition having occurred, either immediately following the acquisition or if the acquisition was a part of multiple acquisitions reflecting a single and non-recurring instruction to acquire, after the last acquisition made in accordance with the instruction.
- RG 97.345 Although excluded transactional and operational costs are not disclosed in PDSs and periodic statements, this does not mean these types of costs are not important. We expect you to monitor these costs to ensure that members are receiving the best value for money. See also s52(2)(c) of the SIS Act and

s601FC(1)(c) of the Corporations Act, which require superannuation trustees and responsible entities to act in the best interests of members.

RG 97.346 We expect that you take care to ensure that you properly categorise transaction costs. If you incorrectly characterise a transaction cost as an excluded transactional and operational cost and therefore do not disclose it as part of the fees and costs, your PDS or periodic statement will not comply with the fees and costs disclosure requirements and may be misleading. We will observe market practices and developments and review whether the exclusion is operating as intended.

Performance fees

RG 97.347 A performance fee is an amount paid or payable that is calculated by reference to the performance of:

- (a) a managed investment product or notified foreign passport fund product;
- (b) a superannuation product;
- (c) a MySuper product;
- (d) an investment option;
- (e) an interposed vehicle; or
- (f) part of a product, investment option or interposed vehicle (see cl 101C(1) of Sch 10).

RG 97.348 'Performance' includes:

- (a) income in relation to the assets of, or attributed to, the product, investment option or interposed vehicle, or part; and
- (b) capital appreciation (realised or unrealised) to the value of the product, investment option or interposed vehicle, or part (see cl 101C(2) of Sch 10).

RG 97.349 For superannuation products, performance fees form part of investment fees and costs: see paragraph (a) of the definition of investment fees and costs in cl 101 of Sch 10. 'Investment fees and costs' is a line item in the 'Fees and costs summary': see cl 201 of Sch 10.

RG 97.350 For managed investment products and notified foreign passport fund products, performance fees are included as a line item in the 'Fees and costs summary': see cls 202–202A of Sch 10. For information on how to calculate and disclose performance fees, see RG 97.374–RG 97.387.

H Calculating and presenting fees and costs

Key points

This section provides guidance on how to calculate and present fees and costs information for superannuation products, managed investment products and notified foreign passport fund products, including guidance on:

- collecting and compiling data for fees and costs disclosures (see RG 97.351);
- filling in the 'Fees and costs summary' (see RG 97.352–RG 97.361);
- disclosing fees and costs for multiple investment options (see RG 97.365–RG 97.366);
- calculating and disclosing transaction costs (see RG 97.367–RG 97.373);
- calculating and disclosing performance fees (see RG 97.374–RG 97.387);
- making reasonable estimates (see RG 97.388–RG 97.397); and
- the impact of tax on fees and costs disclosures in PDSs (see RG 97.398–RG 97.400).

Collecting and compiling data for fees and costs disclosures

- RG 97.351 To produce accurate outcomes for consumers in fees and costs disclosure, you need to take steps to institute appropriate governance arrangements for collecting and compiling fees and costs information. Compliance with fees and costs obligations will be promoted if you:
- (a) document calculation methodologies and due diligence processes; and
 - (b) consider in your arrangements with service providers, people offering investment opportunities and interposed vehicles (see RG 97.300–RG 97.330) how the data that is necessary for fees and costs disclosure for your products will be provided to you.

Filling in the 'Fees and costs summary'

The preamble

- RG 97.352 We expect that you only include material in the preamble to the 'Fees and costs summary' that is relevant to the product: see cl 203 of Sch 10.

The 'Amount' column

- RG 97.353 If it is not possible to determine a single amount or percentage of a fee or cost, you can include a range: see cl 204(3) of Sch 10. For example, if a fee

or cost can apply at varying rates over a particular time, we expect you to show a range.

- RG 97.354 When a fee or cost will vary so that a certain maximum applies for a particular period and then another maximum applies, we expect you to disclose these amounts as two separate entries in the 'Fees and costs summary'. If a fee or cost may vary between members, we expect you to include the maximum amount expected to apply to any member.
- RG 97.355 If you do not know the exact amount of fees or costs, you must show a reasonable estimate of the amount attributable to the retail client and clearly identify it as an estimate: see cl 204(4)–(5) of Sch 10. For more information on making reasonable estimates, see RG 97.388–RG 97.397.
- RG 97.356 If an amount or cost has several components, you must list the amount of each component separately: see cl 204(6) of Sch 10. We consider 'components' to refer to the structure of the fees and costs charging arrangements adopted by you (such as dollar and percentage amounts). For example, management fees and costs could be disclosed as '1.8% of the member's balance, plus \$70 per year'. We do not consider 'components' to refer to the different items that can make up the fees and costs as defined in Sch 10, and which must be disclosed in the 'Fees and costs summary' or in the 'Example of annual fees and costs' (such as indirect costs that form part of investment fees and costs for superannuation products).
- RG 97.357 In considering the fees and costs structures for your products, we expect you to also take into account how easily the components of the structure can be described in the line items in the 'Fees and costs summary', and whether consumers will understand this. For example, if an amount or cost has a number of components with complex interactions, it may be difficult to describe them in a way that is readily understood by consumers and is not misleading. This may also make it difficult for consumers and others to compare fees and costs between products.
- RG 97.358 You must include GST (less any reduced input tax credits) and stamp duty (where applicable): see cl 204(7)(a) of Sch 10.
- RG 97.359 If a particular fee or cost is not charged, you must write 'nil', 'zero', '0' or 'not applicable' in the 'Amount' column (if it would not be misleading): see cl 204(2) of Sch 10. If a fee or cost is only payable on a contingency, you must still disclose the relevant amount.

Note: If a performance fee is negative, for a managed investment product or notified foreign passport fund product, it must not be disclosed in the 'Fees and costs summary'. Instead, in the 'Amount' column, insert the text 'See Additional explanation of fees and costs.' See cl 204B of Sch 10.

The ‘How and when paid’ column

- RG 97.360 In the ‘How and when paid’ column of the ‘Fees and costs summary’, you must set out:
- (a) how the amount is or will be recovered (e.g. deducted from the member’s investment balance or from the superannuation entity’s or managed investment scheme’s assets, contributions or withdrawals);
 - (b) the frequency of recovery; and
 - (c) the timing of recovery (see cl 207(a)–(c) of Sch 10).
- RG 97.361 If a superannuation entity has more than one option for paying fees, or if a managed investment product or notified foreign passport fund product has more than two options, you must set out the number of options in the preamble and include details in the ‘Fees and costs summary’: see cl 206 of Sch 10.

Negotiable fees

- RG 97.362 You must clearly indicate in the ‘Fees and costs summary’ which fees and costs are negotiable: see cl 208(1) of Sch 10. You must also include a cross-reference to the ‘Additional explanation of fees and costs’: see cl 208(2) of Sch 10.
- RG 97.363 In addition, you must include in the ‘Additional explanation of fees and costs’ the contact details of the person or body with whom the fee or cost can be negotiated and the manner of negotiation: see cl 209(g) of Sch 10.
- RG 97.364 For more information on the ‘Additional explanation of fees and costs’, see RG 97.71–RG 97.79 (for superannuation products) and RG 97.185–RG 97.190 (for managed investment products and notified foreign passport fund products).

Disclosing fees and costs for multiple investment options

- RG 97.365 When the same fees and costs apply to multiple investment options, you may state in the PDS that the ‘Fees and costs summary’, the ‘Example of annual fees and costs’, the ‘Cost of product information’ and the ‘Additional explanation of fees and costs’ relate to all relevant options.
- RG 97.366 You do not have to repeat the same information multiple times. This would be relevant, for example, for ‘Cost of product information’ if the only fees and costs that would be included for an option would be those of the superannuation entity, managed investment scheme or notified foreign passport fund itself and not of any interposed vehicles, due to the operation of the platform test: see RG 97.308–RG 97.309.

Calculating and disclosing transaction costs

RG 97.367 Transaction costs disclosed in a PDS are generally determined based on the transaction costs incurred in the previous financial year. There are exceptions, however, if the product or investment option was:

- (a) offered for only some of the previous financial year; or
- (b) was not offered at all during the previous financial year.

Table 6: How to calculate transaction costs for products and investment options

Timing of offer	What costs must be based on	Reference in Sch 10
The product or option was offered for the entire previous financial year.	Costs must be based on the costs for that previous financial year.	See cl 103A(a)
The product or option was offered from at least 11 months before the end of the previous financial year, but for less than a full financial year.	Costs must be based on the costs for that period, adjusted to reflect a 12-month period.	See cl 103A(b)
The product or option was <i>not</i> offered from at least 11 months before the end of the previous financial year, and <i>not</i> first offered in the current financial year.	Costs must be based on a reasonable estimate of the transaction costs for the 12-month period of the current financial year at the time the PDS is prepared.	See cl 103A(c)
The product or option was first offered in the current financial year.	Costs must be based on a reasonable estimate of the transaction costs for that part of the current financial year at the time the PDS is prepared, adjusted to reflect a 12-month period.	See cl 103A(d)

RG 97.368 We recognise that to calculate costs (under cl 103A(a) and (b) of Sch 10), an estimate may be required if information about costs incurred towards the end of the previous financial year is not available.

RG 97.369 Clauses 103A(c) and (d) of Sch 10 both require you to make a reasonable estimate of the transaction costs for the current financial year. When you use an estimate, we expect you to specify this in the ‘Additional explanation of fees and costs’. For more information on making reasonable estimates, see RG 97.388–RG 97.397.

Disclosing transaction costs in the ‘Additional explanation of fees and costs’

RG 97.370 Under cl 209(j) of Sch 10, certain information about transaction costs must be included in the ‘Additional explanation of fees and costs’ for superannuation products, managed investment products and notified foreign passport fund products, to the extent that the information is relevant to the particular product.

- RG 97.371 Importantly, this includes the amount of total gross transaction costs, or an estimate if the amount is not known: see cl 209(j)(i) of Sch 10. This amount must show the gross amount of transaction costs that are attributable to a retail client.
- RG 97.372 Doing so enables a comparison between this amount and the amount of transaction costs in the ‘Fees and costs summary’: see cl 204A of Sch 10. The latter amount shows the amount of transaction costs net of any amount recovered through the buy–sell spread charged by the superannuation trustee, responsible entity or operator that is attributable to a retail client: see RG 97.43–RG 97.44 (for superannuation products) and RG 97.159–RG 97.160 (for managed investment products and notified foreign passport fund products).
- RG 97.373 You must include the following information about transaction costs in the ‘Additional explanation of fees and costs’:
- (a) a statement that the transaction costs shown in the ‘Fees and costs summary’ are shown net of any amount recovered by the buy–sell spread that is charged by the superannuation trustee, responsible entity or operator (see cl 209(j)(ii) of Sch 10);
 - (b) a description of each cost (see cl 209(j)(iii) of Sch 10);
 - (c) how and when the costs are recovered (see cl 209(j)(iv) of Sch 10); and
 - (d) a statement that the cost is an additional cost to the member when it has not already been recovered by the buy–sell spread charged by the superannuation trustee, responsible entity or operator of a notified foreign passport fund (see cl 209(j)(v) of Sch 10).

Calculating and disclosing performance fees

- RG 97.374 Performance fees in a PDS are calculated based on an average of the previous five financial years. In broad terms:
- (a) each performance fee relevant to a product or investment option is averaged;
 - (b) the resulting averages are totalled to give the performance fees for the entire product or investment option; and
 - (c) the total is then added to investment fees and costs (for superannuation products) or performance fees (for managed investment products and notified foreign passport fund products).
- RG 97.375 To calculate the total performance fees for a PDS, you must include the performance fees that accrued in relation to:
- (a) the product or investment option, or part of the product or option, averaged over the previous five financial years; and

- (b) any interposed vehicle referable to that product, investment option, or part of the product or option, averaged over the previous five financial years (see cl 101C(3) of Sch 10).

- RG 97.376 When a product, investment option or interposed vehicle or part was not operating for the previous five financial years, calculate the average by reference to the number of financial years in which it operated: see cl 101C(3)(b) of Sch 10. When the product, option or interposed vehicle or part did not have a performance-fee-charging mechanism in place in each of the previous five financial years, calculate the average by reference to the number of financial years in which it had a performance-fee-charging mechanism in place: see cl 101C(3)(c) of Sch 10.
- RG 97.377 When a product, investment option or interposed vehicle or part was first offered in the current financial year, calculate the average by referring to your reasonable estimate of the performance fee for the current financial year, adjusted to reflect a 12-month period: see cl 101C(3)(d) of Sch 10. For more information on making reasonable estimates, see RG 97.388–RG 97.397.
- RG 97.378 In calculating the total performance fees, you may factor in any clawback (a refund or reduction of a performance fee due to poor performance) for individual years.
- RG 97.379 This total figure for performance fees must then be applied for the purposes of calculating and disclosing ‘investment fees and costs’ for superannuation products (see RG 97.39–RG 97.42) and ‘performance fees’ for managed investment products and notified foreign passport fund products (see RG 97.150–RG 97.154).
- RG 97.380 When calculating performance fees for a periodic statement, include the performance fees for the reporting period to which the statement relates: see cl 101C(4) of Sch 10.

Disclosing performance fees in the ‘Fees and costs summary’

- RG 97.381 You must insert a footnote in the ‘Fees and costs summary’ for superannuation products (see cl 201 of Sch 10) when performance fees are included in investment fees. You must insert a percentage for performance fees and include a cross-reference to the ‘Additional explanation of fees and costs’ where a statement about how performance fees affect administration fees and costs and investment fees and costs is set out: see cl 209(b)(i) of Sch 10 and RG 97.384.
- RG 97.382 You must disclose performance fees in the ‘Fees and costs summary’ for managed investment products and notified foreign passport fund products: see cls 202 and 202A of Sch 10. When the performance fee is negative, you

must insert in the ‘Amount’ column the text ‘See Additional explanation of fees and costs’, which will point the member to more information: see cl 204B of Sch 10.

Disclosing performance fees in the ‘Additional explanation of fees and costs’

- RG 97.383 Clause 209(b) of Sch 10 requires you to include certain information about performance fees in the ‘Additional explanation of fees and costs’ for superannuation products, managed investment products and notified foreign passport fund products, to the extent the information is relevant to the particular product.
- RG 97.384 The information required is:
- (a) for superannuation products—a statement about how performance fees affect administration fees and costs and investment fees and costs (see cl 209(b)(i) of Sch 10);
 - (b) for a managed investment product or notified foreign passport fund product—details, including the amount, for performance fees chargeable by the responsible entity or operator (see cl 209(b)(ii) of Sch 10);
 - (c) the method for calculating the total performance fees included in the ‘Fees and costs summary’ (see cl 209(b)(iii) of Sch 10)—this is the method for calculating the total performance fees to be included in investment fees and costs or performance fees, not the calculation method used for each individual performance fee;
 - (d) if applicable, the details of negative performance fees and their effect on fees and costs (see cl 209(b)(iv) of Sch 10); and
 - (e) the calculated average performance fees for each product or investment option or interposed vehicle or part under cl 101C(3)(a) of Sch 10 (see cl 209(b)(v) of Sch 10).
- RG 97.385 You may provide a further explanation in the ‘Additional explanation of fees and costs’ if you believe the average figure based on the previous five financial years is not representative for the coming period. However, you must still use the average figure based on the previous five financial years in your disclosure.
- RG 97.386 You may also include other performance-related information in the ‘Additional explanation of fees and costs’.
- RG 97.387 We expect you to consider whether it is appropriate to include information about performance fees under other PDS content requirements.

Making reasonable estimates

- RG 97.388 In some circumstances, the fees and costs disclosure requirements specify that you must make a reasonable estimate of a fee or cost if you cannot determine the exact number. We have also set out in this guide other circumstances when we recognise that a reasonable estimate may be required: see, for example, RG 97.255.
- RG 97.389 You can use reasonable estimates, if you cannot determine the exact number, for:
- (a) an amount of indirect costs (see cl 101A(1) of Sch 10);
 - (b) the indirect costs for a derivative financial product (see cl 101A(3)(a) of Sch 10);
 - (c) the amount attributable to a retail client that you will show in the ‘Fees and costs summary’ (see cl 204(4) of Sch 10);
 - (d) performance fees that you will show in the ‘Fees and costs summary’ (see cl 204(4) of Sch 10); and
 - (e) the total gross transaction costs you will show in the ‘Additional explanation of fees and costs’ (see cl 209(j)(i) of Sch 10).
- RG 97.390 If you have not previously offered a product or investment option for a full financial year, or if the product or option was first offered in the current financial year, you can use reasonable estimates of:
- (a) the costs in administration fees and costs and investment fees and costs for a superannuation product, including indirect costs (see cl 104(1)(c)–(d) of Sch 10);
 - (b) the costs in management fees and costs for a managed investment product or notified foreign passport fund product, including indirect costs (see cl 104A(c)–(d) of Sch 10);
 - (c) the performance fees for a managed investment product, notified foreign passport fund product or superannuation product (see cl 101C(3) of Sch 10); and
 - (d) the transaction costs for the product or option (see cl 103A(c)–(d) of Sch 10).
- RG 97.391 When a product, investment option or interposed vehicle or part was first offered in the current financial year, you must calculate the average performance fee to be disclosed by reference to your reasonable estimate of the performance fee, adjusted to reflect a 12-month period: see cl 101C(3)(d) of Sch 10.
- RG 97.392 To make a reasonable estimate, you must take reasonable steps to obtain what you believe is the best estimate of the relevant amount. Reasonable steps would include:
- (a) using reasonable assumptions when making the estimate; and

- (b) taking steps that are within your duties and obligations as a superannuation trustee, responsible entity or operator.
- RG 97.393 Whether other steps would be considered reasonable depends on:
- (a) the cost or effort involved in the step; and
- (b) how likely it is that taking the step would result in a material change to the amount that you would otherwise have estimated.
- RG 97.394 Examples of steps that you might take to obtain a reasonable estimate include:
- (a) asking an interposed vehicle for more information;
- (b) using information that has already been provided to you by an interposed vehicle;
- (c) using relevant information that you already have (e.g. information you obtained when buying or selling another asset);
- (d) researching the typical fees and costs of similar investments;
- (e) estimating the costs you would incur if you made the relevant investment instead of using a third-party provider; and
- (f) asking a service provider for further information.
- RG 97.395 We expect that you document your procedures for making reasonable estimates, including the type of information you may use when making reasonable estimates. This may help to show you have taken reasonable steps. We expect you to also make your procedures available on your website.
- RG 97.396 If there are multiple approaches you could have used to make a reasonable estimate, we expect you to include an explanation of the approach you have used in the ‘Additional explanation of fees and costs’ in your PDS.
- RG 97.397 When you estimate costs, what constitutes a reasonable estimate will often be a range. We expect you to be mindful that a low estimate brings more risk of being found later to have not been a reasonable estimate, and therefore your PDS may not be up to date. For more information on updating PDSs, see Section I at RG 97.401–RG 97.414.

Impact of tax on fees and costs disclosure in PDSs

- RG 97.398 You must not reduce the fees and costs disclosed in a PDS to take into account any tax deductions that are available to the superannuation entity, managed investment product, notified foreign passport fund product or interposed vehicle. The fact that a fee or cost may be able to be funded by a tax deduction does not affect its characterisation as a fee or cost. This means that fees and costs in a PDS must be shown gross of tax and without adjustment in relation to any tax deduction available: see cl 204(7)(a)–(c) of Sch 10.

Example

Two superannuation entities charge administration fees and costs of \$1 a week and the overall operating costs of both entities are the same (\$1 a week).

Superannuation Entity A discloses its administration fees and costs in the PDS as \$1, without reducing it by the benefit of any tax deduction that it may claim. Separately, it passes on the benefit of the tax deduction directly to the member's account.

Superannuation Entity B discloses its administration fees and costs in the PDS as \$0.85. This sum is net of the benefit of any tax deduction it may pass on to the member if it is entitled to claim a tax deduction.

Superannuation Entity B is using the benefit of the tax deduction to pay some of the administration fees and costs.

The final overall effect of the two arrangements on the member is identical because the member is, ultimately, still bearing the \$1 a week cost.

Superannuation Entity A's approach is correct and Superannuation Entity B's approach is potentially misleading because it does not disclose the true cost.

- RG 97.399 The 'Additional explanation of fees and costs' must also include information about whether the benefit of any tax deduction is passed on to the investor in the form of a reduced fee or cost: see cl 209(d) of Sch 10. For more information on the 'Additional explanation of fees and costs', see RG 97.71–RG 97.79 (for superannuation products) and RG 97.185–RG 97.190 (for managed investment products and notified foreign passport fund products).
- RG 97.400 For information on the impact of tax on fees and costs disclosed in periodic statements, see RG 97.106–RG 97.137 (for superannuation products) and RG 97.214–RG 97.239 (for managed investment products and notified foreign passport fund products).

I Updating fees and costs information

Key points

This section provides guidance on updating fees and costs information, including:

- how to update a PDS (see RG 97.401–RG 97.407); and
- updating requirements at the end of a financial year (see RG 97.408–RG 97.411) or during the financial year (see RG 97.413–RG 97.414).

It also provides guidance on significant event notices: see RG 97.415–RG 97.421.

Updating fees and costs information in PDSs

- RG 97.401 A PDS must be up to date at the time it is given: see s1012J. You can update a full PDS by issuing a supplementary PDS: see s1014A(c). You cannot update a shorter PDS by using a supplementary PDS and you must issue a new shorter PDS instead: see regs 7.9.11M and 7.9.11U.
- RG 97.402 The relief in [ASIC Corporations \(Updated Product Disclosure Statements\) Instrument 2016/1055](#) provides an alternative method you can use to update a PDS without needing to issue a supplementary PDS or, in the case of a shorter PDS, to issue a new shorter PDS.
- RG 97.403 The main requirements you must satisfy to rely on the relief in ASIC Corporations (Updated Product Disclosure Statements) Instrument 2016/1055 are that:
- (a) the PDS was up to date at the time it was prepared;
 - (b) the updated information does not include any materially adverse information (see RG 97.404);
 - (c) the PDS clearly and prominently explains that the information (other than materially adverse information) is subject to change from time to time and may be updated by means described in the PDS, and explains how the updated information can be found at any time; and
 - (d) you establish and maintain a means by which a person may find out any updated information—the means must be simple and involve no charge and little inconvenience to the person, given the kinds of people likely to consider acquiring the financial product under the PDS.
- RG 97.404 Materially adverse information is information that, if it were included in or omitted from a PDS, would render the PDS defective within the meaning of s1021B. This section sets out a number of circumstances when a PDS is

defective. These include when it contains a misleading or deceptive statement that is or would be materially adverse from the point of view of a reasonable person considering whether to proceed to acquire the financial product: see s1021B(1).

- RG 97.405 In the context of fees and costs disclosure, the assessment as to whether updated information would be materially adverse focuses on the difference between the fees and costs currently disclosed in the PDS and the fees and costs that would be disclosed in an updated PDS.
- RG 97.406 Typically, we expect that updates made in accordance with ASIC Corporations (Updated Product Disclosure Statements) Instrument 2016/1055 be made electronically on a website that investors can access.
- RG 97.407 If you update information in the ‘Fees and costs summary’, the ‘Example of annual fees and costs’ or the ‘Cost of product information’—either in a supplementary PDS or using the relief provided in ASIC Corporations (Updated Product Disclosure Statements) Instrument 2016/1055—we expect you to include a complete ‘Fees and costs summary’, an ‘Example of annual fees and costs’ and/or ‘Cost of product information’, rather than just updating particular figures. This helps consumers understand the fees and costs without having to look at two documents.

Updating requirements at the end of each financial year

- RG 97.408 Schedule 10 requires that certain costs disclosed in PDSs must be based on the costs for the previous financial year (except when the product was not offered for a full previous financial year or was only offered in the current financial year). This requirement applies to:
- (a) costs in administration fees and costs and investment fees and costs, (including indirect costs) for a superannuation product or investment option (see cl 104 of Sch 10 and RG 97.100–RG 97.102);
 - (b) costs in management fees and costs (including indirect costs) for an investment option offered by a managed investment scheme (see cl 104A of Sch 10 and RG 97.210–RG 97.213); and
 - (c) transaction costs for superannuation products, managed investment products and notified foreign passport fund products (see cl 103A of Sch 10 and RG 97.367–RG 97.369).
- RG 97.409 You will need to consider before the end of each financial year whether the costs for that financial year would change the amounts that are currently disclosed in your PDS. If they would, you may need to update your PDS to ensure that it remains up to date and is not misleading: see RG 97.401–RG 97.407.

- RG 97.410 When you are calculating the costs at the end of each financial year to determine whether you need to update your PDS, it may be necessary to make reasonable estimates of some of the costs if information about those costs is not available (e.g. the costs incurred for the last quarter of the current financial year). For information on making reasonable estimates, see RG 97.388–RG 97.397.
- RG 97.411 In addition, as performance fees for a PDS are calculated based on an average over the past five financial years (see cl 101C(3) of Sch 10), you will need to evaluate whether the performance fees incurred for that financial year would change the amount of total performance fees that are included in investment fees and costs (for superannuation products) or performance fees (for managed investment products and notified foreign passport fund products) or disclosed in the footnote to the ‘Fees and costs summary’.
- RG 97.412 If the performance fees would change the amounts currently disclosed, then you may need to update your PDS to ensure that it remains up to date and is not misleading. For more information on performance fees, see RG 97.347–RG 97.350 and RG 97.374–RG 97.387.

Updating requirements during a financial year

- RG 97.413 You must monitor changes to fees and costs during the financial year. We expect you to have policies and procedures in place to identify when you receive updated fees and costs information so that the impact of this information can be assessed.
- RG 97.414 If you become aware of changed circumstances or new information that means that a disclosed fee or cost is no longer correct, you will need to consider whether this new information means that your PDS is not up to date and therefore whether an update is required: see RG 97.401–RG 97.407. This includes when the new information shows that a previously made estimate is no longer a reasonable estimate.

Requirements for significant event notices

- RG 97.415 Section 1017B requires you to notify members of any material change to a matter, or significant event that affects a matter, being a matter that would have been required to be specified in a PDS prepared on the day before the change or event occurs. The significant event notice must give the member the information that is reasonably necessary for them to understand the nature and effect of the change or event: see s1017B(4).
- RG 97.416 A significant event notice may be given in writing or electronically: see s1017B(3). For guidance on how a significant event notice may be given electronically, see reg 7.9.75B(1), [ASIC Corporations \(Facilitating](#)

[Electronic Delivery of Financial Services Disclosure\) Instrument 2015/647](#) and [Regulatory Guide 221](#) *Facilitating digital financial services disclosure* (RG 221).

Requirements for superannuation products

- RG 97.417 Generally, members must be notified of a change that is an increase in fees or charges, or might result in an increase in fees or charges: see s1017B(5) and (7).
- RG 97.418 However, members must be notified of a change that is an increase in fees that you charge to them at least 30 days before the change takes effect: see s1017B(5).
- RG 97.419 In any other circumstances relating to fees and costs, you must notify beforehand, or as soon as practicable afterwards (but not more than three months after), any increase. In addition, you may give notice up to 12 months after the change or event if you reasonably believe that the change or event:
- (a) is not adverse to the member's interests; and
 - (b) the member would not be expected to be concerned about the delay in receiving the information (see s1017B(5) and (6)).

Requirements for managed investment products and notified foreign passport fund products

- RG 97.420 You must notify members of a change that is an increase in fees or charges, or might result in an increase in fees or charges: see s1017B(5) and (7).
- RG 97.421 Issuers of managed investment products and notified foreign passport fund products that are ED securities (as defined in s111AFA) do not have to issue significant event notices: see s1017B(2). Instead, the continuous disclosure regime in s675–677 applies.

Appendix: Interposed vehicles—Examples

RG 97.422 This appendix includes some examples of entities that would and would not be considered interposed vehicles. These examples are not intended to be an exhaustive list of possibilities, but rather practical examples of when an entity would be considered to be an interposed vehicle. For more information on the meaning of an ‘interposed vehicle’, see RG 97.300–RG 97.330.

Example 1: Investment option in Australian shares

A superannuation entity offers an investment option in Australian shares. The investment option’s exposure to Australian shares is gained by the superannuation trustee investing in an unlisted wholesale managed fund that has an investment objective of tracking the S&P/ASX 200 index.

The wholesale managed fund is an interposed vehicle on the basis of the assets test.

The person responsible for preparing the PDS for the superannuation entity has reasonable grounds to believe the wholesale managed fund has more than 70% of its assets in relevant securities—essentially, securities that are not real property or infrastructure-related securities and do not confer control: see cl 101B(1)–(2) of Sch 10.

As the wholesale managed fund holds financial products of entities, each entity in which the wholesale managed fund invests will need to be assessed against the definition of interposed vehicle.

Example 2: Registered scheme specialising in international shares

A responsible entity operates a registered scheme that is a hedge fund that the PDS discloses specialises in international shares. As part of the scheme’s strategy, the responsible entity invests in a number of other unlisted hedge funds that give negatively correlated exposure to a number of offshore markets.

The unlisted hedge funds in which the scheme invests are interposed vehicles on the basis of the PDS test.

Based on the PDS of the scheme, the unlisted hedge funds could be reasonably regarded as the *means* by which the benefit of investment in international shares is obtained, rather than the *end investment*: see cl 101B(4) of Sch 10.

Example 3: Balanced investment option

A superannuation trustee with a superannuation product offering a balanced investment option invests in a number of listed investment companies, exchange-traded funds and listed managed investment schemes. The PDS indicates that each of these vehicles provides exposure to securities,

financial products or real property that the superannuation trustee considers appropriate as part of offering a balanced investment option.

Some of these vehicles are interposed vehicles on the basis that they meet the assets test.

This is because the issuer would have reasonable grounds to believe that they have more than 70% of their assets invested in financial products: see cl 101B(1) of Sch 10.

If the investment is in a property fund and is not an interposed vehicle on the basis of the assets test, then it may still be an interposed vehicle if, based on the PDS of the superannuation product, it appears that the property fund is a *means* of investing in property rather than an *end investment*: see cl 101B(4) of Sch 10. As the PDS indicates that the investment was made to obtain exposure to real property, the property fund is a *means* by which the benefit of an investment in real property is obtained and, therefore, the property fund is an interposed vehicle.

Example 4: Cash investment option

A superannuation trustee offers a cash investment option with the objective of gaining exposure to cash investments, including term deposits and short-term money market securities. The superannuation trustee gains this exposure by investing in a life policy held with a life company that invests in the cash investments and provides an after-tax, after-fees return.

The life company is an interposed vehicle for the purpose of calculating indirect costs if the superannuation trustee has reasonable grounds to believe that it invests more than 70% of its assets in relevant securities: see cl 101B(1) of Sch 10.

However, even if the life company invested less than 70% of its assets by value in relevant securities, it is still an interposed vehicle, based on the PDS of the superannuation product. The life company could be reasonably regarded as the *means* by which the benefit from cash investments is obtained: see cl 101B(4) of Sch 10. This is because the PDS states that investment in the life policy is a cash option.

Example 5: Investment in shares of a listed public company

A superannuation trustee for a MySuper product invests in the shares of a listed public company specialising in operating mines, as part of an investment strategy of holding Australian shares. This company is not an interposed vehicle because:

- the superannuation trustee has no reasonable grounds to believe, and does not believe, based on the information the superannuation trustee has, that the company has more than 70% of its assets invested in relevant securities (its assets are predominantly mineral rights or controlling holdings in entities holding the mineral rights, not relevant securities) (see cl 101B(1) of Sch 10); and
- based on the PDS for the MySuper product, it could only be reasonably regarded as the *end investment* and not as the *means* by which exposure to mining is achieved (see cl 101B(4) of Sch 10).

Example 6: Investment option in infrastructure

A superannuation trustee discloses in the PDS an infrastructure investment option. The PDS states that it currently invests in a named unlisted trust that invests in infrastructure across Australia, and that the return of the investment option is substantially based on the investment in the trust.

This trust is an interposed vehicle under the PDS test because, based on the PDS, the investment in the unlisted trust could reasonably be regarded as a *means* to gain exposure to other assets, namely infrastructure assets, rather than being the *end investment*: see cl 101B(4) of Sch 10.

Example 7: Investment option via special purpose vehicle

A superannuation trustee discloses in the PDS that a mining company option is available for investment. The superannuation trustee uses a special purpose vehicle to hold its securities in each of the mining companies that make up the investment option.

The special purpose vehicle that holds the securities in the mining companies is an interposed vehicle because the superannuation trustee has reasonable grounds to believe that it holds more than 70% of its assets in relevant securities: see cl 101B(1) of Sch 10.

Example 8: Financial products offered through an IDPS

An IDPS operator offers investors access to a number of financial products that they may select as investments. Before they can select any of them, the IDPS operator gives each investor the PDS for the financial product and a list of the investments. In addition, the arrangement under which instructions to acquire the financial product would be acted on is a custodial arrangement, as defined in s1012IA(1).

Each of these financial products is not an interposed vehicle under the platform test. Each limb of the platform test under cl 101B(5) of Sch 10 is satisfied.

Example 9: ASX-listed AREITs

As part of an investment strategy of tracking the S&P/ASX 200 index, a superannuation trustee invests in ASX-listed AREITs, with each AREIT investing in direct property or property securities.

The AREITs are not interposed vehicles because the superannuation trustee does not believe, or have reasonable grounds to believe, that the AREITs have more than 70% of their assets in relevant securities. The AREITs may hold substantial interests in other registered schemes that are reasonably regarded as a means of investing in real property, but those interests are not relevant securities: see cl 101B(1) and (2)(a) of Sch 10.

The PDS test is not met. Based on the PDS and other information issued by the superannuation trustee, the interests in the AREIT must be regarded as the *end investment* and not the *means* by which the *end investment* in property is obtained.

Note: An AREIT may be an interposed vehicle in other circumstances.

Example 10: Pooled superannuation trust

A PDS for a superannuation entity explains that the entity offers exposure to a high-growth equities portfolio and that the superannuation trustee gains this exposure by investing in a pooled superannuation trust.

The pooled superannuation trust is an interposed vehicle under the assets test because it invests more than 70% of its assets in relevant securities: see cl 101B(1) of Sch 10.

Even if the pooled superannuation trust is not an interposed vehicle based on the assets test, it will be an interposed vehicle based on the PDS test. Based on the PDS and other information issued by the superannuation trustee, the pooled superannuation trust should be reasonably regarded as the means by which the benefit of the investment is obtained rather than being the end investment: see cl 101B(4) of Sch 10.

Key terms

Term	Meaning in this document
accessible financial product	A financial product acquired pursuant to an instruction under a custodial arrangement, as defined in s1012IA of the Corporations Act
Additional explanation of fees and costs	The information required under cl 209 of Sch 10 to the Corporations Regulations
advice fee	Has the meaning given in cl 101 of Sch 10
AREIT	Australian real estate investment trust
assets test	The test for determining whether an entity is an interposed vehicle based on the assets of the entity: see cl 101B(1)–(3) of Sch 10 and RG 97.311–RG 97.316
Australian passport fund	A registered scheme that is also registered as a passport fund under Pt 8A.3 of the Corporations Act
balanced investment option	An investment option in which the ratio of investment in growth assets, such as shares or property, to the investment in defensive assets, such as cash or bonds, is as close as practicable to 70:30: see cl 101 of Sch 10, as incorporated by cl 7(5) of Sch 10D and cl 7(4) of Sch 10E
borrowing costs	Has the meaning given in cl 101 of Sch 10
buy–sell spread	Has the meaning given in cl 101 of Sch 10
certain types of physical infrastructure	The types of physical infrastructure defined in cl 101B(6)(a)–(k) of Sch 10
[CO 14/1252] (for example)	An ASIC class order (in this example numbered 14/1252) Note: Legislative instruments made from 2015 are referred to as ASIC instruments.
collective investment product	Has the meaning given in cl 101 of Sch 10

Term	Meaning in this document
conflicted remuneration	<p>A benefit given to an Australian financial services (AFS) licensee, or a representative of a licensee, who provides financial product advice to clients that, because of the nature of the benefit or the circumstances in which it is given, could reasonably be expected to influence:</p> <ul style="list-style-type: none"> the choice of financial product recommended to clients by the licensee or its representative; or the financial product advice given to clients by the licensee or its representative. <p>In addition, the benefit must not be excluded from being conflicted remuneration by the Corporations Act or Corporations Regulations</p>
Consumer advisory warning	The consumer advisory warning required by Div 7 of Pt 2 of Sch 10
Corporations Act	<i>Corporations Act 2001</i> , including regulations made for the purposes of that Act
Corporations Regulations	<i>Corporations Regulations 2001</i>
Cost of product information	The 'Cost of product information' required by Div 6A of Pt 2 of Sch 10
CP 308 (for example)	An ASIC consultation paper (in this example numbered 308)
defined benefit member	A superannuation entity member who is entitled to benefits defined solely by reference to the factors in paragraphs (a) and/or (b) of the definition of 'defined benefit member' in reg 1.03(1) of the SIS Regulations
defined benefit superannuation entity	Has the same meaning as 'defined benefit fund' in reg 1.03(1) of the SIS Regulations
derivative financial product	<p>Either an OTC derivative or a security or managed investment product that embeds a derivative</p> <p>Note: The exact definition is in cl 101(3A) of Sch 10.</p>
Div 6 (for example)	A division of the Corporations Act (in this example numbered 6), unless otherwise specified
entity	A body, trust or partnership
Example of annual fees and costs	The example of annual fees and costs required by Div 5 of Pt 2 of Sch 10
excluded transactional and operational costs	Has the meaning given in cl 103(2) of Sch 10

Term	Meaning in this document
fees and costs disclosure requirements	The requirements relating to fees and costs set out in the Corporations Act and in the Corporations Regulations (including Schs 10, 10D and 10E to the Corporations Regulations)
Fees and costs summary	The fees and costs summary set out in Divs 1 and 2 of Pt 2 of Sch 10
financial market	Has the meaning given in s767A of the Corporations Act, and includes a facility through which offers to acquire or dispose of financial products are regularly made or accepted
financial product	<p>A facility through which, or through the acquisition of which, a person does one or more of the following:</p> <ul style="list-style-type: none"> • makes a financial investment (see s763B); • manages financial risk (see s763C); <ul style="list-style-type: none"> • makes non-cash payments (see s763D). <p>Note: This definition is contained in s763A of the Corporations Act: see also s763B–765A.</p>
financial product advice	<p>A recommendation or a statement of opinion, or a report of either of these things, that:</p> <ul style="list-style-type: none"> • is intended to influence a person or persons in making a decision about a particular financial product or class of financial product, or an interest in a particular financial product or class of financial product; or • could reasonably be regarded as being intended to have such an influence. <p>This does not include anything in an exempt document or statement</p> <p>Note: This definition is contained in s766B of the Corporations Act.</p>
GST	Goods and services tax
IDPS	An investor directed portfolio service as defined in Class Order [CO 13/763] <i>Investor directed portfolio services</i> or any instrument that amends or replaces that class order
IDPS Guide	A document provided by an IDPS operator instead of a PDS to help retail clients decide whether they should use the IDPS
IDPS-like scheme	An investor-directed-portfolio-service-like scheme as defined in Class Order [CO 13/762] <i>Investor directed portfolio services provided through a registered managed investment scheme</i> , or any instrument that amends or replaces that class order
implicit transaction costs or market impact costs	Cost impacts that are generally not objectively observable that are usually embedded in the price paid for an asset. These costs can include bid–ask spreads and implementation shortfall (the difference in price between the decision to trade and the execution of the trade)

Term	Meaning in this document
incorporated by reference	Information available in a document other than a PDS but incorporated by reference into a shorter PDS in accordance with regs 7.9.11P and 7.9.11X, or into a full PDS in accordance with reg 7.9.15DA
indirect cost	Has the meaning given in cl 101A of Sch 10
infrastructure entity	Has the meaning given in cl 101B(6) of Sch 10
interposed vehicle	The investment vehicle through which a superannuation entity or managed investment scheme might directly or indirectly invest to obtain access to the underlying product or asset Note: See cl 101B of Sch 10 for the exact definition.
intrafund advice costs	Costs incurred by a superannuation trustee (other than costs incurred as advice fees) in making available to all members investing in a particular MySuper product or investment option, and providing to one or more member, financial product advice by the superannuation trustee or another person acting as an employee of or under an arrangement with the trustee: see cl 101 of Sch 10
issuer	The person who makes the relevant superannuation product, managed investment product or notified foreign passport fund product available. For a superannuation product, this is a superannuation trustee. For an interest in a registered scheme, this is the responsible entity. For an interest in a notified foreign passport fund, this is the operator of the fund
managed investment product	An interest in a registered scheme, a legal or equitable right in such an interest, or an option to acquire by way of issue such an interest or right, as defined in 764A(1)(b) of the Corporations Act
managed investment scheme	Has the meaning given in s9 of the Corporations Act
MDA	A managed discretionary account
MDA service	Some or all of the services and functions involved in providing an MDA
member	A member of a superannuation entity, managed investment scheme or notified foreign passport fund, including a prospective member
MySuper product	A default superannuation product provided under Pt 2C of the SIS Act
notified foreign passport fund	Has the meaning given in s1213C of the Corporations Act

Term	Meaning in this document
notified foreign passport fund product	An interest in a notified foreign passport fund, a legal or equitable right in such an interest, or an option to acquire by way of issue such an interest or right, as defined in s764A(1)(bb) of the Corporations Act
OTC	Over the counter
PDS	A Product Disclosure Statement—a document that must be given to a retail client for the offer or issue of a financial product, in accordance with Div 2 of Pt 7.9 of the Corporations Act Note: See s761A for the exact definition.
PDS test	The test for determining whether an entity is an interposed vehicle based on whether the entity could reasonably be regarded as the means by which the benefit of an investment is obtained rather than the end investment: see cl 101B(4)–(4D) of Sch 10 and RG 97.317–RG 97.324
performance fee	Has the meaning given in cl 101C(1) of Sch 10
periodic statement	A statement required to be sent to certain persons who acquired financial products as a retail client under s1017D on at least an annual basis while holding the product (ongoing) and on ceasing to hold the financial product (exit)
personal advice	Financial product advice given or directed to a person (including by electronic means) in circumstances where: <ul style="list-style-type: none"> the person giving the advice has considered one or more of the person's objectives, financial situation and needs; or a reasonable person might expect the person giving the advice to have considered one or more of these matters Note: This definition is contained in s766B(3) of the Corporations Act.
platform	A superannuation platform, an IDPS-like scheme or an IDPS
platform operator	The superannuation trustee of a superannuation platform, the responsible entity of an IDPS-like scheme or the IDPS operator of an IDPS
platform test	The test for determining whether an entity is an interposed vehicle on the basis that it is an investment obtained through a custodial arrangement: see cl 101B(5) of Sch 10 and RG 97.307–RG 97.309
property operating costs	Has the meaning given in cl 101 of Sch 10
Pt 7.9 (for example)	A part of the Corporations Act (in this example numbered 7.9), unless otherwise specified
reg 7.9.16N (for example)	A regulation of the Corporations Regulations (in this example numbered 7.9.16N), unless otherwise specified

Term	Meaning in this document
registered scheme	A managed investment scheme that is registered under s601EB of the Corporations Act
relevant securities	Securities that are not real property or infrastructure-related securities and do not confer control
responsible entity	A responsible entity of a registered scheme, as defined in s9 of the Corporations Act
retail client	A client as defined in s761G of the Corporations Act and Div 2 of Pt 7.1 of the Corporations Regulations
RG 179 (for example)	An ASIC regulatory guide (in this example numbered 179)
s1013C (for example)	A section of the Corporations Act (in this example numbered 1013C), unless otherwise specified
Sch 10 (for example)	A schedule to the Corporations Regulations (in this example numbered 10), unless otherwise specified
shorter PDS	A PDS that is required to comply with the shorter PDS regime
shorter PDS regime	The requirements set out in Div 3A of Pt 7.9 of the Corporations Act as modified by Subdivs 4.2B–4.2C and Schs 10D and 10E to the Corporations Regulations, which prescribe the content and length of the PDS for certain superannuation products and simple managed investment schemes
simple managed investment scheme	A registered scheme that invests at least 80% of its assets in a bank account where funds can be withdrawn within three months, or in arrangements where the responsible entity can reasonably expect to realise the investment at market value within 10 days: see reg 1.0.2 of the Corporations Regulations
SIS Act	<i>Superannuation Industry (Supervision) Act 1993</i>
SIS Regulations	Superannuation Industry (Supervision) Regulations 1994
SMSF	A self-managed superannuation fund
superannuation entity	Has the meaning given in s10(1) of the SIS Act
superannuation platform	A superannuation entity that offers a choice of investment strategies to members where accessible financial products will be acquired under the member's choice of investment strategy
superannuation product	A superannuation interest within the meaning of the SIS Act: see s764A(1)(g)
superannuation trustee	A person or group of persons licensed by the Australian Prudential Regulation Authority (APRA) under s29D of the SIS Act to operate a registrable superannuation entity (e.g. superannuation fund) (also known as an 'RSE licensee')

Term	Meaning in this document
transaction costs	Has the meaning given in cl 103 of Sch 10
transitional version of RG 97	The version of RG 97 released in March 2017, which will continue to apply until the commencement of ASIC Corporations (Disclosure of Fees and Costs) Instrument 2019/1070
ultimate reference asset	The financial product (which includes securities) or other asset or assets from which the returns from the derivative financial product are ultimately determined Note: See cl 101A(3A) of Sch 10 for the exact definition.

Related information

Headnotes

costs, fees, fees and costs disclosure requirements, IDPS, indirect costs, insurance products, interposed vehicle, managed investment products, notified foreign passport fund products, management fees and costs, MDA services, PDSs, operators of notified foreign passport funds, performance fee, periodic statements, platform operators, Product Disclosure Statements, responsible entities, shorter PDS regime, simple managed investment scheme, superannuation products, superannuation trustees, transaction costs

Legislative instruments

[\[CO 12/749\]](#) *Relief from the shorter PDS regime*

[\[CO 13/762\]](#) *Investor directed portfolio services provided through a registered managed investment scheme*

[\[CO 13/763\]](#) *Investor directed portfolio services*

[\[CO 13/1200\]](#) *Periodic statements relief for AQUA quoted and listed managed investment scheme manager*

[\[CO 14/1252\]](#) *Technical modifications to Schedule 10 of the Corporations Regulations*

[ASIC Corporations \(Facilitating Electronic Delivery of Financial Services Disclosure\) Instrument 2015/647](#)

[ASIC Corporations \(Superannuation: Investment Strategies\) Instrument 2016/65](#)

[ASIC Corporations \(Disclosure in Dollars\) Instrument 2016/767](#)

[ASIC Corporations \(Managed Discretionary Account Services\) Instrument 2016/968](#)

[ASIC Corporations \(Updated Product Disclosure Statements\) Instrument 2016/1055](#)

[ASIC Corporations \(Disclosure of Fees and Costs\) Instrument 2019/1070](#)

Regulatory guides

[RG 45](#) *Mortgage schemes: Improving disclosure for retail investors*

[RG 94](#) *Unit pricing: Guide to good practice*

[RG 148](#) *Platforms that are managed investment schemes and nominee and custody services*

[RG 168](#) *Disclosure: Product Disclosure Statements (and other disclosure obligations)*

[RG 179](#) *Managed discretionary accounts*

[RG 182](#) *Dollar disclosure*

[RG 184](#) *Superannuation: Delivery of product disclosure for investment strategies*

[RG 221](#) *Facilitating digital financial services disclosure*

[RG 240](#) *Hedge funds: Improving disclosure*

Consultation papers

[CP 308](#) *Review of RG 97 Disclosing fees and costs in PDSs and periodic statements*

Information sheets

[INFO 133](#) *Shorter PDS regime: Superannuation managed investment schemes and margin lending*

[INFO 155](#) *Shorter PDSs: Complying with requirements for superannuation products and simple managed investment schemes*

Legislation

Corporations Act, Pt 7.9, Divs 2 and Div 3A, Pt 8A.3; s9, 601EB, 601FC(1)(c), 675, 676, 677, 761A, 761G, 761G(1), 761G(5), 761G(6), 761G(7), 761GA, 763A, 763B, 763C, 763D, 764A, 764A(1)(g), 765A, 766B, 766B(3), 767A, 912AD, 912AD(5)(e), 912AEA, 1012IA(1), 1012J, 1013C(3), 1014A(c), 1017B, 1017B(2), 1017B(4), 1017B(5), 1017B(6), 1017B(7), 1017D, 1017D(2), 1017D(3), 1017D(3A), 1017D(3AA), 1017D(3AB), 1017D(4), 1017D(5), 1017D(5)(c), 1017DA, 1020E, 1021B, 1021B(1)

Corporations Regulations, Pt 7.1, Div 2, Pt 7.9, Subdivs 4.2B, 4.2C, 4.2C.3, 5.2, 5AA and 8; regs 1.0.02, 7.9.11K, 7.9.11M, 7.9.11O(2), 7.9.11P, 7.9.11S, 7.9.11S(4), 7.9.11U, 7.9.11W(2), 7.9.11X, 7.9.15DA, 7.9.16N, 7.9.16N(2)(a), 7.9.16N(2)(b), 7.9.16N(2)(c), 7.9.16O, 7.9.19(g), 7.9.20(1)(a), 7.9.20(1)(b), 7.9.20(1)(d), 7.9.20(1)(kb), 7.9.60B(2), 7.9.60B(3), 7.9.60B(5), 7.9.60B(6), 7.9.60B(7), 7.9.75(1)(a), 7.9.75(1)(b), 7.9.75(1)(e), 7.9.75(2), 7.9.75B(1); Schs 10, 10A, 10D and 10E

SIS Act, s10(1), 29D, 52(2)(b), 52(2)(c), 62

SIS Regulations, regs 1.03(1), 1.06(2), 1.06(6), 1.06(7)

Cases

George v Rockett (1990) 170 CLR 104

Reports

[REP 398](#) *Fees and cost disclosure: Superannuation and managed investment products*

[REP 581](#) *Review of ASIC Regulatory Guide 97: Disclosing fees and costs in PDSs and periodic statements*

[REP 637](#) *Response to submissions on CP 308 Review of Regulatory Guide 97*

[REP 638](#) *Consumer testing of the fees and costs tools for superannuation and managed investment schemes*

Media and other releases

[14-158MR](#) *ASIC reports on fee disclosure practices for super and managed investments* (8 July 2014)

[17-369MR](#) *ASIC updates work on fee transparency for super and managed investment schemes* (1 November 2017)

[17-409MR](#) *ASIC appoints expert to review fees and costs disclosure settings* (28 November 2017)

[18-217MR](#) *External report on fees and costs disclosure welcomed by ASIC* (24 July 2018)

[18-372MR](#) *ASIC extends transition period for some fees and costs disclosures* (11 December 2018)

[19-149MR](#) *ASIC amends fees and costs disclosure to align with Protecting Your Super Package laws* (21 June 2019)